

*ski-doo*



# OPERATOR'S GUIDE

Includes Safety, Use and Maintenance Information

2025

## WARNING

Read this guide thoroughly. It contains important safety information.

Minimum recommended operators age: 16 years old.  
Keep this operator's guide with the vehicle at all times.

**ELECTRIC SERIES**  
Original Instructions

**WARNING**

**Operating, servicing and maintaining an off-road vehicle can expose you to chemicals including engine exhaust, carbon monoxide, phthalates, and lead, which are known to the State of California to cause cancer and birth defects or other reproductive harm. To minimize exposure, avoid breathing exhaust, do not idle the engine except as necessary, service your vehicle in a well-ventilated area and wear gloves or wash your hands frequently when servicing your vehicle. For more information go to [www.p65warnings.ca.gov/products/passenger-vehicle](http://www.p65warnings.ca.gov/products/passenger-vehicle).**

**CALIFORNIA PROPOSITION 65 WARNING****WARNING**

**Battery posts, terminals and related accessories contain lead and lead compounds, which are known to the State of California to cause cancer and birth defects or other reproductive harm. To minimize exposure, wear gloves or wash your hands frequently when servicing your vehicle. For more information, go to [www.P65Warnings.ca.gov](http://www.P65Warnings.ca.gov)**

Deutsch	Dieses Handbuch ist möglicherweise in Ihrer Landessprache verfügbar. Bitte wenden Sie sich an Ihren Händler oder besuchen Sie: <a href="http://www.operatorsguides.brp.com">www.operatorsguides.brp.com</a>
English	This guide may be available in your language. Check with your dealer or go to: <a href="http://www.operatorsguides.brp.com">www.operatorsguides.brp.com</a>
Español	Es posible que este manual esté disponible en su idioma. Consulte a su distribuidor o visite: <a href="http://www.operatorsguides.brp.com">www.operatorsguides.brp.com</a>
Français	Ce guide peut être disponible dans votre langue. Vérifier avec votre concessionnaire ou aller à: <a href="http://www.operatorsguides.brp.com">www.operatorsguides.brp.com</a>
Italiano	Questa guida potrebbe essere disponibile nella propria lingua. Contattare il concessionario o consultare: <a href="http://www.operatorsguides.brp.com">www.operatorsguides.brp.com</a>
中文	本手册可能有您的语种的翻译版本。请向经销商询问，或者登录 <a href="http://www.operatorsguides.brp.com">www.operatorsguides.brp.com</a> 查询。
日本語	このガイドは、言語によって翻訳版が用意されています。ディーラーに問い合わせるか、次のアドレスでご確認ください： <a href="http://www.operatorsguides.brp.com">www.operatorsguides.brp.com</a>
Nederlands	Deze handleiding kan beschikbaar zijn in uw taal. Vraag het aan uw dealer of ga naar: <a href="http://www.operatorsguides.brp.com">www.operatorsguides.brp.com</a>
Norsk	Denne boken kan finnes tilgjengelig på ditt eget språk. Kontakt din forhandler eller gå til: <a href="http://www.operatorsguides.brp.com">www.operatorsguides.brp.com</a>
Português	Este manual pode estar disponível em seu idioma. Fale com sua concessionária ou visite o site: <a href="http://www.operatorsguides.brp.com">www.operatorsguides.brp.com</a>
Русский	Воспользуйтесь руководством на вашем языке. Узнайте о его наличии у дилера или на странице по адресу <a href="http://www.operatorsguides.brp.com">www.operatorsguides.brp.com</a>
Suomi	Käyttöohjekirja voi olla saatavissa omalla kielelläsi. Tarkista jälleenmyyjältä tai käy osoitteessa: <a href="http://www.operatorsguides.brp.com">www.operatorsguides.brp.com</a>
Svenska	Denna bok kan finnas tillgänglig på ditt språk. Kontakta din återförsäljare eller gå till: <a href="http://www.operatorsguides.brp.com">www.operatorsguides.brp.com</a>

---

<b>Model</b>	<b>Track length</b>
<b>Grand Touring Electric</b>	<b>3048 mm(120 in.)</b>
<b>Expedition Electric</b>	<b>3487 mm(137 in.)</b>

---



# TABLE OF CONTENTS

---

GENERAL INFORMATION	1
SAFETY INFORMATION	2
ELECTRIC VEHICLE (EV) OVERVIEW	3
VEHICLE INFORMATION	4
MAINTENANCE	5
TECHNICAL INFORMATION	6
TECHNICAL SPECIFICATIONS	7
TROUBLESHOOTING	8
WARRANTY	9
CUSTOMER INFORMATION	10

---



# 1 GENERAL INFORMATION - TABLE OF CONTENTS

---

<b>GENERAL INFORMATION</b> . . . . .	<b>1-2</b>
Know Before You Go . . . . .	1-3
Safety Messages . . . . .	1-3
About this Operator's Guide . . . . .	1-4
Respect of the Environment . . . . .	1-6

---

## **GENERAL INFORMATION**

Congratulations on your purchase of a new BRP snowmobile. Whatever model you have chosen, it is backed by the Bombardier Recreational Products Inc. (BRP) warranty and a network of authorized BRP snowmobile dealers ready to provide the parts, service or accessories you may require.

Your dealer is committed to your satisfaction. He has taken training to perform the initial set-up and inspection of your snowmobile as well as completed the final adjustment required to suit your specific weight and riding environment before you took possession.

At delivery, you were informed of the warranty coverage and signed the Pre-delivery Check List to ensure your new vehicle was prepared to your entire satisfaction.



### Know Before You Go

To learn how to reduce the risk for you, your passenger or bystanders being injured or killed, read the following sections before you operate the vehicle:

- *Safety Information*
- *Vehicle Information*
- *Electric Vehicle Overview*

### Safety Messages

This operator's guide utilizes the following symbols and words to emphasize particular information:

 This is the safety alert symbol. It is used to alert you to potential physical injury hazards. Obey all safety messages that follow this symbol to avoid possible injury or death.

Also read all safety labels on your snowmobile and watch attentively the safety video located at:

[www.ski-doo.com/safety](http://www.ski-doo.com/safety).

Or, use the following QR code.





Indicates a potential hazard which if not avoided, will result in serious injury or death.



Indicates a potential hazard which, if not avoided, could result in serious injury or death.



Indicates a hazard situation which, if not avoided, could result in minor or moderate injury.

*NOTICE*

Indicates installation, operation, or maintenance information which is important but not hazard-related. In some cases, if not followed, vehicle components or other properties could be severely damaged.

## About this Operator's Guide

This operator's guide has been prepared to acquaint the owner, operator and passenger with this snowmobile and its various controls, maintenance and safe riding instructions.

The following terminology in regards to operator, passenger and vehicle configuration is used as follows throughout this guide:

- **Operator:** refers to the person being behind the controls and driving the snowmobile.
- **Passenger:** refers to a person sitting behind the operator.
- **1-UP:** refers to a model designed for an operator only.
- **2-UP:** refers to a model designed to accommodate **one** passenger.

Keep this operator's guide in the vehicle at all times, either in the glove box or its water-tight designated location, as you can refer to it for operation, instructing others, maintenance and troubleshooting.

Note that this guide is available in several languages. In the event of any discrepancy, the English version shall prevail.

If you want to view and/or print an extra copy of your operator's guide, simply visit the following website:

**[www.operatorsguides.brp.com](http://www.operatorsguides.brp.com)**

---

The information contained in this document is correct at the time of publication. BRP, however, maintains a policy of continuous improvement of its products without imposing upon itself any obligation to install them on products previously manufactured. Due to late changes, some differences between the manufactured product and the descriptions and/or specifications in this guide may occur. BRP reserves the right at any time to discontinue or change specifications, designs, features, models or equipment without incurring any obligation upon itself.

This operator's guide should remain with the vehicle when it's sold and transferred to the new owner at the time of sale.

## **Respect of the Environment**

The guidelines that we support are not designed to limit your snowmobiling fun, but to preserve the beautiful freedom that you can experience only on a snowmobile! These guidelines will keep snowmobilers healthy, happy and able to introduce others to what they know and enjoy about their favorite winter pastime. So, the next time you hit the trails on a cool, crisp and clear winter day, we ask you to remember that you are paving the way for the future of our sport. Help us lead it down the right path! From all of us at BRP, thank you for doing your share.

There is nothing more exhilarating than snowmobiling. Venturing onto snowmobile trails that cross wild areas is an exciting and healthy winter sport. However, as the number of people using these recreational parks increases, so does the potential for damage to the environment. Abuse of land, facilities and resources inevitably leads to restrictions and closures of both private and public land.

In essence, the greatest threat to our sport is all around us. Which leaves us with one logical choice. When we snowmobile, we must always ride responsibly.

The vast majority respect the law and the environment. Each of us must set an example for those who are new to the sport, young and old alike.

It is in everyone's best interest to tread lightly into our recreational areas. Because, in the long run, to protect the sport we must preserve the environment.

Recognizing the importance of this issue and the need for snowmobilers to do their share in preserving areas that make it possible to enjoy our sport, BRP has developed the "Light Treading Is Smart Sledding" campaign for snowmobilers.

Light Treading refers to more than the thread of our tracks. It's a statement of concern, respect and willingness to take the lead and take action. It applies to the environment in general, its proper care and maintenance, its natural inhabitants and all enthusiasts and the public at large who enjoy the great outdoors. With this theme, we invite all snowmobilers to remember that respecting the environment is not only critical to the future of our industry, but to future generations.

Light Treading in no way suggests you should curb your appetite for snowmobiling fun! It simply means tread with respect!

The fundamental objective of Light Treading is one of respect for where and how you ride a snowmobile. You're a light treader when you follow the principles below.

---

**Become informed.** Obtain maps, regulations and other information from the Forest Service or from other public land agencies. Learn the rules and follow them – and that goes for speed limits, too!

**Avoid** running over young trees, shrubs, and grasses, and don't cut wood. On flatlands or areas where trail riding is popular, it's important to ride only where authorized. Remember, there is a link between protecting your environment and your own safety.

**Respect wildlife** and be particularly sensitive of animals that are rearing young or suffering from food shortage. Stress can sap scarce energy reserves. Refrain from riding in areas where only animals are intended to tread!

**Obey** gate closures and regulatory signs and remember, light treaders don't litter!

**Stay out** of wilderness areas. They're closed to all vehicles. Know where the boundaries are.

**Obtain permission** to travel across private land. Respect the rights of landowners and other people's privacy. Remember, snowmobile technology has lowered the noise factor considerably, and electric snowmobiles are even quieter, but you still should be mindful where quiet "is the order of the day."

Snowmobilers know all too well the efforts that have been made throughout the sport's history to enjoy access to areas where people can snowmobile safely and responsibly. This effort continues today, as strong as ever.

Respecting the areas where we ride, wherever they may be, is the only way to ensure their future enjoyment. That's one major reason why we know you'll agree that Light Treading is Smart Sledding! And there are more.

Enjoying the opportunity to see winter and all its natural majestic wonders is an experience cherished by snowmobilers. Light Treading will preserve this opportunity and make it possible for us to expose others to the beauty of winter and the unique thrill of our sport! Light Treading will help our sport to grow!

Finally, Light Treading is the sign of a smart snowmobiler. You don't have to leave big tracks or careen through a virgin forest to show you can ride. So whether you're driving a high performance BRP snowmobile or any other make or model, show you know what you're doing. Show you know how to send snow flying and make tracks with a light touch!





## 2 SAFETY INFORMATION - TABLE OF CONTENTS

### **BEFORE YOU GO . . . . .2-3**

Operating Age and Ability . . . . .	2-3
Drugs and Alcohol . . . . .	2-4
Avalanche Safety Training Courses . . . . .	2-4
Protective Gear . . . . .	2-4
Required Equipment . . . . .	2-5
Emergency Response . . . . .	2-5
Hazardous Materials . . . . .	2-6

### **GET FAMILIAR WITH THE SNOWMOBILE . . . . .2-7**

Track Propulsion System . . . . .	2-7
Steering . . . . .	2-8
Tether Cord . . . . .	2-9
Braking . . . . .	2-9
Parking Brake . . . . .	2-9
Programmable D.E.S.S. Key . . . . .	2-10
Carrying Loads . . . . .	2-10

Towing Loads . . . . .	2-11
Towing Another Snowmobile . . . . .	2-12
Accessories and Modifications . . . . .	2-14
Unauthorized Modifications . . . . .	2-15

### **RIDE SAFELY . . . . . 2-16**

Rider Position (Forward Operation) . . . . .	2-16
Rider Position (Reverse Operation) . . . . .	2-19
Riding with Passenger(s) . . . . .	2-19
Riding Alone . . . . .	2-20
Riding in a Group . . . . .	2-21
Avoiding Collisions . . . . .	2-22
Riding Behaviors . . . . .	2-23
Speeding . . . . .	2-23
Moving Parts . . . . .	2-23
Know Terrain and Riding Variations . . . . .	2-24
Respect of the Wildlife . . . . .	2-31

### **PRACTICE EXERCISES . . . . . 2-32**

## **2 SAFETY INFORMATION - TABLE OF CONTENTS**

---

Where to Practice Exercises . . . . .	2-32
Exercises to Practice . . . . .	2-32
<b>TRANSPORTING THE VEHICLE . . . . .</b>	<b>2-36</b>
Pushing or Pulling the Vehicle . . . . .	2-38
<b>IMPORTANT ON-PRODUCT LABELS (CANADA/UNITED STATES) . . . . .</b>	<b>2-41</b>
Vehicle Safety Labels . . . . .	2-41
<b>REPORTING SAFETY DEFECTS . . . . .</b>	<b>2-61</b>
<b>PRE-RIDE INSPECTION . . . . .</b>	<b>2-62</b>
Before Starting . . . . .	2-62
After Starting . . . . .	2-62
Pre-Ride Check List . . . . .	2-63

## BEFORE YOU GO



Disregarding any of the safety precautions and instructions contained in this section could cause injury including the possibility of death.

### Operating Age and Ability

Operators must be qualified. Make sure the operator is 16 or older. Your state (or province) may have additional requirements. Laws regarding the minimum age and licensing requirements vary from one jurisdiction to another. Be sure to contact the local authorities for information regarding the legal operation of a snowmobile in the intended jurisdiction of use. BRP highly recommends that you take a safety riding course. Basic training is required for the safe operation of any snowmobile.

Operation of this snowmobile with a disability that impairs vision, reaction time, judgment, or operation of the controls is not recommended. The safe use of your snowmobile depends on many conditions such as visibility, speed, weather, environment, traffic, vehicle condition and the condition of the operator. The performance of some snowmobiles may significantly exceed that of other snowmobiles you have operated. Therefore, use by novice or inexperienced operators is not recommended.

Each passenger must be able to simultaneously place both feet firmly flat against each footboard when properly seated.

---

## Drugs and Alcohol

Never ride after consuming alcohol or drugs. Riding on a snowmobile requires the operator and passenger to be sober, attentive and alert. The use of drugs and alcohol, singly or in combination, increases reaction time, impedes judgment, impairs vision and inhibits your ability to safely ride on a snowmobile.

## Avalanche Safety Training Courses

We recommend that all mountain riders take a local avalanche safety training course to become more familiar with snow conditions and learn how to properly use their equipment. Here are some websites that can help you find important information:

- – US: [www.avalanche.org](http://www.avalanche.org)
- – Europe: [www.avalanches.org](http://www.avalanches.org)
- – Canada: [www.avalanche.ca](http://www.avalanche.ca)

## Protective Gear

Proper snowmobile clothing should be worn by all riders. It should be comfortable and not too tight. Always check the weather forecast before going on a ride. Dress for the coldest weather expected. Thermal underwear next to the skin also provides a good insulation.

Always wear an approved helmet at all times for safety and comfort. They provide warmth and reduce injury. A stocking type cap, balaclava and face mask should always be carried or worn. Goggles or a face shield that attach to the helmet are indispensable.

Hands should be protected by a pair of snowmobile gloves or mitts which have sufficient insulation and allow use of thumbs and fingers for operation of controls.

Wear boots designed for snowmobiling.

You should keep yourself as dry as possible when snowmobiling. When you come indoors, take your snowmobile suit and boots off and make certain they dry properly.

Do not wear a long scarf or loose apparels that could get caught in moving parts.

Carry colored lens goggles.

### Required Equipment

As the owner of the snowmobile, you are responsible for ensuring that all required safety equipment is aboard. Check your local regulations about requirements.

First aid kit	Provided tool kit
Cell phone	Knife
Flashlight	Adhesive tape (duct tape)

Trail map	Snack
Probe*	Shovel*
Avalanche beacon*	
*When riding in an area with avalanche risk	

### Emergency Response

BRP electric snowmobiles are equipped with safety features for your protection. In the event of an incident, accident or submersion in water additional precautions are required to protect yourself from the high-voltage hazards.

If this occurs, stop using the vehicle. The vehicle should be inspected by a BRP dealer prior to next ride. Contact local emergency service for immediate assistance.



**DANGER**

The lithium-ion high-voltage propulsion battery or high-voltage components can cause electrical shock and/or fire when damaged. Do not disconnect or touch any exposed connections and/or damaged components with bare fingers, non-insulated tools or other metallic objects. Contact with high-voltage current will cause severe injury or death.

A damaged lithium-ion high-voltage battery can leak electrolyte and/or generate flammable gas. Contact with electrolyte will cause severe injury, rinse the affected area with water and seek for immediate medical attention.

The vehicle high-voltage system must be disabled using the First Responder Cut Loop (FRCL) located under the left side body panel. The FRCL usage is reserved to the emergency personnel or first responder only. The electric snowmobile should only be lifted or manipulated by personnel properly trained, equipped and advised that the vehicle presents high-voltage hazards.

Additional information can be found in the vehicle's *Emergency Response Guide* available at this address:

- <https://operatorsguides.brp.com/>

## Hazardous Materials

Lithium-ion high-voltage propulsion batteries are considered hazardous materials. Special care are required for BRP electric vehicles or high-voltage propulsion batteries disposal. Refer to local regulations regarding shipping or recycling requirement for hazardous materials. Contact an authorized BRP dealer for additional information.

### GET FAMILIAR WITH THE SNOWMOBILE

This vehicle may exceed the performance of other vehicles you may have ridden. Take time to familiarize yourself with your new vehicle.

Inexperienced riders may overlook risks and be surprised by the vehicle's specific behavior and terrain conditions. Ride slowly. Excessive speed and reckless driving can kill.

Make sure you read and understand the content of this operator's guide to become completely familiar with the controls and operation of the snowmobile before embarking on your first trip or taking on a passenger. If you have not had the opportunity to do so, practice driving solo in a suitable traffic-free area to become accustomed to the feel and response of each control.

It is very important to inform any operator, regardless of his experience, of the handling characteristics of this snowmobile. The snowmobile configuration, such as ski stance, ski type, suspension type, track length, width and type vary from one model to another. The snowmobile handling is greatly influenced by these characteristics.

### Track Propulsion System

Your snowmobile features a track propulsion system. The track grips on the snow-covered surface and pushes the snowmobile in the opposite direction of the force applied on the surface. Stay away from the track. Personal injury will result if contact is made with the revolving track.



Never stand behind or near a rotating track. Debris could be projected causing severe injuries.

---

The grip of the track will vary depending on the surface conditions. The grip may be reduced on hard-pack snow or ice. Reduce your speed and allow more space to turn. Refer to the *SNOWMOBILES EQUIPPED WITH TRACTION ENHANCING PRODUCTS* subsection of this guide to learn how to balance the grip of the ski vs the grip of the track. If the front and rear of the snowmobile are out of balance due to an incorrect combination of traction enhancing products, the snowmobile may tend to oversteer or understeer, which could lead to a loss of control.

## Steering

Skis are used to steer the snowmobile with the handlebar. The performance to steer will vary depending on the grip of the skis on the surface. Steering control ability may be reduced on hard-pack snow, ice or roads. Reduce speed and allow more space to turn. Refer to the *SNOWMOBILES EQUIPPED WITH TRACTION ENHANCING PRODUCTS* subsection of this guide to learn how to balance the grip of the ski versus the grip of the track. If the front and rear of the snowmobile are out of balance due to an incorrect combination of traction enhancing products, the snowmobile may tend to oversteer or understeer, which could lead to a loss of control.

When riding with a passenger or carrying loads, the steering control will also be reduced. Reduce speed and allow more space to turn.



### Tether Cord

Always attach the tether cord to your riding gear before starting the snowmobile to help ensure it stops should the operator fall off.

After riding, always remove the tether cord from the vehicle cut-off switch to avoid unauthorized use by children or others and to prevent starting in a closed environment (ex: garage).

### Braking

Braking performance may vary suddenly under certain conditions. For example, the level of regenerative braking is continuously adjusted while driving, which affects overall braking performance. Always remember that the snowmobile braking distance may be affected when riding with a passenger and when loaded with cargo at the rear. Avoid locking the track since this could lead to a loss of control.

Using studs on the track will give you better braking capacity on packed snow or ice but will have no noticeable effect on soft snow. Refer to *Snowmobiles Equipped with Traction Enhancing Products* subsection for track studding application.

### Parking Brake

Always engage the parking brake before starting the vehicle. The parking brake should be used whenever the snowmobile is parked.

Make sure the parking brake is fully disengaged before operating the snowmobile. When you ride the vehicle, brake pads that are caused to drag by a continuous pressure on the lever may cause damage to the brake system and cause loss of braking capacity or fire.

---

## Programmable D.E.S.S. Key

The Programmable D. E. S. S. Key can be programmed to limit the speed of the snowmobile and the motor output. This can enable first-time users and less experienced operators to learn how to operate while gaining the necessary confidence and control.

Visit your BRP authorized dealer to see if this accessory is available for your model.

## Carrying Loads

Carrying loads on the vehicle affects the vehicle handling, stability, autonomy and braking distance. Appropriate loading and weight distribution are therefore important.

When carrying loads it is very important to follow the recommendations:

- Never exceed the maximum cargo capacity. Refer to the *Technical Specifications* subsection for the applicable cargo load capacity of your snowmobile.
- Always adjust the suspensions according to the cargo load. Refer to *Tune Your Ride* subsection for more details.
- Never carry a load unless it is properly secured using a BRP LinQ certified accessory. Compatible accessories which are not BRP certified may not be considered as fit for this purpose.
- Always reduce your speed, turn gradually and allow longer braking distance when carrying loads.



### WARNING

Failure to follow these recommendations when carrying loads could lead to a loss of control and possibly in a tip over.

## Towing Loads

### For Expedition Electric model only

Towing loads affects the vehicle handling, stability and braking distance. Appropriate loading and weight distribution are therefore important.

When towing a load it is very important to follow the recommendations:

- Always use a rigid tow bar to tow a cargo carrier or an accessory.
- Never tow a load using a rope. Using a rope would result in a collision between the load and the snowmobile and possibly in a tip over in case of a rapid deceleration or on a downward slope.
- Never tow a load by attaching it directly to the bumper. Use only the hitch to tow a load. Make sure that the cargo carrier hitch is compatible with the one on the vehicle. Use security chains or cables to secure the cargo carrier with the vehicle. Avoid excessive slack in the chains or cables, it could break and snap back.
- Never exceed the vehicle maximum tow capacity. Refer to *Safety Information on the Vehicle* or *Technical Specifications* subsections for the applicable towing capacity of your snowmobile.

- 
- Never exceed the tongue weight capacity, if applicable.
  - Always make sure load is evenly distributed and safely secured on the cargo carrier. Make sure there is at least some weight on the tongue, if applicable.
  - Always adjust the suspensions according to the weight on the tongue, if applicable. Refer to *Tune Your Ride* subsection for more details.
  - Reduce your speed and turn gradually. Avoid hills and rough terrain. Riding this vehicle with a cargo carrier substantially increases the risk of toppling, especially on inclined slopes. Never attempt steep hills.
  - Allow more distance for braking, especially on inclined surfaces and when a passenger is on board. Be careful not to skid or slide.
  - Use caution when disconnecting a loaded cargo carrier; its load may topple on you or others.



#### WARNING

Failure to follow these recommendations when carrying or towing loads could lead to a loss of control and possibly in a tip over.

Any towed accessory should have reflectors on both sides and at the rear.

Check country transport regulations for brake light(s) requirements.

## Towing Another Snowmobile

**For Expedition Electric model only**

If a snowmobile is disabled and must be towed, in an emergency situation only, a rope can be used

- For snowmobiles with internal combustion engine, remove the drive belt. Refer to *Maintenance Procedures* of the applicable operator's guide for more details.
- For electric snowmobiles, do **not** exceed the maximum recommended towing speed of 10 km/h (6 mph).
- Attach the rope to the ski legs (spindles), **not** to the skis. If the ski legs are not accessible, attach the rope to the bumper.
- Have someone sit on the towed snowmobile to steer and activate the brake if needed.
- Tow at low speed with extra caution.

### WARNING

Never transport this vehicle with the track on the ground or so that the propulsion system can rotate at a speed higher than 10 km/h (6 mph). This can cause the motor to generate a voltage which can do significant damage, cause the motor to overheat and cause the vehicle to have erratic behavior. In rare cases, extreme overheating can ignite surrounding components.

### NOTICE

When towing snowmobiles with internal combustion engine, always remove the drive belt of the snowmobile that is to be towed to prevent damage to its belt and drive system.

In some areas, it may be illegal to do so. Check with state or local authorities.

---

## Accessories and Modifications

Any modifications or addition of accessories approved by BRP may affect the handling of your vehicle. It is important to take the time to get familiar with the vehicle once modifications are made to understand how to adapt your driving behavior accordingly.

Avoid installing equipment not specifically approved by BRP for the vehicle and avoid unauthorized modifications. These modifications and equipment have not been tested by BRP and may create hazards. For example, they could:

- Create a loss of control and increase risk of crash
- Cause overheating or short circuits increasing the risk of fire or burn injuries
- Affect the protection features provided by the vehicle
- Affect the behavior of the trailer when the vehicle is transported
- Cause a risk of losing objects on the road when transported.

Your vehicle may also become illegal to ride.

Ask your authorized BRP dealer for suitable available accessories for your vehicle.

For safety reasons, some BRP accessories must be installed by a BRP dealer but if you decide to install the accessory by yourself, when not required to be done by the dealer, it is important to follow all the instructions carefully and, if applicable, understand all the information on how to use the product or for servicing.

If the accessory has been installed on your vehicle by another person than you, BRP strongly recommends you to read the corresponding instruction sheet as there may be more for information on how to use it safely or for the servicing.

The instruction sheets can be found at this address:

- <https://instructions.brp.com>

### Unauthorized Modifications

Any modifications or equipment installation not specifically approved by BRP performed to the low voltage electrical system of this vehicle may affect the high voltage battery management system and impact the vehicle safety, life expectancy and warranty.



Do not install equipment not specifically approved by BRP or perform unauthorized modifications of this vehicle electrical systems

---

## RIDE SAFELY

### Rider Position (Forward Operation)

Your riding position and balance are the two basic principles of making your snowmobile go where you want it to. When turning on the side of a hill, you and your passenger must be ready to shift body weight to help it turn in the desired direction. Operator and passenger must never attempt this maneuvering by placing feet outside of the vehicle. Experience will teach you how much lean to put into turns at different speeds and how much you will have to lean into a slope to maintain proper balance.

Generally, the riding position for best balance and control is sitting. However, the posting, kneeling or standing positions are also used under certain conditions.



**WARNING**

Do not attempt any maneuvers if they are beyond your abilities.

### Sitting

Feet on the running boards, body midway back on seat is an ideal position when operating the snowmobile over familiar, smooth terrain. Knees and hips should remain flexible to absorb shocks.



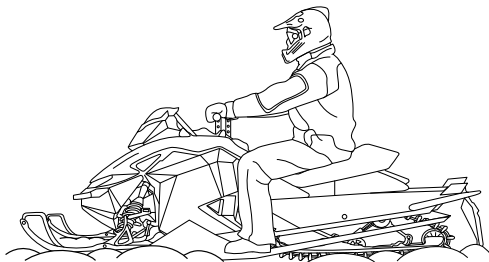

### Posting

A semi-sitting position with the body off the seat and the feet under the body in a sort of squatting posture, thus allowing the legs to absorb the shocks when traveling over uneven terrain. Avoid abrupt stops.



### Kneeling

This position is achieved by placing one foot firmly on the running board and the opposite knee on the seat. Avoid abrupt stops.



## Standing

Place both feet on the running boards. Knees should be flexed to absorb the shock from surface bumps. This is an effective position to see better and to shift weight as conditions dictate. Avoid abrupt stops.

## Rider Position (Reverse Operation)

When operating in reverse:

- Ensure the path behind is clear of obstacles or bystanders before proceeding in reverse.
- BRP recommends sitting on your snowmobile when operating in reverse.
- Avoid standing up. Your weight could shift forward against the accelerator lever while operating in reverse, causing an unexpected acceleration. Unexpected acceleration when snowmobile operates in reverse can cause a loss of control.

Fast reverse while turning could result in loss of stability and control.

## Riding with Passenger(s)

This vehicle is designed for one (1) operator and as many passengers as there are seats with straps or handholds installed on the vehicle conforming to SSSC standards. Passenger must only sit on designated passenger seat.

### WARNING

- Never carry a passenger on a seat not approved by BRP.
- Never allow anyone to sit between the handlebar and the operator.

Even when a passenger is allowed, this person must be physically fit for snowmobiling.

---

Any passenger must always be able to firmly lay his feet on the footrests and keep his hands on the handholds or seat strap when seated. Respecting those physical criteria is important to ensure that the passenger is stable and to reduce the risks of ejection. Falls can result in severe injury or death.

The operator has a responsibility to ensure the safety of his passenger and should inform the passenger about snowmobiling basics.

Before riding the vehicle, adjust suspension according to weight. Refer to *Tune Your Ride* subsection for more details.

Ask your passenger to inform you to slow down or stop immediately if he feels uncomfortable or insecure during the ride.

When going over bumps, rider (s) may raise their body slightly off the seat to absorb the shocks with their legs.

An unforeseen bump can cause a passenger to be ejected from the vehicle. Remind your passenger to lean into the turn with you, without causing the vehicle to topple. Be extremely careful, go more slowly and check the passenger frequently. Keep a watchful eye on your passenger while riding.

Braking ability and steering control are reduced when riding with a passenger. Decrease speed and allow extra space to maneuver.

## **Riding Alone**





Venturing out alone with your snowmobile could also be hazardous. You could run out of power, have an accident or damage your snowmobile. Remember, your snowmobile is capable of traveling further in half an hour than you may be able to walk in a day. Use the “buddy system.” Always ride with a friend or member of your snowmobile club. Even then, tell someone where you are going and the approximate time you plan to return.

## Riding in a Group

Before starting out, designate a “trail boss” to lead the party and another person to follow-up at the end of the party. Ensure that all members of the party are aware of the proposed route and destination. When riding with others, limit your abilities to the experience of others. Never overtake the trail boss or, for that matter, any other snowmobile. Use down-the-line hand signals to indicate hazards or intent of direction change. It’s important to keep a safe distance between each snowmobile but each one behind the leader should know the position of the machine ahead.

## Hand Signals

Every snowmobiler should relay any signal to the ones behind.

<p><b>STOP</b> Raise either hand straight above your head.</p> 	<p><b>LEFT TURN</b> Extend your left hand straight out in the proper direction.</p> 
<p><b>RIGHT TURN</b> Extend the left arm and raise the hand to a vertical position so it</p> 	<p><b>SLOWING DOWN</b> Left hand extended out and down from the side of the body</p> 

---

forms a right angle at the elbow.	with downward flapping motion of hand to signal warning or caution.
-----------------------------------	---

## Avoiding Collisions

Always be on the look-out for the unexpected. Operate defensively. Scan constantly for people, objects, conditions and upcoming vehicles. On the trail, always stay on the appropriate side - as per country regulation - to avoid collision, especially when the field of vision is reduced (e. g., before a hilltop or curve). Use extra caution whenever off-trail.

Always keep a safe distance from other snowmobiles and bystanders. Tailgating another snowmobile should be avoided. If the snowmobile in front of you slows down for any reason, its operator and passenger could be harmed through your neglect. Maintain a safe stopping distance between you and the snowmobile in front of you. Depending on the terrain condition, stopping may require a little more space than you think. Play it safe. Be prepared to use evasive driving.

On land or water, fog or visibility-limiting snow can form. If you must proceed into the fog or heavy snow, do so slowly with your lights on and watch intently for hazards. If you are not sure of your way, do not proceed. Keep a safe distance behind other snowmobilers to improve visibility and allow sufficient reaction time.

### Riding Behaviors

Injury or death may result to the snowmobile operator, passenger or bystander if the snowmobile is used in risky conditions which are beyond the operator's, passenger's or snowmobile's capabilities or intended use.

Remember, promotional material may show risky maneuvers performed by professional riders under ideal and controlled conditions. You should never attempt any such risky maneuvers if they are beyond your level of riding ability.

Jumping can be a hazardous situation. It requires practice and should be done in a known and controlled environment. Never attempt jumping on a trail. A loss of control could lead to an impact with rocks, trees or another snowmobile. When jumping be prepared for landing to absorb the shock. Brace yourself for the impact. Your knees must be flexed to act as shock absorbers.

An uneven or mined surface in the trail could be enough to kick the snowmobile upward and cause a loss of control. Trying to accelerate above the traction limit allowed by the track and trail will cause track spin which leaves an irregular trail surface. So protect the other users by not spinning the track in the trail.

### Speeding

Excessive speed and reckless driving can be fatal. Always adjust your speed according to snow conditions and circumstances. In many cases, you cannot react or respond quickly enough to the unexpected. Always ride at a speed which is suitable to the trail, weather conditions and your own ability. Know your local rules. Speed limit may be in effect.

### Moving Parts

Stay away from the track. Personal injury will result if contact is made with the rotating track.

---

To prevent serious injury to individuals near the snowmobile:

- Never stand behind or near a moving track
- Always use a wide-base snowmobile stand with a rear deflector panel if it is necessary to rotate the track
- When the track is raised off the ground, only run it at the lowest possible speed. Centrifugal force could cause debris, damaged or loose studs, pieces of torn track, or an entire severed track to be violently thrown backwards out of the tunnel with tremendous force

- Never operate the vehicle without the brake disk guard securely installed
- Never operate the vehicle with the side panels opened, or the hood removed

## **Know Terrain and Riding Variations**

### **Groomed Trail**

On a maintained trail, sitting is the preferred riding position. Do not race and, above all, keep to the appropriate side of the trail. Be prepared for the unexpected. Observe all trail signs. Do not zigzag from one side of the trail to the other.



### Ungroomed Trail

Unless there has been a fresh snowfall you can expect “washboard” and snowdrift conditions. Taken at excessive speeds, such conditions can be physically harmful. Slow down. Hold on the handlebar and assume a posting position. Feet should be under the body assuming a crouched position to absorb any jarring effect. On longer stretches of “washboard” trails, the kneeling position of one knee on the seat can be adopted. This provides a certain amount of comfort, while at the same time keeps the body loose and capable of vehicle control. Beware of hidden rocks or tree stumps partially hidden by a recent snowfall.

---

## Deep Snow

In deep powder snow, your vehicle could begin to sink. If this occurs, turn in as wide an arc as possible and look for a firmer base. If you do start to sink, do not spin your track as this makes the vehicle sink deeper. Instead, turn the vehicle off, get off and move the back of the vehicle onto new snow. Then tramp a clear path ahead of the vehicle. A few feet will generally suffice. Restart the vehicle. Assume the standing position and rock the vehicle gently as you steadily and slowly apply the accelerator. Depending on whether the front or rear end of the vehicle is sinking, your feet should be placed on the opposing end of the running boards. Never place foreign material beneath the track for support. Do not allow anyone to stand in front of or to the rear of the snowmobile while it is operating. Stay away from the track. Personal injury will result if contact is made with the revolving track.

## Frozen Water

Traveling frozen lakes and rivers can be fatal. Avoid waterways. If you are in an unfamiliar area, ask the local authorities or residents about the ice condition, inlets, outlets, springs, fast moving currents or other hazards. Never attempt to operate your snowmobile on ice that may be too weak to support you and the vehicle. Operating a snowmobile on ice or icy surfaces can be very dangerous if you do not observe certain precautions. The very nature of ice is foreign to good control of a snowmobile or any vehicle. Traction for starting, turning or stopping is much less than that on snow. Thus, these distances can be multiplied manyfold. Steering is minimal, and uncontrolled spins are an ever present danger. When operating on ice, drive slowly with caution. Allow yourself plenty of room for stopping and turning.

### Slush

Slush should be avoided at all times. Always check for slush before starting across any lake or river. If dark spots appear in your tracks, get off the ice immediately. Ice and water can be thrown rearward into the path of a following snowmobile. Getting a vehicle out of a slush area is strenuous and in some cases, impossible.

### Uphill

There are two types of hills you can encounter — the open hill on which there are few trees, cliffs or other obstacles, and a hill that can only be climbed directly. On an open hill, the approach is to climb it by side hilling or slaloming. Approach at an angle. Adopt a standing position with both feet on the same running board. Keep your weight on the uphill side at all times. Maintain a steady, safe speed. Continue as far as you can in this direction, then switch to an opposite hill angle and riding position.

A direct climb could present problems. Choose the standing position, accelerate before you start the climb and then reduce accelerator pressure to prevent track slippage.

In either case, the vehicle speed should be as fast as the incline demands. Always slow down as you reach the crest. If you cannot proceed further, don't spin your track. Apply the parking brake, turn the vehicle off, free the skis by pulling them out and downhill, place the rear of the snowmobile uphill, restart the vehicle, release the parking brake and ease it out with slow, even accelerator pressure. Position yourself to avoid tipping over, then descend.

---

## **Downhill**

Downhill driving requires that you have full control of your vehicle at all times. On steeper hills, keep your center of gravity low and both hands on the handlebar. Maintain slight accelerator pressure and allow the machine to run downhill with the vehicle operating. If a higher than safe speed is reached, slow down by braking but apply the brake with frequent light pressure. Never lock the track.

## **Side Hill**

When crossing a side hill or traversing up or downhill, certain procedures must be followed. All riders should lean towards the slope as required for stability. The preferred operating position is the standing position, with both feet on the running board that is facing uphill. Be prepared to shift your weight quickly as needed. Side hills and steep slopes are not recommended for a beginner or a novice snowmobiler.

## **Avalanche Hazard**

When riding on mountainous terrain, be aware of the risk of avalanches. Avalanches vary in size and shape and generally occur in steep terrain and on unstable snow.

New snow, animals, people, wind and snowmobiles can all trigger an avalanche. Avoid high marking or traversing steep terrain when avalanche conditions are possible. When in unstable snow conditions, travel should be restricted to lower angle slopes. Wind formed cornices should be avoided. Staying off unstable conditions is the key to safe mountain riding. Be aware of the conditions and dangers on a daily basis when in the mountains. Check local avalanche forecasts and threats each day before heading out to ride and heed forecasters advice.

You should always carry and know how to use a snow shovel, probe and avalanche beacon while riding on mountains.

### Bright Sunshine

Bright sunny days can considerably reduce your vision. The glare from sun and snow may blind you to the extent that you cannot easily distinguish ravines, ditches or other obstacles. Goggles with colored lenses should always be worn under these conditions.

### Night Rides

The amount of natural and artificial light at a given time can affect your ability to see or to be seen. Be extra cautious. Drive at speeds that will allow you to stop in time when you see an unknown or dangerous object ahead. Stay on established trails and never operate in unfamiliar territory. Be sure both headlights and taillight are working and clean.

### Unfamiliar Territory

Whenever you enter an area that is new to you, drive with extreme caution. There may be obstructions hidden beneath the snow. Go slow enough to recognize potential hazards such as fences or fence posts, brooks crossing your path, rocks, sudden dips, guy wires and countless other obstacles which could result in a termination of your snowmobile ride.

Driving off established trails and in the woods requires reduced speed and increased vigilance. Driving too fast in an area can make even minor obstacles very hazardous. Even hitting a small rock or stump could throw your snowmobile out of control and cause injury to its riders. Even when following existing tracks, be cautious. Travel at a speed so you can see what is around the next bend or over the top of the hill.

---

## **Hidden Wires**

Always be on the lookout for hidden wires, especially in areas that may have been farmed at one time or another. Too many accidents have been caused by running into wires in the fields, guy wires next to poles and roads, and into chains and wires used as road closures. Slow speeds are a must.

## **Riding Uneven Surfaces**

Unplanned jumps of snowdrifts, snowplow ridges, culverts, indistinguishable objects or sudden drops in the trail can be dangerous. A good way to help see these terrain variations is to wear the proper color lenses or face shields and by operating at a lower speed.

Crouch (stand) towards the rear of the vehicle and keep the skis up and straight ahead. Apply partial acceleration and brace yourself for the impact. Knees must be flexed to act as shock absorbers.

## **Road Crossing**

Your snowmobile is not designed to operate or turn on pavement of public streets, roads or highways. Avoid road traveling. If you must do so, and it is permitted, reduce your speed and stay on the edge where you can find snow to help maintain directional control.

As snowmobile trails often cross roadways it is important for riders to know the proper crossing procedures. When approaching a roadway, signal to others that you are stopping at the intersection and slowly come to a complete stop back from the road's edge. In some cases, you will be approaching the road from a ditch or snowbank. Choose a place where you know you can climb without difficulty. Stop completely at the top of the bank and wait for all traffic to clear. Then, look carefully in both directions before crossing at a 90° angle. If needed, assume a standing position to look both ways. Be wary of parked vehicles. When you are certain that the road is clear proceed straight across the intersection without hesitation. Each rider needs to come to a complete stop, look both ways and then proceed when the roadways is clear of oncoming traffic.

### **Railroad Crossing**

Never ride on railroad tracks. It is dangerous and may violate applicable laws. Railroad tracks and railroad rights-of-way are private properties. A snowmobile is no match for a train. Before crossing a railroad track, stop, look and listen.

### **Respect of the Wildlife**

Snowmobile tracks provide firm ground over which animals can travel from area to area. Do not violate this privilege by chasing or harassing wildlife. Fatigue and exhaustion can lead to an animal's death. Avoid areas posted for the protection or feeding of wildlife. If you happen to be fortunate enough to see an animal, stop your snowmobile and observe quietly.

---

## PRACTICE EXERCISES

### Where to Practice Exercises

Find a suitable area to practice the exercises. Ensure the area meets the following requirements:

- No traffic
- No obstacles
- Hard packed snow
- Ample space to maneuver

### Exercises to Practice

Practice alone the following exercises after having done the entire pre-ride inspection. Always start and stop the vehicle according to the instructions in *Starting the Vehicle* and *Turning Off the Vehicle* in *Starting and Driving*. Don't forget to attach the tether cord to your jacket.

### Using the Emergency Stop Switch

Purpose: Become familiar with the operation of accelerator lever and become familiar with using the emergency stop switch.

Directions:

- With the parking brake engaged, start the vehicle.
- Use the emergency stop switch to disable the vehicle propulsion system. Press the switch with your right thumb while keeping your hand on the handgrip.
- Restart the vehicle and repeat the exercise.

Tips for additional practice:

- Press the emergency stop switch without looking at it.



### Starting, Stopping and Basic Handling

Purpose:

- Learn accelerator lever control and how to get the vehicle moving.
- Become familiar with low speed deceleration and braking.

If you feel like you are losing control while doing this exercise, release the accelerator lever to stop accelerating and apply the brake as needed to slow down. You can also use the emergency stop switch to cut power entirely.

Directions: At first, you will only use the accelerator lever for a moment at a time, then release it and coast.

- Start the vehicle and release the parking brake lever.
- Slowly apply accelerator lever until the vehicle starts to creep forward. As soon as you start moving release the accelerator lever and coast, then press the brake lever to stop.
- Continue with this part of the exercise until you are comfortable with pressing and releasing the accelerator lever.

### Vehicle Stop While in Motion

Purpose: Become familiar with using the emergency stop switch when in motion so you know how the vehicle will react if you need to use it later.

---

Directions:

- Partway down the straightaway, while operating at 8 km/h (5 mph), toggle the stop switch to the OFF position and coast to a stop.
- Restart the vehicle and repeat the exercise. Try increasing your speed (to a maximum of 20 km/h (12 mph) before using the stop switch.

In an emergency, the snowmobile can be stopped by pressing down on the emergency stop switch or by pulling the tether cord cap from the cut-off switch, while applying brake.

## Basic Turns

Purpose: Get comfortable turning in a controlled manner on both sides.

Directions:

- Roll in a straight line at low speed and make a wide arcing turn. Make sure there is enough space to perform the entire turn.
- Repeat right and left turns and maintain a steady speed below 8 km/h (5 mph). Hold the accelerator lever to maintain your low speed.
- Leaning forward and into the curve may help you to turn the handlebar more easily.

## Quick Stops

Purpose:

- Become familiar with the vehicle braking ability.
- Learn to apply the brake with maximum efficiency.

This exercise is like what you did before, except you'll be applying the brake more firmly, working up to braking at the maximum without locking the track rotation. Always release the accelerator lever completely for quick stops.

Directions:

- Start at one end of the straightaway and accelerate to 8 km/h (5 mph). Partway down the straightaway, release the accelerator lever completely and brake quickly.
- Keep head and eyes up, keep the handlebar straight and do not release the brake until fully stopped.
- Repeat, increasing your speed and braking harder. When you feel that the rotation of the track will be stopped you need to release the pressure on the brake lever. To maintain control, you need to keep the track in rotation.

### Operating in Reverse

Purpose: Become familiar with the vehicle handling and turning radius in reverse.

Directions:

- Activate the reverse mode and remain seated. Refer to *SWITCHING TO AND FROM REVERSE* in *STARTING AND DRIVING*.
- Check that the area behind you is clear. While looking backwards, slowly reverse and stop by releasing the accelerator lever and using the brake, just like when operating normally.
- Keep your speed low and do not back up for long distances.
- Repeat the reverse and stop in straight line until you get comfortable.
- Once you are comfortable with reversing in straight line, you can slowly reverse while turning the handle bar.

---

## TRANSPORTING THE VEHICLE

Many types of trailer can be used to transport a vehicle. Whether using tilt-bed, flatbed or enclosed trailers, always proceed with precaution when driving the vehicle on and off of it.

Always anchor the vehicle securely, front and rear, even on short hauls. Use appropriate tie-down straps only. Make sure all equipment is securely fastened. Cover the vehicle to prevent road grime from causing damage.

Make sure the trailer meets state or provincial requirements. Ensure the hitch and safety chains are secured and the brake, turn indicators and clearance lights are functional.

 **WARNING**

Make sure all seats, accessories and cargo are properly secured, or remove it to prevent from falling on the road and creating a hazard for following vehicles.

 **WARNING**

Do not transport the vehicle facing backwards. If the vehicle is transported facing backwards, the wind may cause damage to the windshield or even loss of the windshield.

The vehicle's electric motor is mechanically connected to the snowmobile track and can generate electricity when rotated.

**AVOID PULLING OR PUSHING THE VEHICLE TO CAUSE THE TRACK TO MOVE WHEREVER POSSIBLE. IF NECESSARY, THE VEHICLE MAY BE TEMPORARILY PULLED AT A SPEED NO GREATER THAN 10 km/h (6 mph).**

The vehicle must be secured in an upright position whenever it is being lifted or manipulated. Never use metal or conductive components to lift, manipulate, or secure the vehicle.

## SAFETY INFORMATION

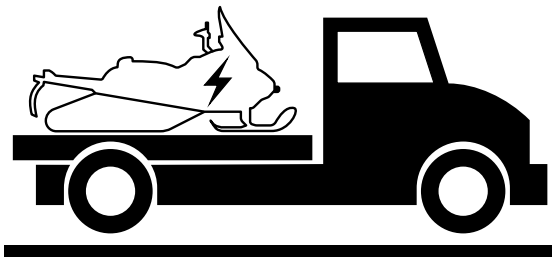

2

A flatbed truck or comparable transport vehicle is recommended to transport the vehicle to prevent the track from moving. The vehicle shall be secured onto the platform facing forward using the ski legs, not the skis, and the rear suspension. A strap can be used on each of the front ski legs (spindles) or 1 strap can be passed behind both ski legs (spindles). Pass a strap through the rear suspension to anchor the track on the platform. Alternatively, the 2 footrests can be used at the lifting points.

### NOTICE

Front and rear bumpers should not be used as sole attachment points when towing a snowmobile on a trailer/flatbed platform.

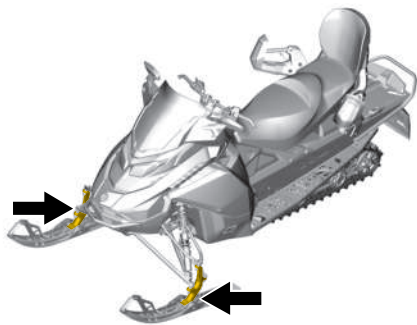

Secure the vehicle at the locations shown.

## Pushing or Pulling the Vehicle

### WARNING

Never transport this vehicle with the track on the ground or so that the propulsion system can rotate at a speed higher than 10 km/h (6 mph). This can cause the motor to generate a voltage which can do significant damage, cause the motor to overheat and cause the vehicle to have erratic behavior. In rare cases, extreme overheating can ignite surrounding components.

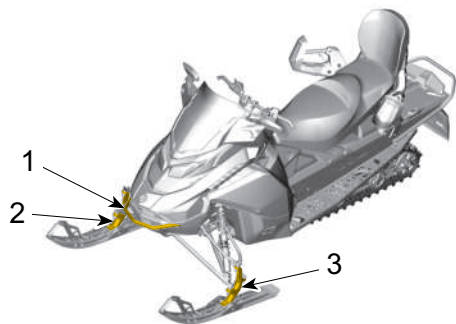

1. *Front bumper*
2. *Ski leg (spindle)*
3. *Ski leg (spindle)*

---

If the vehicle cannot be lifted onto the flatbed, or if a flatbed is not available and the vehicle must be recovered, it may be winched or temporarily towed at a speed below 10 km/h (6 mph) using a tow rope attached to both ski legs (spindles), not the skis. If the ski legs are not accessible, the tow rope can be attached to the front bumper.

If possible, the parking brake should be applied with a cargo sled or sliding carpet installed under the track to prevent them from turning.



### IMPORTANT ON-PRODUCT LABELS (CANADA/UNITED STATES)

#### Vehicle Safety Labels

These labels are affixed to the vehicle for the safety of the operator, passenger and bystanders.

The following labels are on your vehicle and they should be considered permanent parts of the vehicle. If missing or damaged, the decals can be replaced free of charge. Visit an authorized BRP snowmobile dealer.

**NOTE:**

In the event of any discrepancy between this guide and the vehicle, the safety labels on the vehicle have precedence over the labels in this guide.

---

## Disk Guard - Warning Label



Disk Guard – Warning Label



## Starting Procedure - Warning Label

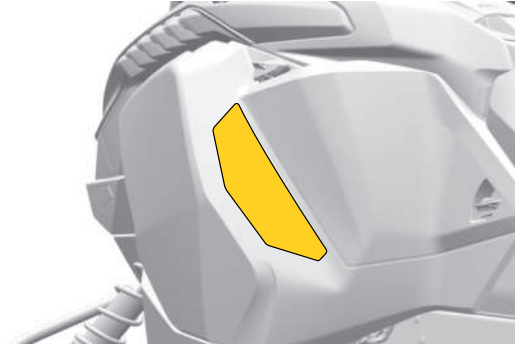
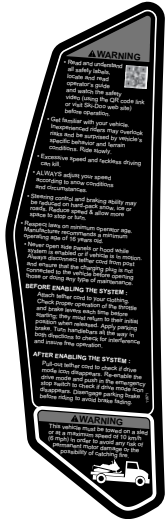

---

## Label Text

### WARNING

Read and understand all safety labels, locate and read operator's guide and watch the safety video (using the QR code link or visit Ski-Doo web site) before operation.

Get familiar with your vehicle. Inexperienced riders may overlook risks and be surprised by vehicle's specific behavior and terrain conditions. Ride slowly.

Excessive speed and reckless driving can kill.

**ALWAYS** adjust your speed according to snow conditions and circumstances.

Steering control and braking ability may be reduced on hard-pack snow, ice or roads. Reduce speed & allow more space to stop or turn.

Respect laws on minimum operator age. Manufacturer recommends a minimum operating age of 16 years old.

Never open side panels or hood while system is enabled or if vehicle is in motion. Always disconnect tether cord from post and ensure that the charging plug is not connected to the vehicle before opening those or doing any type of maintenance.

**BEFORE ENABLING THE SYSTEM:**

## Passenger Safety - Warning Label

Attach tether cord to your clothing. Check proper operation of the throttle and brake levers each time before starting; they must return to their initial position when released. Apply parking brake. Turn handlebars all the way in both directions to check for interference and ensure free operation.

### AFTER ENABLING THE SYSTEM:

Pull out tether cord to check if drive mode icon disappears. Re-enable the drive mode and push in the emergency stop switch to check if the drive mode icon disappears. Disengage parking brake before riding to avoid brake fading.



**WARNING**

This vehicle must be towed on a sled or at a maximum speed of 10 km/h (6 mph) in order to avoid any risk of permanent motor damage or the possibility of catching fire.

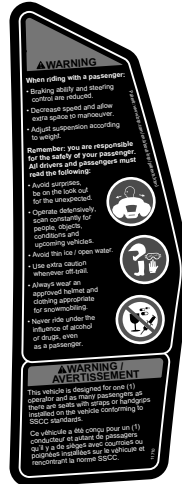

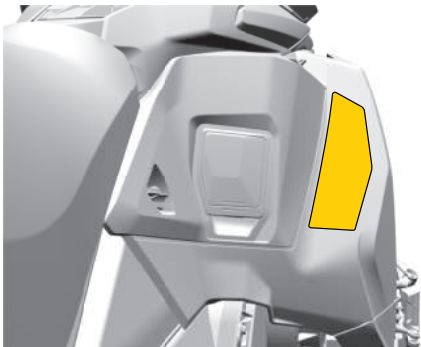

## Label Text

### WARNING

When riding with a passenger:

Braking ability and steering control are reduced.

Decrease speed and allow extra space to maneuver.

Adjust suspension according to weight.

Remember: you are responsible for the safety of your passenger. All drivers and passengers must read the following:

Avoid surprises, be on the lookout for the unexpected.  
Operate defensively, scan constantly for people, objects, conditions and upcoming vehicles.

Avoid thin ice / open water.

Use extra caution whenever off-trail.

Always wear an approved helmet and clothing appropriate for snowmobiling.

Never ride under the influence of alcohol or drugs, even

**⚠ WARNING**

This vehicle is designed for one (1) operator and as many passengers as there are seats with straps or handgrips installed on the vehicle conforming to SSCC standards.

## Maximum Cargo Load and Towing Capacity- Warning Label

For Grand Touring Electric model only

2

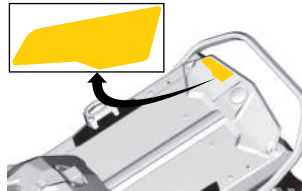

## For Expedition Electric model only

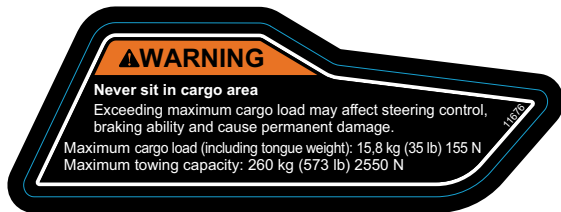

**Cargo Area – Warning Label**



**Label Location**

## Rotating Track - Warning Label

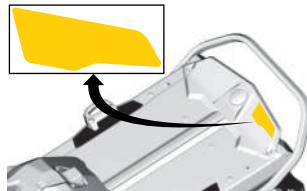
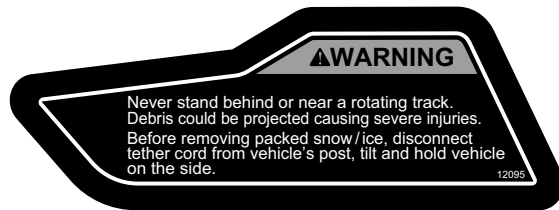



## Charging - Caution Label

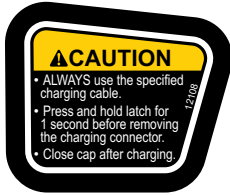

## Electric Shock - Warning Label



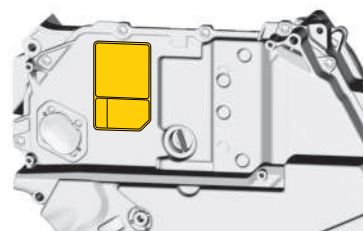
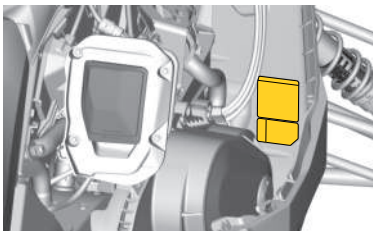
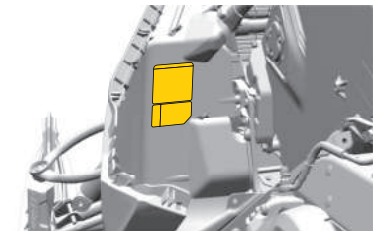

**Label Text**

## WARNING

To avoid electric shock that could lead to severe injury or death:

NEVER service the High Voltage (HV) system yourself. HV system requires special tools, appropriate personal protective equipment and training. The HV system must be serviced only by a qualified Bombardier Recreational Products technician.

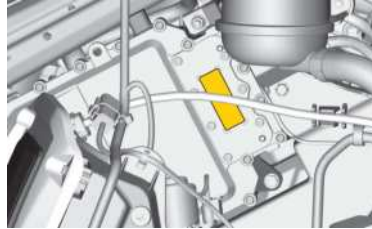

2



## Battery Warning Labels

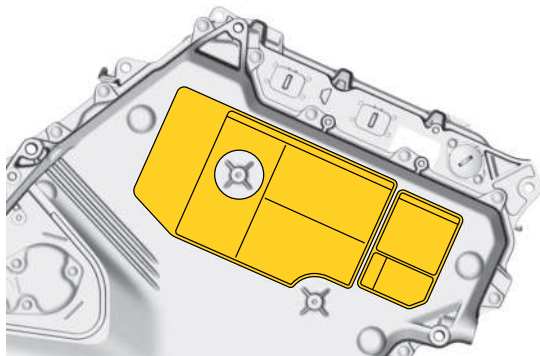



High voltage inside / Alkaline Electrolyte

To avoid the risk of **SERIOUS INJURY** or **DEATH** from **ELECTRIC SHOCK**, **ARC FLASH** or **FIRE**, always follow these precautions:

**NEVER** attempt to open, modify or disassemble this battery pack. This battery pack is not serviceable.

**NEVER** use this battery pack for other than its intended purpose in this vehicle.

**NEVER** puncture or expose this battery pack to impact.

**NEVER** expose this battery pack to fire or a source of heat.

**NEVER** submerge this battery pack in any liquid.

**NEVER** dispose of this battery pack illegally. Recycling or disposal of lithium-ion batteries requires special facilities. Improper disposal of this battery pack may also result in environmental damage.

**NEVER** come in contact with a leaking battery pack.

**ALWAYS** keep out of reach of children.

**ALWAYS** follow applicable laws and regulations when transporting, packaging, and storing this battery pack.

**To Qualified EV Technicians:** For replacement of this battery pack, follow the repair manual.

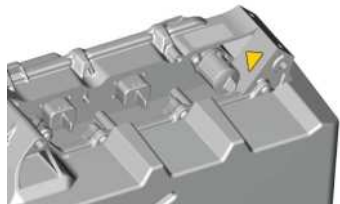
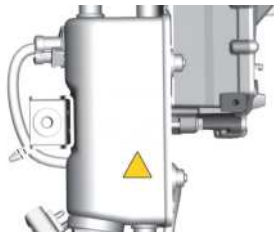

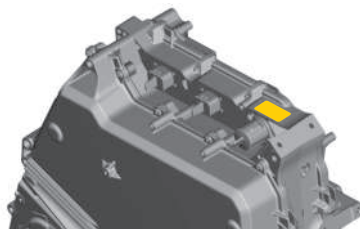

2

S/N: ESSB0000PV000001



EOL test OK

---

P/N:

S/N:

361VDC 8,9kWh Li-ion



Bombardier Recreational  
Products Inc

Fabriqu  au Canada  
Made in Canada

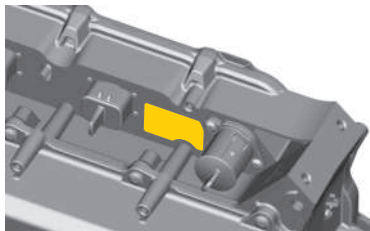

## High Voltage Battery Identification Label



## Adjustment Tools Label

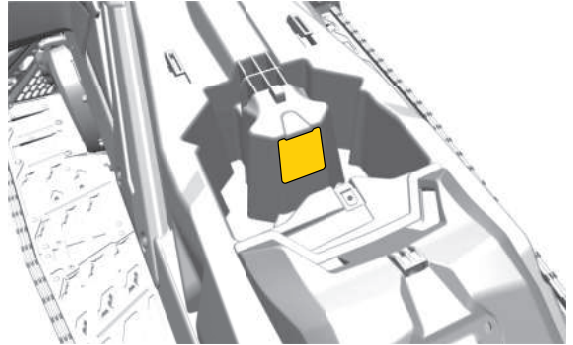
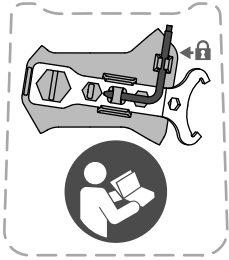

2

---

## Cargo - Warning Label

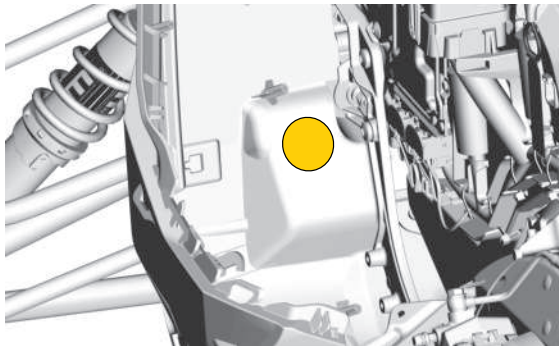

This label indicates that cargo should never be carried in this area.

## California Proposition 65 Tags



## Label Text

**⚠️WARNING:** Operating, servicing and maintaining a passenger vehicle or off-highway motor vehicle can expose you to chemicals including engine exhaust, carbon monoxide, phthalates, and lead, which are known to the State of California to cause cancer and birth defects or other reproductive harm. To minimize exposure, avoid breathing exhaust, do not idle the engine except as necessary, service your vehicle in a well-ventilated area and wear gloves or wash your hands frequently when servicing your vehicle. For more information, go to [www.P65Warnings.ca.gov/passenger-vehicle](http://www.P65Warnings.ca.gov/passenger-vehicle).

**⚠️WARNING:** Battery posts, terminals and related accessories contain lead and lead compounds, which are known to the State of California to cause cancer and birth defects or other reproductive harm. To minimize exposure, wear gloves or wash your hands frequently when servicing your vehicle. For more information, go to [www.P65Warnings.ca.gov](http://www.P65Warnings.ca.gov).

 **WARNING**

Operating, servicing and maintaining a passenger vehicle or off-highway motor vehicle can expose you to chemicals including engine exhaust, carbon monoxide, phthalates, and lead, which are known to the State of California to cause cancer and birth defects or other reproductive harm. To minimize exposure, avoid breathing exhaust, do not idle the engine except as necessary, service your vehicle in a well-ventilated area and wear gloves or wash your hands frequently when servicing your vehicle. For more information, go to: [www.P65Warnings.ca.gov/passenger-vehicle](http://www.P65Warnings.ca.gov/passenger-vehicle).

 **WARNING**

Battery posts, terminals and related accessories contain lead and lead compounds, which are known to the State of California to cause cancer and birth defects or other reproductive harm. To minimize exposure, wear gloves or wash your hands frequently when servicing your vehicle. For more information, go to: [www.P65Warnings.ca.gov](http://www.P65Warnings.ca.gov).

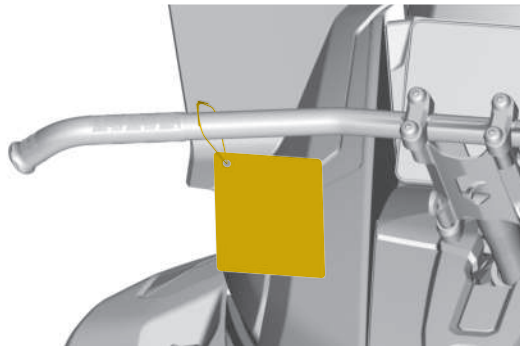

### REPORTING SAFETY DEFECTS

In Canada, if you believe that your vehicle has a defect which could cause a crash or could cause injury or death, you should immediately inform Transport Canada in addition to notifying Bombardier Recreational Products Inc.

If Transport Canada receives similar complaints, it may open an investigation, and if it finds that a safety defect exists in a group of vehicles, it may order a recall and remedy campaign. However, Transport Canada cannot become involved in any individual problems between you, your dealer or Bombardier Recreational Products Inc.

#### *To contact Transport Canada:*



819-994-3328 (Gatineau-Ottawa area  
or internationally)  
Toll free : 1 800-333-0510 (in Canada)



Transport Canada - ASFAD  
330 Sparks Street  
Ottawa, ON  
K1A 0N5



<https://www.tc.gc.ca/recalls>

---

## PRE-RIDE INSPECTION

Perform a pre-ride inspection before each ride to detect potential problems during operation. The pre-ride inspection can help you monitor wear and deterioration before they become a problem. Correct any problems that you discover to reduce the risk of an accident or a malfunction.

### Before Starting

1. Remove snow and ice from body including lights, seat, footrests, controls and instruments.
2. Remove packed snow and ice from the rear suspension using the wrench tool.
3. Verify that skis and steering operate freely. Check corresponding action of skis versus handlebar.
4. All storage compartments must be properly latched and they must not contain any heavy or breakable objects. Hood and side panels must be properly latched.
5. Activate the brake lever and make sure the brake fully applies before the brake control lever

touches the handlebar grip. It must fully return when released.

6. Apply parking brake and ensure it operates properly. Leave parking brake applied.
7. With the D.E.S.S. key removed and parking brake applied, activate the accelerator lever several times to check that it operates easily and smoothly. It must fully return when released.

### After Starting

For proper starting procedure, refer to *STARTING THE VEHICLE* in *STARTING AND DRIVING*.

1. Check headlights (high beam and low beam), taillight, stop light and pilot lamps operation.

**NOTE:**

You may need to apply the parking brake and detach the tether cord from your clothes to check the lights. Once done, return to the controls of the snowmobile, re-attach the tether cord and release the parking brake.

2. Check the emergency stop switch operation.
3. Check the power-off switch operation by pulling the tether cord cap.
4. Release the parking brake.

2

### Pre-Ride Check List

<i>ITEM</i>	<i>OPERATION</i>	✓
Body including seat, footrests, lights, controls and instruments	Check condition and wear and remove snow or ice.	
Skis and steering action	Check for free movement and proper operation.	
Ski runners	Check for abnormal wear.	
Accelerator lever	Check for proper operation.	

<b>ITEM</b>	<b>OPERATION</b>	✓
Brake lever	Check for proper operation.	
Parking brake	Check for proper operation.	
Brake fluid	Check for proper level and no leaks.	
Storage compartment	Check for proper latching and no heavy or breakable objects.	
Track	Check condition and remove snow or ice. For studded tracks, refer to <i>Snowmobiles Equipped with Traction Enhancing Products</i> .	
Slider shoes	Check for abnormal wear.	
Emergency stop switch	Check for proper operation.	
Vehicle power-off switch (tether cord cap)	Check for proper action. Tether cord must be attached to operator clothing eyelet.	



## SAFETY INFORMATION

<i>ITEM</i>	<i>OPERATION</i>	✓
Lights	Check for proper operation.	
Horn button (if equipped)	Check for proper operation.	

2



# **3 ELECTRIC VEHICLE (EV) OVERVIEW - TABLE OF CONTENTS**

---

## **HIGH VOLTAGE COMPONENTS .....3-2**

## **LITHIUM-ION HIGH-VOLTAGE PROPULSION BATTERY .....3-5**

Battery Management System (BMS) ..... 3-6

High-Voltage Battery State of Health (SoH) ..... 3-6

## **CHARGING .....3-8**

Charging Port Connection ..... 3-8

Electric Vehicle Supply Equipment (EVSE) ..... 3-9

Charging the Vehicle. .... 3-10

Removing the Charging Cable ..... 3-11

Charging Best Practices ..... 3-12

Charging Status and Battery State of Charge ..... 3-13

Power Sources ..... 3-15

## **STARTING AND DRIVING ..... 3-16**

Starting the Vehicle. .... 3-16

Switching to and from Reverse. .... 3-17

Standby Mode ..... 3-17

Regenerative Braking ..... 3-18

Performance Gauge ..... 3-18

Vehicle Range ..... 3-19

Turning OFF the Vehicle. .... 3-20

## **DIFFERENCES BETWEEN ELECTRIC VEHICLES AND VEHICLES WITH INTERNAL COMBUSTION ENGINES..... 3-21**

---

## HIGH VOLTAGE COMPONENTS

 **WARNING**

The high-voltage components on the vehicle should only be serviced by an authorized service technician. Do not tamper with the high-voltage components in any way. Contact an authorized BRP dealer for servicing.

 **WARNING**

Your vehicle is designed to withstand wet conditions, including rainfall, snow or puddles. However, submersion in water past the floor of the chassis E module can cause damage or render the vehicle temporarily inoperable. If this occurs, stop using the vehicle. The vehicle should be inspected by a BRP dealer prior to next ride. Contact local emergency service for immediate assistance if any signs of thermal event or hardware failure occur.

 **WARNING**

This vehicle is equipped with an electric motor capable of generating a voltage when rotated. The motor is mechanically connected at all times to the snowmobile track. The vehicle should not be pulled or towed at a speed above 10 km/h (6 mph) or moved in a way that could cause the track to move.

 **WARNING**

If the vehicle has been involved in a crash, do not tow the vehicle at any speed. In addition to the risk of generating voltage, further damage could occur to the motor or the inverter.

# ELECTRIC VEHICLE (EV) OVERVIEW



## WARNING

The vehicle shall only be charged using an EVSE or charging station equipped with a UL2231 compliant Charge Current Interruption Device (CCID) or a Residual Current Device (RCD).

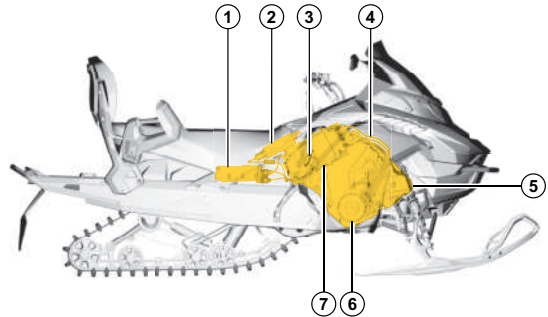

### Typical - Model with SC-5 120 Suspension Shown

1. High-voltage charger
2. High-voltage heater
3. High-voltage charging socket
4. High-voltage cables
5. High-voltage battery pack
6. High-voltage electric motor
7. High-voltage inverter

---

High voltage cables on the vehicle can be identified by their orange color.



**WARNING**

Do not manipulate, cut or otherwise damage the orange high-voltage cables. Always treat the orange high-voltage cables as if they were live and powered.

**NOTE:**

The warranty will be voided if any high voltage components are opened by anyone other than an authorized BRP dealer.

## LITHIUM-ION HIGH-VOLTAGE PROPULSION BATTERY

### WARNING

The high-voltage battery should only be serviced by an authorized service technician. Do not open or tamper with the battery in any way. Contact an authorized BRP dealer for battery servicing.

### WARNING

Do not use the high-voltage battery as a stationary power source or for other than its intended purpose in this vehicle.

### NOTICE

Avoid fully discharging the high-voltage battery to 0%. The battery will engage a power/torque limiter when the state of charge is low. However, fully discharging the battery to 0% could damage the battery and render the vehicle inoperable. The battery cannot be recharged if it is highly depleted.

There are three different electrical circuits in the system.

- 400V DC high-voltage circuit: Links the battery, charger, inverter and motor, providing energy to the vehicle propulsion system.
- 12V DC circuit: Used to power auxiliaries like the headlights and audio system.
- AC 120 V/ 240 V 60Hz circuit: Used during charging.

The 400V and 12V circuits are linked through the DC-DC converter.

The 400V lithium-ion propulsion battery is comprised of multiple sealed cells that store the energy used to drive the vehicle.

---

During normal operating conditions, the high-voltage propulsion battery also provides charging current through the DC-DC converter to the accessory 12V battery. The 12V may also be charged when the vehicle is connected to a charger.

All batteries degrade over time. The high-voltage battery pack efficiency will vary in function of the service time and condition.

## **Battery Management System (BMS)**

The high-voltage battery pack is equipped with a Battery Management System (BMS) that monitors the condition of the high-voltage propulsion battery. The BMS optimizes charging and under certain conditions, intervenes to prevent damage to the high-voltage propulsion battery. This intervention includes slowing or stopping the flow of charge if necessary.

The BMS also helps regulate the power flow to the high-voltage propulsion battery during operation. If required, it can limit that power as needed.

## **High-Voltage Battery State of Health (SoH)**

The state of health (SoH) refers to the current health condition of the high voltage (HV) battery compared to its initial state when it was new.

The HV battery life span is directly related to its SoH. When the HV battery ages, it gradually loses performance and range.

Using your vehicle with a state of charge between 20% and 80% is optimal.

Charging to 100% once in a while will not accelerate the degradation of the SoH significantly.

To help preserve a good SoH, as you ride, avoid frequent hard accelerations or sustained top speeds.



Using a level 1 (110V or 220V / 16 amp) or slow charger does take longer but is better for your HV battery. The rate at which the electricity is pushed in the HV battery directly impacts its long-term performance. Using a level 2 (220V / 30 Amp) is ideal for quick refills during a trip or while travelling. If you have the time to use a level 1 charger, your HV battery will benefit from less stress.

Maximize the above best practices to gain the most from your HV battery. Chemical degradation cannot be stopped but can be maintained to its lowest speed.

## CHARGING

### WARNING

Do not use a multi-plug adapter or extension cord.

### WARNING

People with medical electric devices, such as a pacemaker or a cardiovascular defibrillator, should consult their physician for recommendations related to electric vehicles and electric vehicle supply equipment (EVSE).

### NOTICE

To prevent dirt and debris from potentially damaging terminals, ensure that the charge port cover and charge compartment door are closed and secured when not charging the vehicle. If the terminals build up debris over time, do not use tools to clean the terminals. Use compressed air, a soft cloth or low-pressure water to clean.

## Charging Port Connection

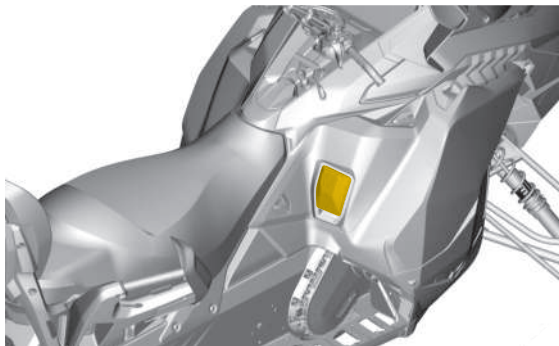

# ELECTRIC VEHICLE (EV) OVERVIEW

The charging connection port is located to the lower right of the driver's view. It is set up to accept both Level 1 or 2 charging. Level 1 charging uses a 120 V AC power source, while Level 2 uses a 240 V AC power source. Level 2 charging is well-suited to quicker charging situations.

## Electric Vehicle Supply Equipment (EVSE)

### WARNING

The vehicle shall only be charged with a CCID (Charge Current Interruption Device According to UL2231) equipped station.

### WARNING

Immediately disconnect the EVSE from the vehicle if plug or wall outlet is hot to the touch or emitting any unusual odors.

### WARNING

Do not use extension cords or adapters with the EVSE.

### WARNING

Do not use the EVSE if the plug does not have a proper connection with the wall outlet or if the wall outlet is rusted or damaged in any way.

### WARNING

Do not use the EVSE if the cable or cord is frayed, has broken insulation or shows any other signs of damage.

The Electric Vehicle Supply Equipment (EVSE) cable used for charging the vehicle must be compatible with a J1772 style port for Level 1 (120V) and Level 2 (240V) charging.

---

## Charging the Vehicle

To charge the high-voltage propulsion battery:

1. Stop the vehicle on a flat surface.
2. Ensure the vehicle is powered OFF.
3. Engage the parking brake.
4. Open the hinged charge port cover.



5. Ensure that the charger socket is free of dirt, debris and water.
6. Insert the EVSE charging plug into the charger socket.

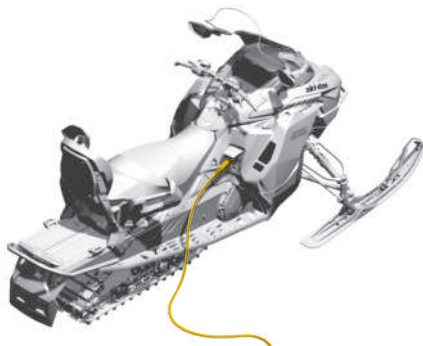

The vehicle display will switch to the charging screen. Charging will continue until the battery is fully charged or the EVSE is disconnected.

## ELECTRIC VEHICLE (EV) OVERVIEW



Though charging will continue until complete, the display will turn off after 30 seconds of inactivity. Touch the screen to resume the display if desired.

### Removing the Charging Cable

To remove the charging cable from the vehicle:

1. Hold down the release button on the charging cable for one second and then remove it from the charging port.

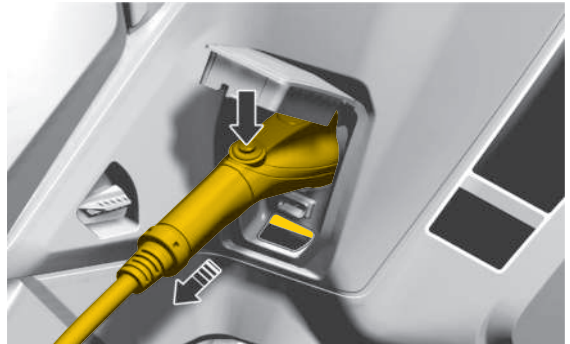

2. Close the charging port cover.

3

---

## Charging Best Practices

### Effect of Temperature

The Ski-Doo Electric snowmobile is designed to thrive in cold environments. For instance, the battery is protected by insulation foam to assist with operation during cold weather. However, there are extremes of temperature to keep in mind. For optimal battery life and long-term performance, whenever possible, avoid exposing the vehicle to ambient temperatures above 40° C (104° F) or below -20° C (-4° F) for extended periods.

Charging in extreme temperatures can limit the rate of charge the high-voltage battery receives. When the battery pack has an internal temperature outside of the appropriate range, the Battery Management System (BMS) intervenes and requires the on-board heater to bring the temperature to the appropriate level. For this to occur, the vehicle must be plugged in with an EVSE to a proper outlet. Charging will resume once the temperature has returned to an appropriate range.

Driving in extreme temperatures can also affect the overall performance and autonomy of the vehicle.

### High-Voltage Battery State of Charge

The vehicle operates best when charged regularly. The high-voltage battery does not need to be fully depleted before charging again. Rather than waiting until the battery charge is low to recharge, take advantage of every opportunity to charge when the vehicle is not in use.

# ELECTRIC VEHICLE (EV) OVERVIEW

## NOTICE

If the high-voltage battery charge is extremely low, it should be plugged in within 24 hours of being discharged to avoid potential damage and preserve its longevity.

State of Charge (SoC) refers to the level, in percentage, at which the HV battery is charged. Ranging from 0 to 100%, the SoC indicates how much energy the HV battery has available.

Using the vehicle with a high voltage battery SoC between 20 and 80% is optimal for it's longevity,

## Ideal Times to Charge

It can be helpful to avoid charging during “peak hours” if possible. Peak hours are those times when electricity demand is the highest across the power grid. Typically, charging at night avoids peak hour times. Charging the vehicle at times like this can help keep charging costs low. Check with your electric company for more information.

## Charging Status and Battery State of Charge

Battery and charging status can be monitored in the instrument cluster.

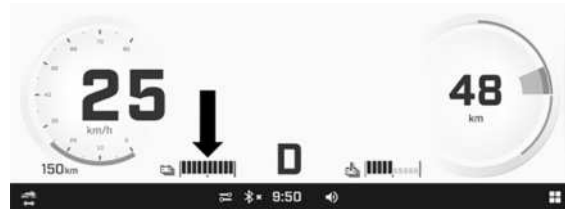

The battery state of charge is shown on the display.



When the state of charge is low, a message is shown on the display.

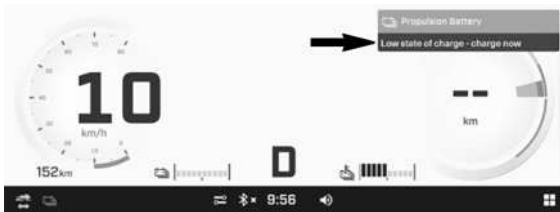

When the vehicle is connected to a charging station, the HV components temperature will be monitored and adjusted using the cooling system. If the HV battery temperature is too cold, a notification will be displayed showing that the system is in warm-up mode. If the HV battery temperature is too high, a notification will appear on the screen, the vehicle will start the cool-down mode and charging will stop. Charging will resume when the optimal charging temperature is reached.

When charging, the HV battery state of charge will be displayed on the left side of the screen, and the estimated remaining charging time on the right side of the screen.



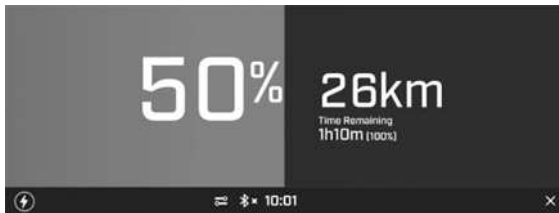

When charging is complete, the estimated time remaining changes to show “Complete.”

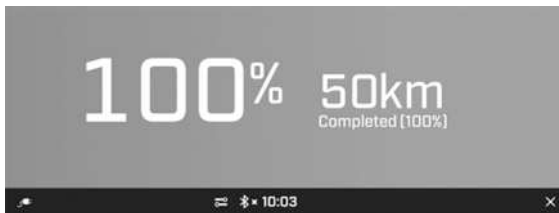

## Power Sources

The following power sources can be used to charge your vehicle:

- 120 V wall outlet
- 240 V wall outlet
- J1772 Level 1 (120V) charging station
- J1772 Level 2 (240V) charging station

### NOTICE

This vehicle is not compatible with Level 3 charging stations or DC fast charge stations.

Be aware that different power sources vary in their effect on charging time.

---

## STARTING AND DRIVING

### Starting the Vehicle

To start the vehicle:

1. Insert the D.E.S.S. key into the D.E.S.S. post.  
The touchscreen will activate when the D.E.S.S. is recognized by the system.

2. Pull the emergency stop switch up.



# ELECTRIC VEHICLE (EV) OVERVIEW

3. Press the Start button on the handlebar multifunction switch for 0.5 seconds. The ON indicator is shown on the lower left of the display.

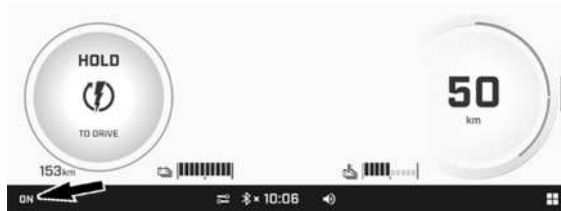

4. Press the Start button for 0.5 seconds again to activate the high-voltage propulsion system drive mode.
5. When the  indicator is shown in the lower left of the display, the accelerator lever can then be used to drive forward.

## Switching to and from Reverse

When the  icon is lit, it is automatically set to the forward drive position.

To switch to reverse mode, press and hold the Start button for 0.5 seconds. Repeat the procedure to return to forward drive mode.

## Standby Mode

When the  icon is lit, it will begin moving when the accelerator lever is activated. While in this mode, if there is no interaction with the vehicle for one minute, a tone will sound, and a message will be displayed.

Pressing the brake lever will keep the vehicle ready to drive.

If there is still no user interaction, the vehicle will automatically switch to the ON mode, where movement is not possible.

3

While in the ON mode, a message will be displayed after 5 minutes without interaction, indicating to the user to activate the brake lever to keep the vehicle awake. If there is still no interaction, the vehicle will shut down.

## Regenerative Braking

Regenerative braking captures some of the excess energy released in the braking process and returns it to the high-voltage system for increased range, when possible. It is automatically activated when releasing the accelerator lever and increases when the brake lever is pulled.



The amount of regenerative braking that is occurring can be monitored in this area of the power meter.

## Performance Gauge



- A. Vehicle range
- B. Current performance
- C. Discharge limit
- D. Regenerative braking limit

The performance gauge is located on the right side of the touchscreen display.

The range is displayed at the center of the gauge. It adjusts automatically depending on usage and operating conditions.

The thick curve, which varies instantaneously on both the discharge and regenerative braking portions, represents the actual usage of the vehicle's powertrain. The outer thin lines indicate the maximum available performance, which may be influenced by factors such as the propulsion battery state of charge, the powertrain components' temperature and the key type. Any limitation will cause them to be partially shaded.

### Vehicle Range

This vehicle is designed for short trips of up to 50 km (31 miles), when equipped with the shorter track and up to 30 km (18.6 miles), when equipped with the longer track. A variety of factors can influence the vehicle's range and the time until charging is needed, including:

- **Weather:** In addition to temperature, slippery conditions and strong headwinds can adversely affect driving range and performance.
- **Terrain:** Rough terrain or frequent and difficult hill climbs require more power from the vehicle, thus affecting range.
- **Payload:** A passenger and cargo increase demand on the vehicle.
- **Towing:** Towing increase demand on the vehicle.
- **Style of Driving:** An aggressive or high-speed driving style utilizes more power than a conservative driving style. An average speed of 25 km/h (15 mph) is within the optimal range.
- **Starting and Stopping:** It takes more energy to accelerate to a cruising speed than it does to maintain the same speed.
- **Accessories:** Additional accessories can add weight and energy draw.

---

Data from previous trips, such as performance and driving style, is used for calculating vehicle range.

## Turning OFF the Vehicle

To turn off the vehicle:

1. Ensure that the vehicle has come to a complete stop.
2. Apply the parking brake.

3. Push the Stop switch down to the OFF position.



4. Remove the D.E.S.S. from the post.

### DIFFERENCES BETWEEN ELECTRIC VEHICLES AND VEHICLES WITH INTERNAL COMBUSTION ENGINES

This electric vehicle is designed to provide the same features and versatility of a snowmobile with an internal combustion engine. Beyond the difference in power source (electricity vs. gasoline), there are other differences you will notice with an EV.

- **Gauges:** The speedometer will be familiar when compared to a traditional vehicle. However, in place of a tachometer that measures RPM, this vehicle has a performance gauge that measures power output, regenerative braking and vehicle range.
- **Sound:** Under normal operating conditions, an EV generates significantly less sound than a vehicle with an internal combustion engine.

#### CAUTION

**Be aware that the vehicle can be in Drive without producing sound. Always check to ensure the vehicle state.**

- **Vibration:** An EV does not produce as much vibration during operation as an internal combustion engine.
- **Emissions:** An EV does not produce emissions from the vehicle when it operates.
- **Components:** The EV-specific components covered in this chapter (high-voltage propulsion battery, inverter, electric motor) are different than what would be found on an internal combustion engine. Conversely, components like mufflers, spark plugs and air intakes are not needed on EVs.





## 4 VEHICLE INFORMATION - TABLE OF CONTENTS

### VEHICLE DEACTIVATION

#### CLASSIFICATION .....4-3

EV 00 – No Deactivation – Category  
Description ..... 4-3

EV 00 – No Deactivation – Safe Working  
Procedures ..... 4-5

EV 01 – Basic Deactivation – Category  
Description ..... 4-8

EV 01 – Basic Deactivation – Safe Working  
Procedures ..... 4-10

#### PRIMARY CONTROLS ..... 4-14

Handlebar ..... 4-14

Accelerator Lever ..... 4-15

Emergency Stop Switch ..... 4-18

Brake Lever ..... 4-19

Parking Brake Lever ..... 4-24

Vehicle Cut-Off Switch ..... 4-26

#### SECONDARY CONTROLS ..... 4-28

Handlebar Multifunction Switch ..... 4-29

Passenger Heated Grip Switch (If  
equipped) ..... 4-31

#### BODY AND SEAT ..... 4-33

Front and Rear Bumpers ..... 4-33

Windshield ..... 4-35

Adjustable Mirrors (if equipped) ..... 4-38

Front Storage Compartment ..... 4-39

Side Panels ..... 4-40

Upper Body Module ..... 4-42

Seat ..... 4-46

#### EQUIPMENT ..... 4-50

Operator's Guide ..... 4-50

Heated Cellphone Case (if  
equipped) ..... 4-50

Power Outlet - USB ..... 4-50

## **4 VEHICLE INFORMATION - TABLE OF CONTENTS**

---

Adjustable Handlebar Riser (if equipped) . . . . .	4-51	<b>RIDING CONDITIONS AND YOUR SNOWMOBILE . . . . .</b>	<b>4-78</b>
Heated Visor Connector (if equipped) . . . . .	4-52	Hard Packed Snow . . . . .	4-78
Tools . . . . .	4-52	<b>TUNE YOUR RIDE . . . . .</b>	<b>4-80</b>
<b>MULTIFUNCTION DISPLAY . . . . .</b>	<b>4-55</b>	Front Suspension Adjustments . . . . .	4-82
Default Display . . . . .	4-55	Rear Suspension Adjustments . . . . .	4-83
Navigating the Multifunction Display . . . . .	4-55	Adjustment Tips According to Vehicle Behavior . . . . .	4-85
Full View Display . . . . .	4-56		
Narrow View Display . . . . .	4-58		
Applet Menu . . . . .	4-59		
Quick Preferences . . . . .	4-69		
Warning Lamps and Indicators . . . . .	4-70		
Pairing your Smartphone via Bluetooth . . . . .	4-73		
Messages in Multifunction Display . . . . .	4-74		
BRP GO! App . . . . .	4-75		
Quick Tour of the BRP GO! App . . . . .	4-76		

## VEHICLE DEACTIVATION CLASSIFICATION

The maintenance and repair tasks for this vehicle are classified using a deactivation level for the vehicle high-voltage components. Tasks in this guide are identified as either EV-00 or EV-01. That designation can be found at the beginning of each applicable procedure.



**WARNING**

Do not use a lower deactivation category than described. Failure to do so could result in serious injury or death.

4

### EV 00 – No Deactivation – Category Description



Indicates a maintenance or repair task requiring no deactivation of the vehicle high-voltage components.

#### Vehicle High-Voltage Battery State: Active

The vehicle is functional and the powertrain can be activated or deactivated using the stop switch.

---

### **Example of tasks to be performed:**

- BUDS scan & updates.
- Systems functional tests using BUDS.
- Snowmobile track tension adjustment.

### **Tasks Limitations**

Must not interact with the transmission components and/or propulsion system components:

- Sprocket
- Track<sup>(1)</sup>
- Etc.

Or at any time the high-voltage components:

- High-Voltage Battery
- High-Voltage Charger
- High-Voltage E-Motor
- High-Voltage Inverter
- High-Voltage Cables

**(1) Only the track tension adjustment can be performed using appropriate safety precautions.**



Do not disconnect or touch any exposed connections and/or damaged components with bare fingers, non-insulated tools or other metallic objects. Contact with high-voltage current will cause serious injury or death.

## Expectations

BUDS connection needs active 12V and vehicle key installed. Powertrain must not be activated accidentally. Stop switch in OFF position is the safety feature used.

4

## EV 00 – No Deactivation – Safe Working Procedures



### Mandatory Personal Protective Equipment (PPE):

- Safety glasses
- Safety shoes with electric shock resistant soles

### Required Tools:

- None

## Vehicle Preparation

1. Disconnect the charging cable from the vehicle charging port, if applicable.

### *On vehicle equipped with Type 1 Connector (SAE J1772)*

- Press on the handle release button, wait for 1 second and pull on the handle.

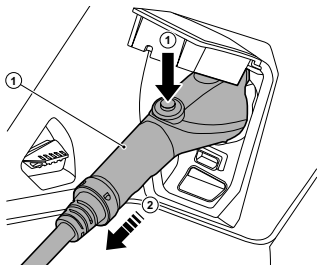

### **Electric Snowmobile — Typical**

1. Charging cable

2. Secure the vehicle on the work table, if applicable.



Make sure to elevate all moving components so they are not in contact with the work table when servicing.

3. Apply the parking brake, if applicable.

4. Press the stop switch in the **OFF** position.

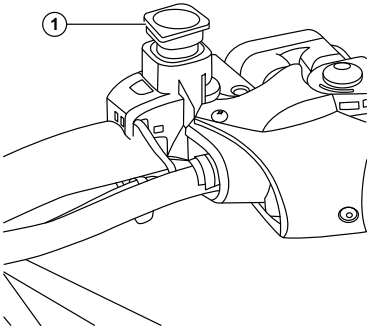

### Electric Snowmobile - Typical

#### 1. Stop switch

### Vehicle Release

1. Remove the vehicle from the work table and place on the ground, if applicable.
2. Release the parking brake, if applicable.

---

## EV 01 – Basic Deactivation – Category Description



Indicates a task requiring a basic deactivation of the vehicle high-voltage components.

### **Vehicle High-Voltage Battery State: Deactivated / Single Lockout**

The vehicle is secured on a work table, where possible, and the following requirements are met:

- The parking brake is applied (if possible).
- The stop switch in the OFF position.
- On vehicle with DESS post, the DESS key is removed and the DESS locking device is installed. (If applicable)

### **Example of tasks to be performed:**

- Designated maintenance tasks, refer to the vehicle maintenance schedule chart.
- Body component replacement, excluding chassis.



## Tasks Limitations

Must not interact with the transmission components:

- Sprocket
- Track
- Etc.

Or at any time with the high-voltage components:

- High-Voltage Battery
- High-Voltage Charger
- High-Voltage E-Motor
- High-Voltage Inverter
- High-Voltage Cables



**DANGER**

Do not disconnect or touch any exposed connections and/or damaged components with bare fingers, non-insulated tools or other metallic objects. Contact with high-voltage current will cause serious injury or death.

## Expectations

The vehicle cannot be activated, allowing basic work to be done with the vehicle in OFF state.

---

## EV 01 – Basic Deactivation – Safe Working Procedures



### **Mandatory Personal Protective Equipment (PPE):**

- Safety glasses
- Safety shoes with electric shock resistant soles

### **Mandatory Tools:**

BRP special tools:

- DESS locking device (Refer to Service Manual for part numbers)

Commercially available tools:

- Safety lock box
- 1 Personal padlock

### Vehicle Preparation

1. Disconnect the charging cable from the vehicle charging port, if applicable.

#### ***On vehicle equipped with Type 1 Connector (SAE J1772)***

- Press on the handle release button, wait for 1 second and pull on the handle.

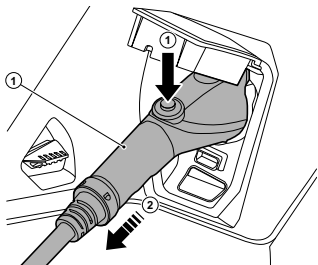

#### **Electric Snowmobile — Typical**

1. Charging cable

2. Secure the vehicle on the work table, if applicable.



Make sure to elevate all moving components so they are not in contact with the work table when servicing.

3. Apply the parking brake, if applicable.

- 
4. Press the stop switch in the **OFF** position.

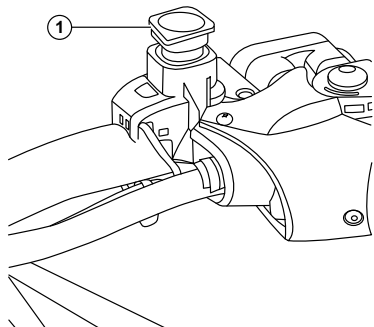

### Electric Snowmobile - Typical

1. Stop switch

Proceed with the appropriate *Deactivation Procedure*.

### Basic Deactivation Procedure

1. Remove the vehicle key from the vehicle.
2. For models with DESS key, install and lock the DESS locking device.

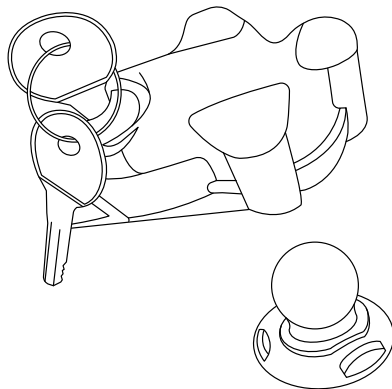

3. Place in the safety lock box:
  - Vehicle key
  - DESS locking device key, if applicable.
4. Lock the safety lock box with the worker's personal padlock.

Proceed with the tasks permitted under this deactivation level.

### IMPORTANT

The single key of the worker's personal lock on the safety lock box must remain on the EV technician working on the unit until activation is safe to perform.

### Basic Activation Procedure

Once tasks are completed and the vehicle is safe to be activated proceed as follow:

1. Disconnect the charging cable from the charging port, if applicable.

2. Unlock the safety lock box.
3. Retrieve from the safety lock box:
  - Vehicle key
  - DESS locking device key, if applicable.
4. Start the vehicle. Refer to *Starting the Vehicle* in the operator's guide.

### Vehicle Release

1. Remove the vehicle from the work table, if applicable:
2. Place the vehicle on the ground.
3. Release the parking brake, if applicable.

---

## PRIMARY CONTROLS

### Handlebar

The handlebar controls the steering of the snowmobile. As the handlebar is rotated to right or left, the skis are turned right or left to steer the snowmobile.



Fast reverse while turning, could result in loss of stability and control.

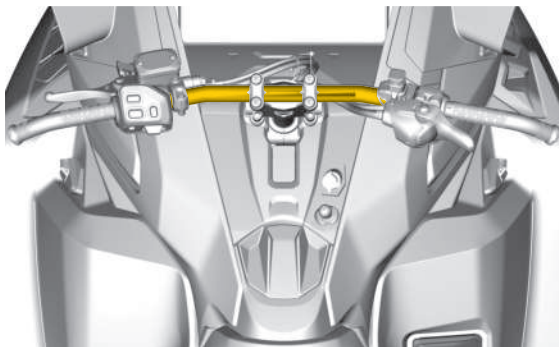

**Typical**

## Accelerator Lever

The accelerator lever is located on the RH side of handlebar.

When squeezed, it increases the vehicle speed. When released, the vehicle speed returns automatically to the ready to drive mode.

After 60 seconds of inactivity, the vehicle will beep and drive mode will be deactivated.

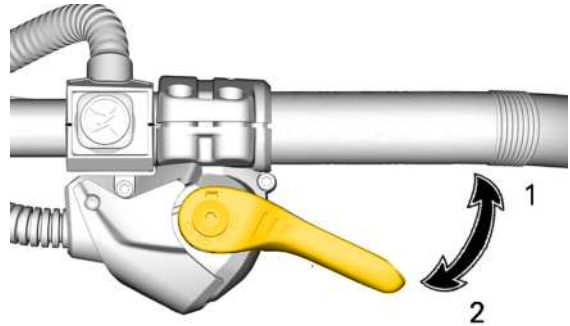

### iTC Accelerator Lever

1. To accelerate
2. To decelerate

#### WARNING

Test the accelerator lever operation each time before starting the vehicle. The lever must return to the rest position once released. Otherwise, do not start the vehicle.

## Switching from Thumb to Finger Accelerator Lever Position (iTC Accelerator Lever)

Vehicle Deactivation Level:	
-----------------------------	---

See *Vehicle Deactivation Classification* for more information.

### CAUTION

It is highly recommended to immobilize the snowmobile and ensure that the emergency stop switch is engaged before attempting any modification to the accelerator lever position as it could lead to a hazardous situation.

There are three positions to choose from when going from the thumb to the finger accelerator position and the best one will be to the rider's preference and in direct relation with the riding style and conditions.

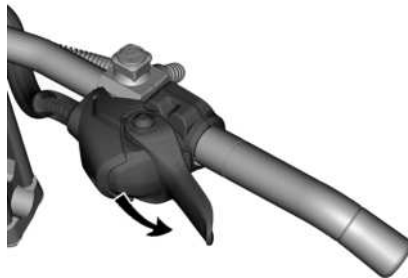

**Thumb accelerator position : push downward to rotate accelerator housing**



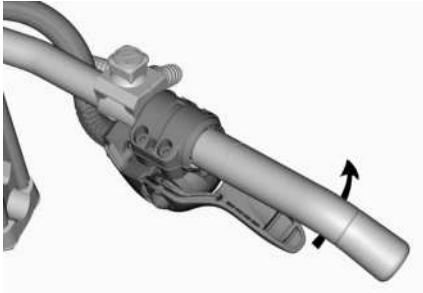

If wanted, continue to rotate the accelerator housing



Finger accelerator position

**⚠ CAUTION**

It is **HIGHLY** recommended to use gloves and **NOT** mitts when using the finger accelerator lever position.  
It is not recommended to use the finger accelerator lever position while riding in dense off-trail areas.

The procedure to go back to the thumb accelerator lever position is the reverse of the one shown above.

## Emergency Stop Switch

The emergency stop switch is located on the RH side of handlebar.

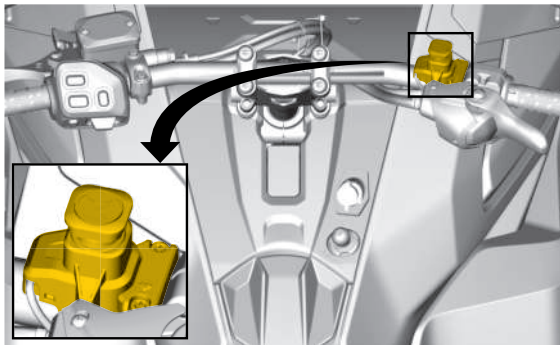

Typical

To stop the vehicle in an emergency, push the switch down to the OFF position and simultaneously apply the brake.



OFF position

To allow the drive mode activation, pull the switch up to the ON position.



**on position**

All operators of the snowmobile should familiarize themselves with the function of the emergency stop switch by using it several times on first outing and whenever stopping the vehicle thereafter. This vehicle stopping procedure will become a reflex and will prepare operators for emergency situations requiring its use.

### **WARNING**

If the switch has been used in an emergency caused by a suspected malfunction, the source of the malfunction should be determined and corrected before activating the vehicle. Visit an authorized BRP snowmobile dealer for servicing.

### **Brake Lever**

The brake lever is located on the LH side of handlebar.

---

When brought toward the grip, the brake is applied. When released, it automatically returns to the rest position. Braking effect is proportional to the force applied on the lever and to the type of terrain and its snow coverage.

Most effective braking is done without locking the track.

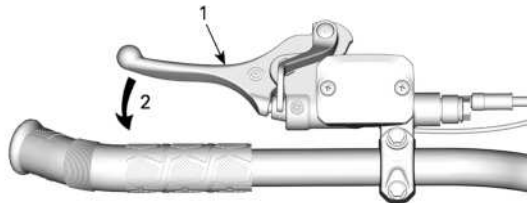

**typical**

- 1. Brake lever
- 2. To apply the brake

### Brake Lever Adjustment

Vehicle Deactivation Level:	
-----------------------------	---

See *Vehicle Deactivation Classification* for more information.



**WARNING**

It is important to adjust the brake lever to the user size and normal riding position.

Proper brake lever position should allow:

- Good support for the index and middle finger on the lever.
- Use the outer end of the lever to optimize the force.
- Proper wrist alignment.

Taking the time to adjust and try out the brake lever before your first snowmobile outing improves user comfort.

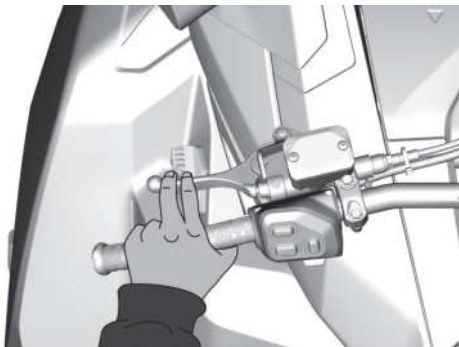

## Adjusting the Brake Lever

Vehicle Deactivation  
Level:



See *Vehicle Deactivation Classification* for more information.

1. Loosen the two bolts enough to easily move the brake lever on the handlebar.

### NOTE:

If the two bolts are not loosened enough, the brake lever can leave marks on the handlebar.

2. Locate the reference mark on the handlebar and respect the distance and rotation limits.

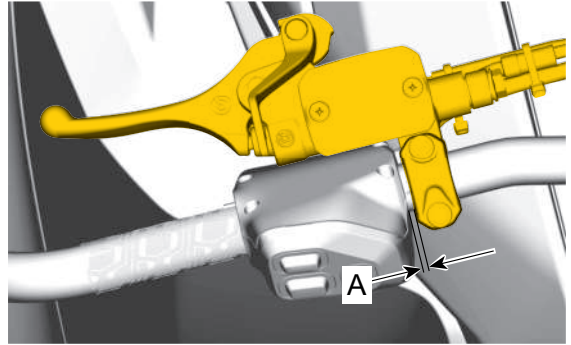
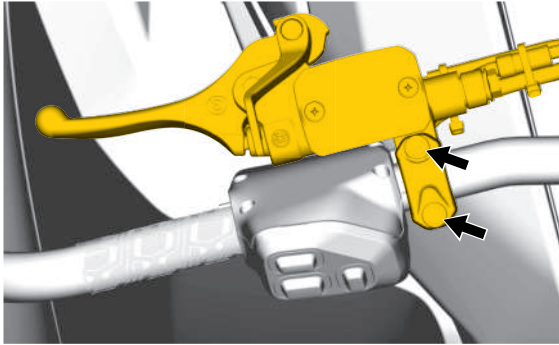

*A. 0 to 5 mm (0 to 0.197 in) between the handlebar point and side of the brake lever*

3. With the operator on the driver seat, put the brake lever in the desired position.
4. Tighten the two bolts to specification.

<b>TIGHTENING TORQUE</b>	
Brake lever adjustment bolts	$8.5 \pm 1.5$ Nm ( $75 \pm 13$ lbf-in)

## Parking Brake Lever

The parking brake lever is located on the LH side of handlebar.

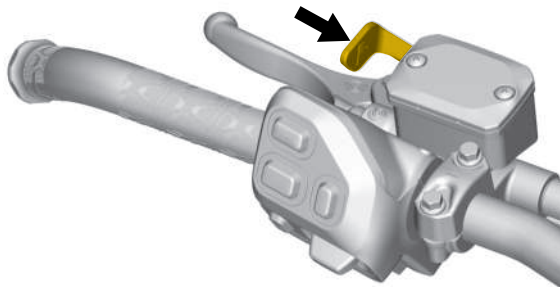

### Typical

The parking brake should be used whenever the snowmobile is parked.



 **WARNING**

Make sure the parking brake is fully disengaged before operating the snowmobile. When you ride the vehicle, brake pads that are caused to drag by a continuous pressure on the lever may cause damage to the brake system and cause loss of braking capacity and/or fire.

### To Engage the Parking Brake

Apply and hold the brake, then lock the brake lever using the parking brake lever as shown.

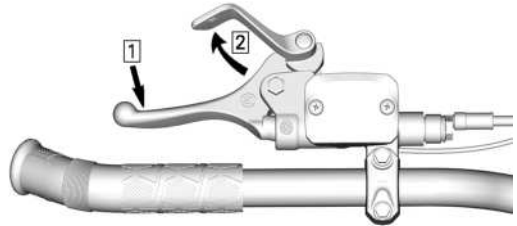

#### Typical — Engage the Mechanism

1. Apply and hold the brake
2. Lock the brake lever using the parking brake lever

## To Release the Parking Brake

Activate the brake lever. The parking brake lever will automatically return to its original position. Always release the parking brake before riding.

## Vehicle Cut-Off Switch

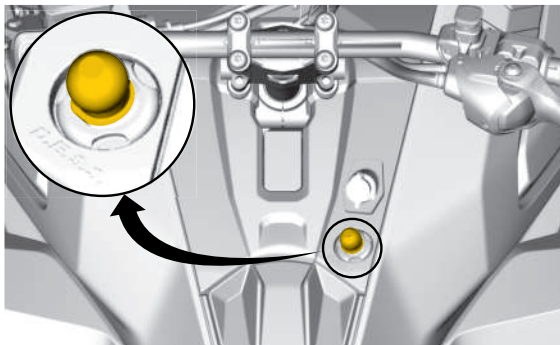

Typical

The vehicle cut-off switch (tether cord) is located on the console.

The tether cord cap must be securely snapped on the vehicle cut-off switch to allow vehicle operation.

Pulling the tether cord cap from the switch shuts the vehicle off.

### WARNING

Always attach the tether cord eyelet to clothing before starting the vehicle.

## D.E.S.S. (Digitally Encoded Security System)

The tether cord cap has an integrated D.E.S.S. key to provide you and your snowmobile with the equivalent security of a conventional lock key.

The D.E.S.S. key contains an electronic chip which features a unique permanently memorized digital code.

Your authorized BRP snowmobile dealer has programmed the D. E. S. S. of your snowmobile to recognize the D.E.S.S. key in the tether cord cap to allow vehicle operation.

If another tether cord is used without programming the D.E.S.S., the vehicle will start but will not allow the high-voltage propulsion system activation.

Two D. E. S. S. keys are provided with the vehicle. One is a Learning key, with lower torque and a limited top speed of 40 km/h (25 mph). The other is the normal key, allowing for a higher top speed of 60 km/h (37 mph).

Make sure the tether cord cap is free of dirt or snow.

### **D.E.S.S. Flexibility**

The D. E. S. S. of your snowmobile can be programmed by your authorized BRP snowmobile dealer to accept up to 8 different keys.

We recommend the purchase of additional tether cords from your authorized BRP snowmobile dealer. If you have more than one D.E.S.S. equipped BRP snowmobile, each can be programmed by your authorized BRP snowmobile dealer to accept the other vehicles D.E.S.S. keys.

---

## **SECONDARY CONTROLS**

Some features may not apply to your model or could be optional.

Vehicle safety labels are not shown on illustrations. For information on vehicle safety labels, refer to *Vehicle Safety Labels*.

## Handlebar Multifunction Switch

Multifunction switch is located on the LH side of handlebar.



## Models with the 10.25" Color Touchscreen Display

1. *Headlights dimmer button*
2. *Ride settings button*
3. *Heated throttle lever and grips button*
4. *Applet Switcher button*
5. *Push To Talk (PTT) button*
6. *Up / Down / OK button*
7. *Start button*

## Headlights Dimmer Button

Press to select HIGH or LOW beam. Lights are automatically ON when the vehicle is in Forward (Drive) or Reverse.

## Ride Setting Button

This button is used to change the following:

- Volume
- Heated grips and accelerator lever intensity (when added to ride setting menu).

## Heated Grips and Accelerator Lever Button

NOTE:

If the voltage of the 12V battery falls below 12 V, the heated grips will be turned off.

Press the button to select between the grip and the thumb and use the up/down button as required to adjust the heating intensity to keep your hands at a comfortable temperature.

The heating intensity is displayed in the digital display. Refer to the display section.

## Adjusting the Heated Grips and Thumb – 10.25” Color Touchscreen Display

1. Pressing the heated grip button will add one level of heating.
2. Use the UP and DOWN buttons to adjust the heated grips.
3. Pressing the heated grip button a second time will adjust the heated thumb in the same manner as the heated grip.
4. Use the UP and DOWN buttons to adjust the heated thumb.

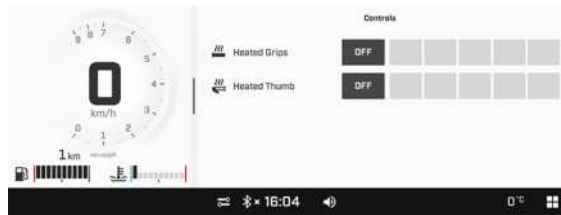

### Applet Switcher Button

This button is used to show the various applets in the display.

### Microphone Button

This button is used to activate the voice commands.

### UP / Down / OK Button

This button is used to navigate and select the various menus of the multifunction display.

### Start Button

Press to start the vehicle. Refer to *STARTING THE VEHICLE* in *STARTING AND DRIVING*.

### Passenger Heated Grip Switch (If equipped)

The switch is located on the LH passenger handhold.



Adjust the heating intensity as shown.

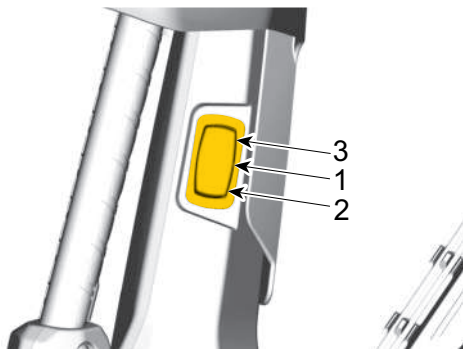

1. *Off*
2. *Warm*
3. *Hot*



### **BODY AND SEAT**

#### **Front and Rear Bumpers**

To be used whenever snowmobile requires manual lifting.

**⚠ CAUTION**

Beware of injuries by using proper lifting techniques, including lifting with your legs. Do not attempt to lift the rear of vehicle if it is above your limits. Use appropriate lifting device or have assistance to share the lifting stress if possible.

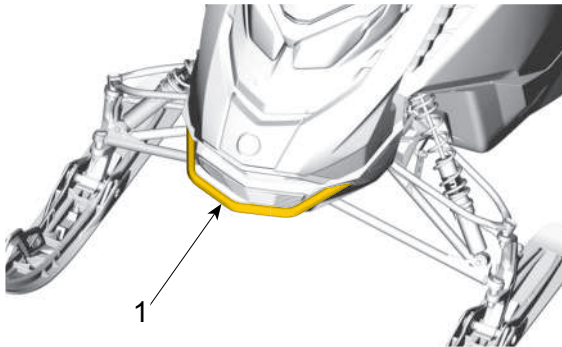

**typical**

*1. Front bumper*

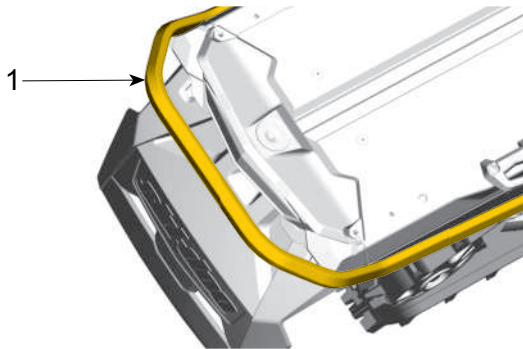

**typical**

*1. Rear bumper*

## NOTICE

The Grand Touring vehicle is not designed for towing. The Expedition can tow only when properly equipped with an accessory HD rear bumper.

## NOTICE

Do not use skis to pull or lift the snowmobile.

## Windshield

Windshield type depends on vehicle model selection. Some windshields may be equipped with deflectors and/or mirrors.

## Removing the Windshield

Vehicle Deactivation  
Level:



Refer to *Vehicle Deactivation Classification* for more information.

1. Place hands on each side of the windshield.

- 
2. Pull the windshield up until both side pins come out of their rubber grommet.



**Typical - Windshield with deflectors shown**

3. Pull up until both middle pins come out of their rubber grommet.

4. Disengage the center pin or tab.

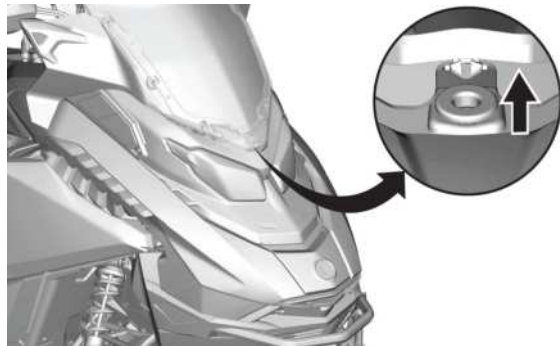

**Typical - Windshield with deflectors shown**

### Installing the Windshield

Vehicle Deactivation  
Level:



Refer to *Vehicle Deactivation Classification* for more information.

1. Lubricate the grommets using soapsuds, if required.

#### NOTICE

Do not lubricate grommets with any type of grease.

2. Insert center pin or tab in headlamp module hole.

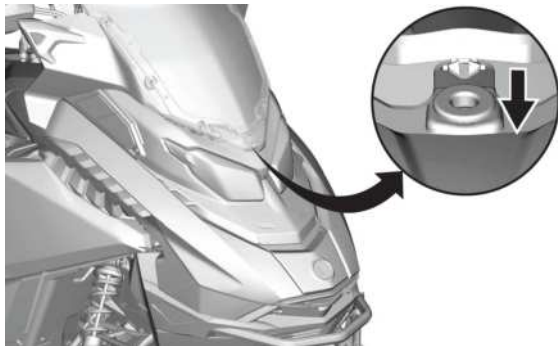

Typical - Windshield with deflectors shown

3. Secure windshield by inserting the windshield pins into the grommets.



Typical - Windshield with deflectors shown

### Adjustable Mirrors (if equipped)

Each mirror can be adjusted to suit the operator's preference.

 **WARNING**

Adjust with the vehicle at rest in a safe place.

When installing a cover, the mirrors can be tilted downward to ease the installation.

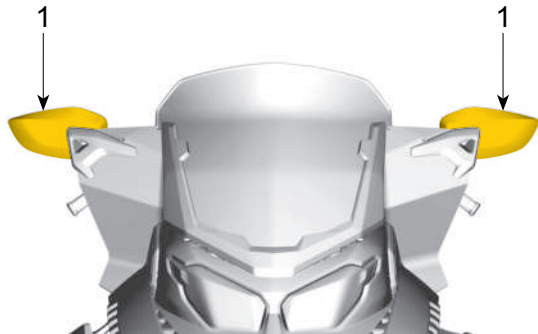

Typical

To open, push the button and lift the cover.

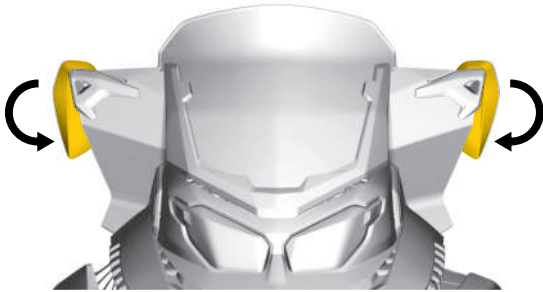

Typical

### Front Storage Compartment

A storage compartment is located at the front of the vehicle, above the gauge.

The Operator's Guide is in the front storage compartment.

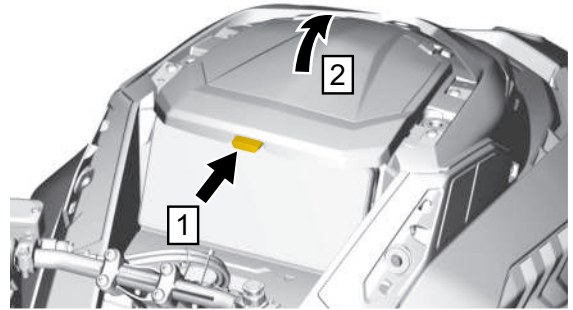

Typical

NOTE:

When closing, make sure the cover is secured properly. You will hear a "click."

## Side Panels

Vehicle Deactivation  
Level:



See *Vehicle Deactivation Classification* for more information.

 **WARNING**

Never operate the vehicle with side panels opened or removed.

## Removing the Side Panels

1. Unlock all latches, then open the panel.

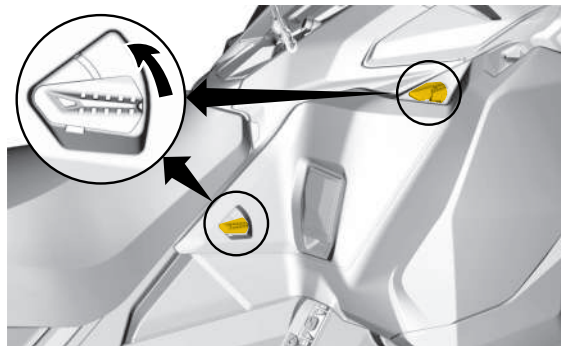

**Typical — 2 Latches**



2. Pivot the side panel around its lower edge.

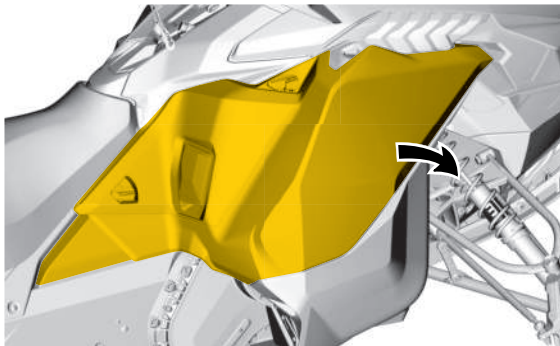

3. Slide the panel hinge off the bottom pan.

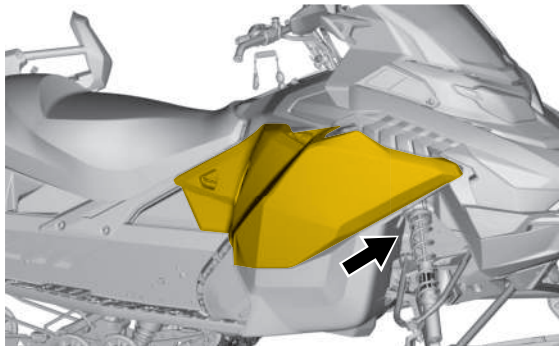

### NOTICE

Make sure to place the panel in a safe place to avoid scratching it.

---

## Installing the Side Panels

Vehicle Deactivation Level:	
--------------------------------	---

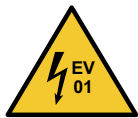

Refer to *Vehicle Deactivation Classification* for more information.

The installation is the reverse of the removal procedure. Make sure the bottom panel tab is inserted in the side bottom pan during installation. If not, the side bottom pan will be scratched and the panel tab can get damaged.

## Upper Body Module

### Removing the Upper Body Module

Vehicle Deactivation Level:	
--------------------------------	---

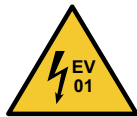

Refer to *Vehicle Deactivation Classification* for more information.

1. Remove both side panels. Refer to *Side Panels* in this section.

2. Remove the access cover by sliding it rearward.

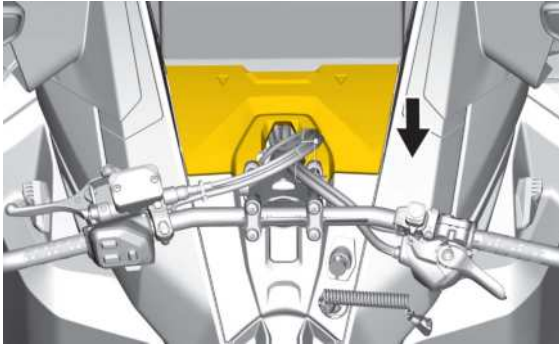

3. Disconnect the following connectors.

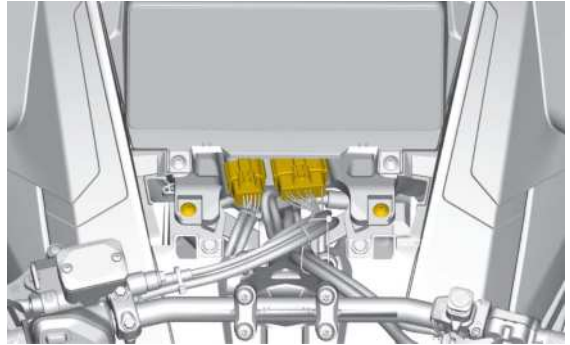

4

- 
4. Remove the upper body module retaining screws on both sides.

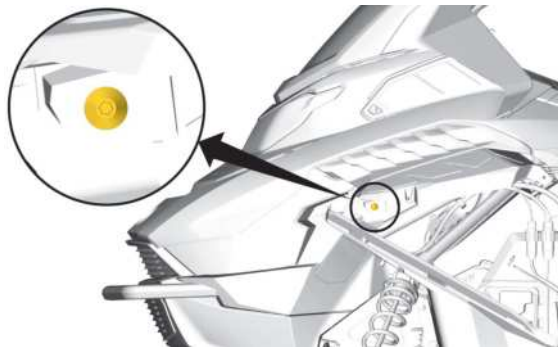
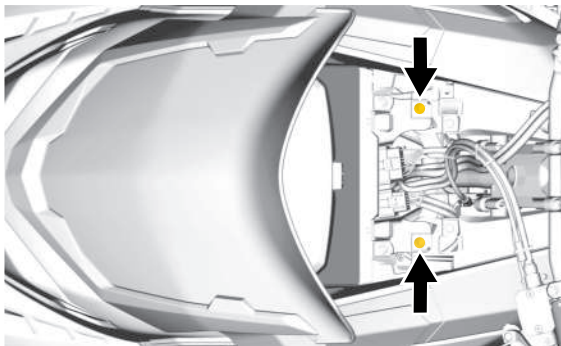

5. Grab the upper body module in the gauge support area.
6. Pull the module forward.
7. Remove the module from the vehicle.

### Installing the Upper Body Module

Vehicle Deactivation  
Level:



Refer to *Vehicle Deactivation Classification* for more information.

1. At front, insert the upper body module tabs into the bottom pan openings.

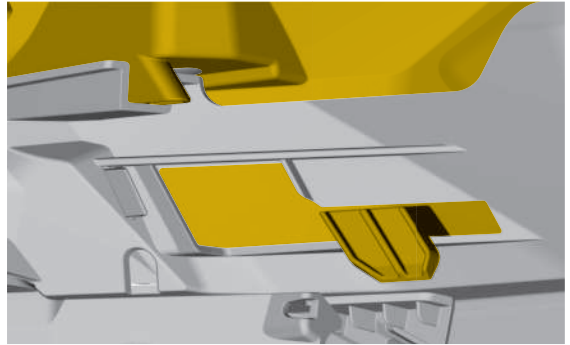

**Front Hood Tab**

2. Lower the rear end of the upper body module.
3. Insert the rear end hooks of the upper body module into the slots in the console.

4. On both sides, install the upper body module retaining screws.

<b>TIGHTENING TORQUE</b>	
Upper body screws	1.8 ± 0.2 Nm (16 ± 2 lbf-in)

5. Connect the headlight connectors.
6. Install the storage compartment but leave the cover open.
7. Install the gauge, secure with the screws.

<b>TIGHTENING TORQUE</b>	
Gauge support screws	2.3 ± 0.2 Nm (20 ± 2 lbf-in)

## Seat

Vehicle Deactivation Level:	
-----------------------------	---

See *Vehicle Deactivation Classification* for more information.

## Removing the Seat

Vehicle Deactivation Level:	
-----------------------------	---

Refer to *Vehicle Deactivation Classification* for more information.

1. Unlock seat

1. Push the center of the seat forward.
  2. Pull on both sides to disengage the ball studs.
2. Remove the seat.

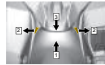

1. Push

2. Pull

3. Lift up and backward to unlock seat

### Installing the Seat

Vehicle Deactivation  
Level:

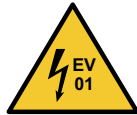

Refer to *Vehicle Deactivation Classification* for more information.

1. Place seat over the hooks, then slide it forward.

2. Engage both ball studs at front.

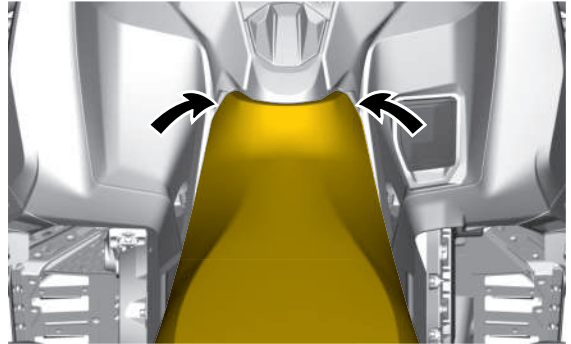

 **WARNING**

Make sure the seat is securely latched before riding.

## Passenger Handholds (if equipped)

The passenger handholds provide a strong holding point and comfort for the passenger on long rides.

### Adjusting the Passenger Handholds

Vehicle Deactivation Level:	
-----------------------------	---

Refer to *Vehicle Deactivation Classification* for more information.

To adjust the handhold height, proceed as follows:

1. Remove the screws.

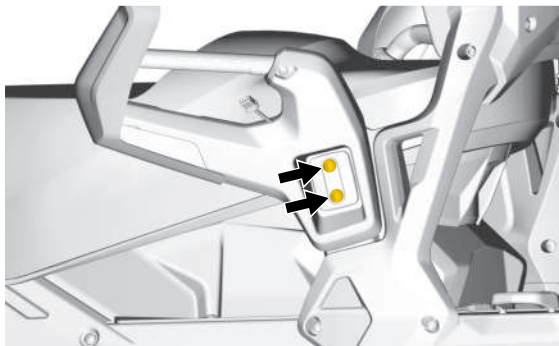



2. Raise or lower the handhold to suit the passenger's comfort.

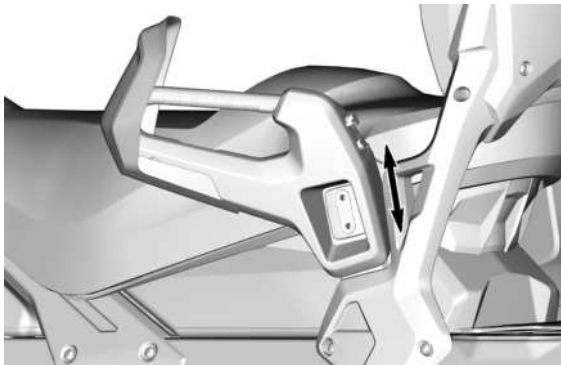

3. Reinstall the screws. Tighten to specification.

<i>Tightening Torque</i>	
Handhold screw	$24.5 \pm 3.5$ Nm ( $18 \pm 3$ lbf-ft)

---

## EQUIPMENT

Some features may not apply to your model or could be optional.

### Operator's Guide

The Operator's Guide should be stored in the *Front Storage Compartment*.

### Heated Cellphone Case (if equipped)

A heated cellphone case is mounted underneath the front storage compartment cover. It allows you to keep your cellphone at a warm temperature while charging.

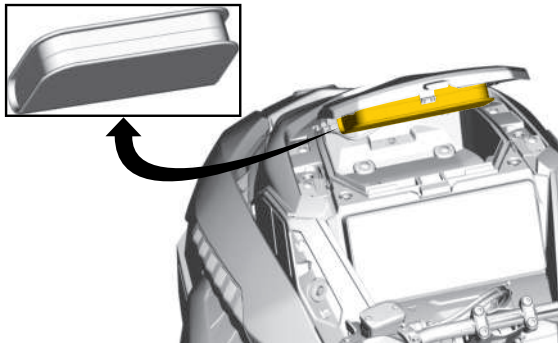

### Power Outlet - USB

The USB power outlet is located in the front storage compartment. It allows you to charge your cellphone while stored in the heated cell case.

The handlebar can be set in four different positions.

To change the handlebar position, pull the lever and position the handlebar as desired.

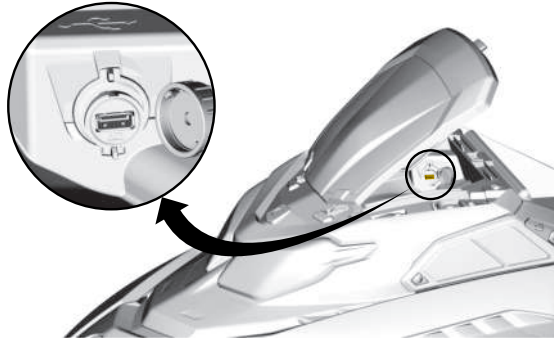
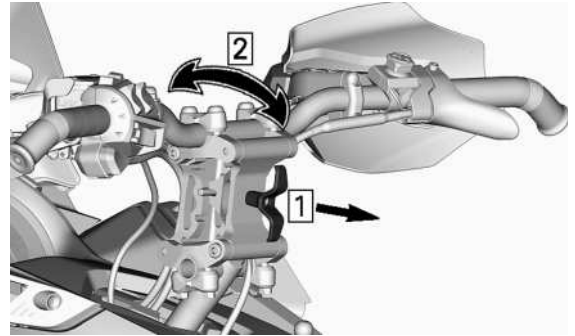

### Adjustable Handlebar Riser (if equipped)



Always stop the vehicle before adjusting the handlebar.

---

## Heated Visor Connector (if equipped)

An electric visor can be connected to the heated visor connector. A stress relief extension is supplied with the vehicle.



**Heated Visor Connector location**

## Tools

A part of the compartment under the operator seat is designed to hold the tools allowing for basic maintenance.

The tools are supplied with the vehicle. They should always be installed in their proper location and orientation.

Install in the following sequence:

1. Slide the suspension adjustment tool open end under the retaining tab.

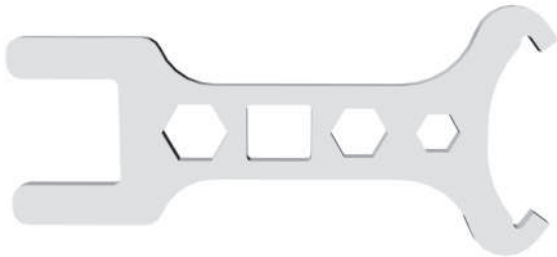

**Suspension adjustment tool**

2. Press the closed end on the retaining tabs.



4

- 
3. Slide the headlight adjustment tool short end into the hole.

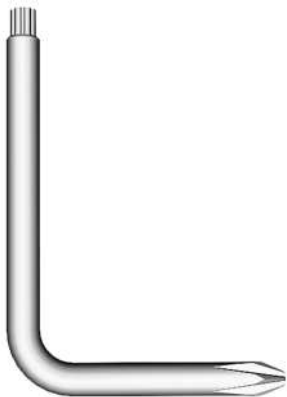

**Headlight adjustment tool**

4. Rotate and clip the long end in place.

## MULTIFUNCTION DISPLAY

### Default Display

#### Light Mode

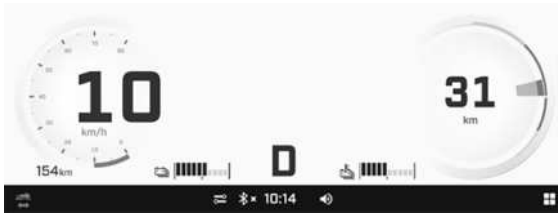

#### Dark Mode

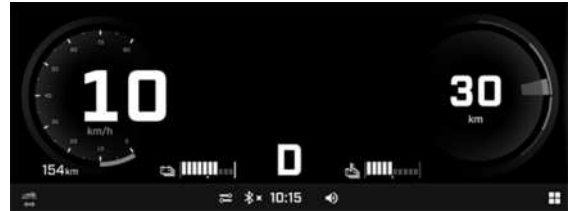

4

### Navigating the Multifunction Display

#### WARNING

Reading or operating the multifunction display can distract you from the operation of the vehicle, particularly from constantly scanning the environment. Always pay attention to road conditions and ensure your environment is clear and free from obstacles. Furthermore, when riding, only glance at the multifunction display briefly to maintain awareness of road conditions.

---

The instrument cluster includes digital gauges (speedometer and performance gauge), tell-tales, indicators, controls and an infotainment center with a digital touchscreen.

We recommend you practice selecting some functions on the infotainment center before getting on the road. You will get used to them and they will be easier to use while riding.

Use the handlebar multifunction switch to navigate (touchscreen not available when riding). Refer to *Secondary Controls*.

Pressing the applet switcher button on the handlebar multifunction switch will make the selected mode appear on top of the cluster.

## Full View Display

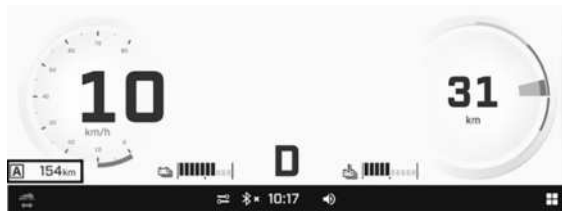

### Left Lateral Display.

- Speedometer
- Trip meter

### Center Display.

- High voltage battery capacity
- Drive selection (forward or reverse)
- High voltage battery temperature



**Right Lateral Display.** In full view mode, it includes:

- Performance gauge
- Vehicle range



- A. Vehicle range*
- B. Current performance*
- C. Discharge limit*
- D. Regenerative braking limit*

The performance gauge is located on the right side of the touchscreen display.

The range is displayed at the center of the gauge. It adjusts automatically depending on usage and operating conditions.

The thick curve, which varies instantaneously on both the discharge and regenerative braking portions, represents the actual usage of the vehicle's powertrain. The outer thin lines indicate the maximum available performance, which may be influenced by factors such as the propulsion battery state of charge, the powertrain components' temperature and the key type. Any limitation will cause them to be partially shaded.

The performance gauge also display the amount of regenerative braking that is occurring can be monitored in this area of the power meter.



The amount of regenerative braking that is occurring can be monitored in this area of the power meter.

## Narrow View Display

To change from full view to narrow view, open an applet or slide the divider on the right side.

To change back to full view, long press on applet switcher or slide the divider back in place.

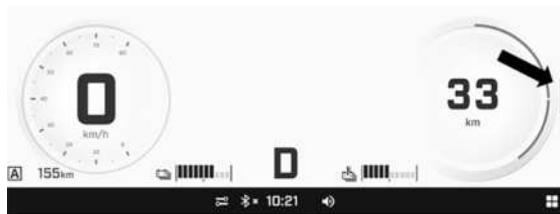

The size of the left and right lateral displays cannot be adjusted.

## Left Lateral Display

In narrow view, the left lateral display includes:

- Speedometer and performance gauge
- Trip meter
- Drive mode
- High-voltage battery state of charge
- High-voltage battery temperature

In narrow view, long press the tripmeter to show one of the following options. Cycle through the options with additional long presses.

- Current ride distance
- Trip A distance
- Trip A hours
- Trip B distance
- Trip B hours
- Current ride hours

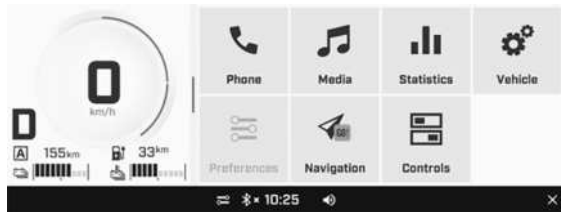

## Right Lateral Display

In narrow view, the right lateral display includes various apps. Refer to *App Menu* for more information.

## Applet Menu

To access the applet menu, press the applet menu icon on the bottom-right corner.

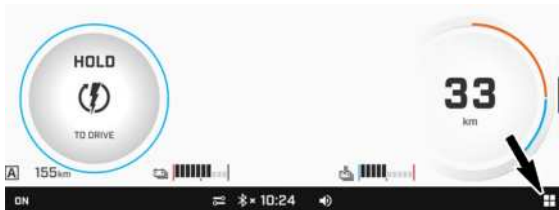

Press on an applet icon to open it.

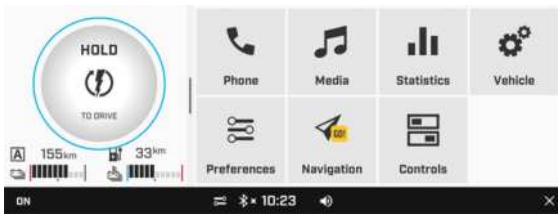

## Phone

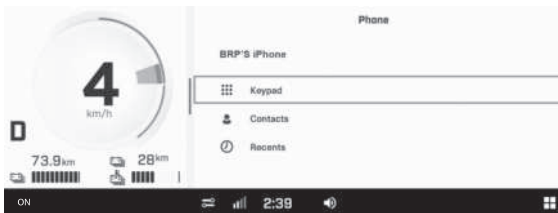

The Phone applet menu is used to access the:

- Keypad
- Phone contact list
- Phone history

NOTE:

To have access to the Phone menu, a phone and rider helmet (Headset) must be paired. Refer to *Pairing your Smartphone Via Bluetooth*.

## Media

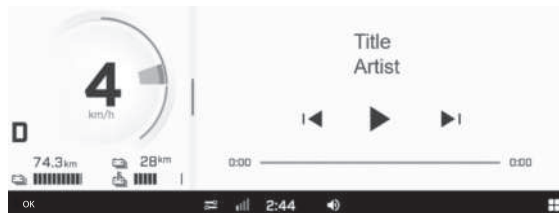

The Media applet is used to:

- Control song choice in the helmet audio system
- View song information (when available)

This vehicle is not equipped with speakers. An appropriate helmet audio system is required to listen to music.

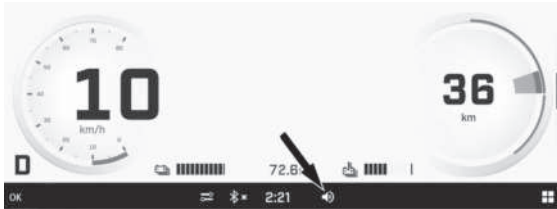

Volume can be adjusted using the status bar volume icon on the touchscreen.

## Statistics

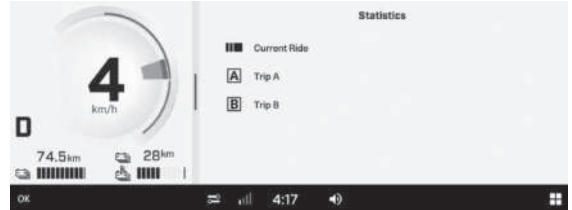

The Statistics applet is used to access :

- Trip distance information
- Trip elapsed time information
- Average speed

Three sets of statistics are stored in memory. Trip A and Trip B can be reset independently. Current ride statistics will be reset when the vehicle restart.

---

## Vehicle Settings



The Vehicle Settings applet is used to:

- View vehicle health, including:
  - Vehicle information
  - Faults (codes and description)

## Preferences

The Preferences applet is used to:

- Adjust the display brightness and appearance (Light/Dark/Auto)
- Pair Bluetooth devices:
  - Phone
  - Driver headset
  - Passenger headset
- Connect the vehicle to a Wi-Fi network
- Access general settings:
  - Adjust the units (Imperial/Metric)
  - Set the language
  - Set the date and time
  - Perform a software update

- Get information about manufacturer information and device regulatory compliance
- Reset to factory settings
- Define the applets to be used with the applet switcher button while riding

It is recommended to check for software updates regularly.

### Navigation

#### With the BRP GO! App

To use the Navigation on the display with the BRP GO! app, you must connect (USB connection) a mobile device.



#### NOTICE

For more information on the BRP GO! app, see the BRP GO! section in this manual or visit the Ski-Doo website.

## NOTICE

The smartphone must be connected with a USB cable to the USB port located in the glove box.

The user's personal data will be deleted from the cluster when the device is disconnected.

The user agrees that personal data (contact list and call history) will be transferred to the cluster when device is connected.

A compatible device with an active data plan is required to use the BRP GO! app.

### With the Built-In GPS (If Equipped)

Select Navigation in the applet menu.

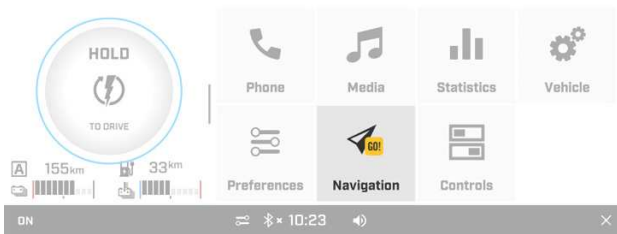



The map will be displayed and several options will become available.

- Vehicle live location
- Map Options

- Zoom In/Out
- Re-Center
- Compass

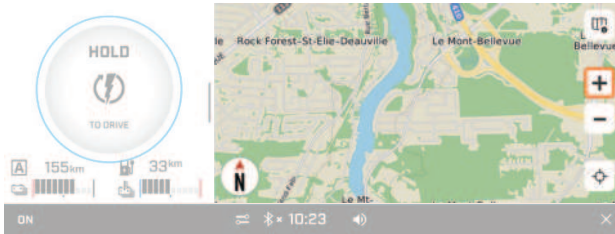

In Map Options, select Breadcrumbs to show or hide the points created from the vehicle path on the way out. This set of points will allow the operator to drive the same path on the way back.

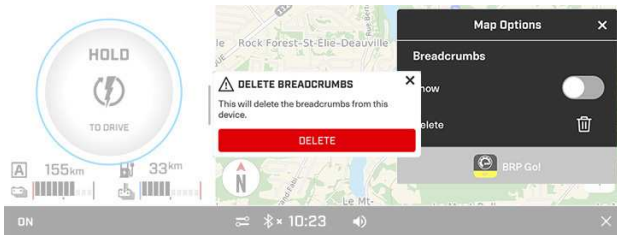

The current Breadcrumbs can be deleted to start a new path.

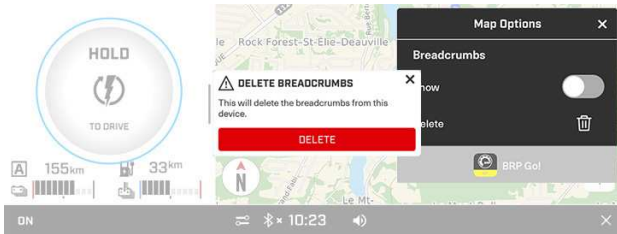

In Map Options, select BRP GO! to use the maps and the settings from the phone app. Refer to *BRP GO! App*.

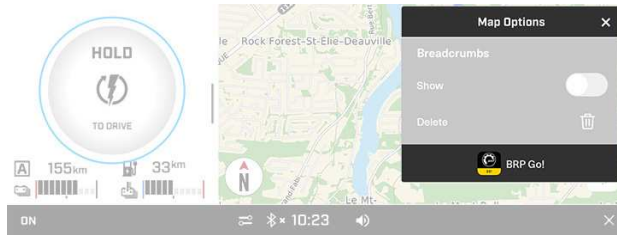

Follow the on-screen instructions.

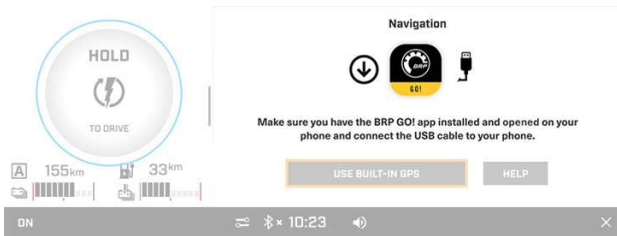

If one or several maps are downloaded directly in the 10.25" Color Touchscreen Display, they can be accessed using the "Use Built-In GPS" option without connecting a phone. Use the "Help" option for troubleshooting.

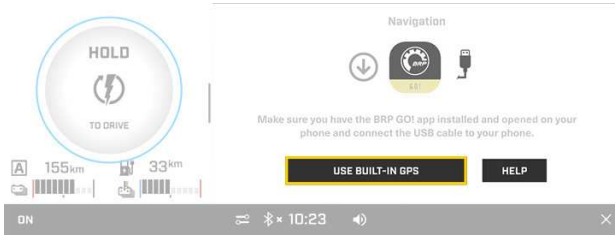

4

## Quick Preferences

To access the Quick Preferences menu, press the following icon.



The Quick Preferences menu is used to:

- Adjust the display appearance (Light/Dark/Auto)
- Lock the screen (press and hold anywhere on the screen to unlock)
- Add a Bluetooth device
- View connected Bluetooth devices.

## Warning Lamps and Indicators

The following indicator lamps will alert you to a vehicle condition that may become serious. Some lamps will illuminate when starting the vehicle to make sure they work. If any lamps remain on after starting the vehicle, refer to the respective system warning lamp for further information.



Some warning indicators appear in the display of the multifunction gauge and function the same as an indicator lamp but do not display when starting the vehicle.

## Telltails



The telltales lights are found in two locations of the instrument cluster:

- Digital bar
- Physical bar

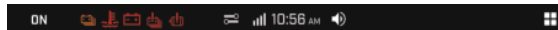



## Digital Bar







### DIGITAL PILOT LAMP - 10.25" COLOR DIGITAL TOUCHSCREEN

<i>Lights</i>	<i>Description</i>
	RED - Coolant temperature
	AMBER - Automatic power reduction (due to system malfunction)
	RED - Propulsion battery failure

## VEHICLE INFORMATION



<i>Lights</i>	<i>Description</i>
	AMBER - Propulsion battery state of charge is low
	AMBER - Electrical fault or problem detected with the charging system
	RED - 12V battery voltage too low or there is a problem with the electrical system
	External cord connected

<i>Lights</i>	<i>Description</i>
	AMBER - Error with the connected external cord
	RED - Electric motor failure
	Charging indicator
	Vehicle ON indicator
	Vehicle READY indicator





## Physical Bar



Pilot Lamps – 10.25” Color Digital Touchscreen

<i>Lights</i>	<i>Description</i>
	AMBER - Vehicle malfunction
	BLUE - The high beams are selected
	RED - Parking brake is engaged or malfunction of the brake system

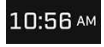
## Icons and Indicators - Status Bar

<i>Icon</i>	<i>Description</i>
	Shut down
	Quick Preferences
	Smartphone network connection
	Clock
	Audio volume
	Applet menu



### Pairing your Smartphone via Bluetooth

#### On the Vehicle

1. Open the Applet menu
2. Select “Preferences”
3. Select “Bluetooth”

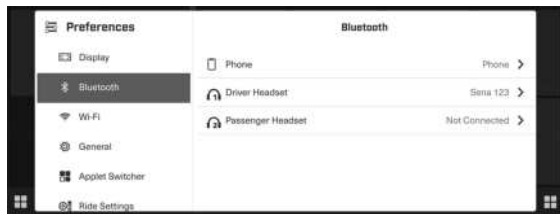

4. Select “Phone”

5. Select “Add Device”

#### NOTICE

More than one smartphone can be paired with the vehicle. However, only one will connect at any given time.

#### On the Phone

1. Activate your phone's Bluetooth function.

Refer to your manufacturer's user guide for detailed procedure.

2. Select the name of your phone in the list of available devices.
3. A confirmation number will appear on the display and on the phone. Make sure that the numbers match.
4. Select Pair.
5. Allow Contacts and Favorite Sync.

---

## Pairing a Headset

To pair a headset, refer to *Pairing your Smartphone Via Bluetooth* and select “Driver Headset” or “Passenger Headset”.

## Messages in Multifunction Display

Important information about your vehicle condition is displayed on the multifunction display. When starting the vehicle, always look at the display for any tell-tales and indicators or messages.

Important information messages can also be displayed temporarily to assist tell-tales and indicators.

Notifications will always appear at the top right corner of the screen.

There are two types of notifications:

- Vehicle notifications include warning, caution and notice messages
- Infotainment notifications include messages regarding connected devices

Vehicle notifications have priority over infotainment notifications when they are both present at the same time.

In the event that the vehicle goes into limited power mode, BRP recommends having the vehicle transported. If you operate the vehicle in limited power mode, avoid abrupt maneuvers and immediately go to the nearest authorized BRP snowmobile dealer to have your vehicle serviced before riding again. In limited power mode, power and vehicle speed are limited.

### **BRP GO! App**

#### **1) Download the BRP GO! Smartphone App**

Download the BRP GO! app via the App Store for Apple™ or the Google™ Play Store for Android.

#### **2) Connect your smartphone using a USB cable**

It is recommended to use an original USB charging cable from the smartphone OEM to optimize transfer between the phone and the vehicle. Use the front USB port.

Make sure you accept the permissions requested by BRP GO! on your phone. If certain permissions are not accepted, connection issues could result.

1. Unlock your phone
2. Connect your phone charging cable

3. A checkmark will appear on your phone screen when the connection is successful

#### **3) Access your apps**

Press the App Menu icon to access apps.

Select “Navigation.”

---

## Quick Tour of the BRP GO! App



1. **Playground:** Select your playground to see content related to your vehicle. For Ski-Doo snowmobiles, select the Snow playground.
2. **Navigation:** Access all the navigation features of the app, such as route planning, turn-by-turn navigation, friends' locations, offline navigation and more. You can access thousands of snowmobile trails across North America and Europe on the map.
3. **Connect to my vehicle:** Easily access content on how to connect the BRP GO! app to your vehicle's display.
4. **Devices:** Add and manage your Vibe communication system.
5. **FAQ:** This link takes you to answers of common questions asked by riders like you. An internet connection is required.
6. **Rides:** Easily access your planned and completed rides made with the app.

7. My Profile: Manage your profile and your account settings.

---

## RIDING CONDITIONS AND YOUR SNOWMOBILE

### Hard Packed Snow

All models covered in this guide which are equipped with a minimum track profile of 44 mm (1.75 in) are built for deep snow conditions and should never be used during a prolonged period of time in marginal or hard packed snow conditions.

In the event you have to ride in these types of conditions:

- Avoid exceeding a speed of 70 km/h (45 mph) in all conditions
- Avoid hard acceleration (over 75% of accelerator)
- Ice scratchers should be applied

#### NOTICE

Running these types of tracks at high speed on a trail, on hard packed surfaces or on ice puts more stress on the lugs, which tend to heat up as a result. It also could drastically reduce the life of specific wear parts. To avoid potential degradation, delamination or damages to the track and wear parts, reduce your speed and minimize the distance that is being ridden on these types of surfaces.

### Vehicles Equipped with Ice Scratchers

Ice scratchers are equipped on the vehicle to lubricate and cool track clips and sliders. They must be used whenever on ice, hard packed snow or any conditions that do not lift enough snow particles into the rear suspension and the tunnel. Also, it is beneficial to use ice scratchers whenever possible in order to maximize EV range.

### *NOTICE*

Riding in these trail conditions puts the reliability of the track and its warranty at risk.

---

## TUNE YOUR RIDE

Snowmobile handling and comfort depend upon multiple adjustments.

 **WARNING**

Suspension adjustment could affect vehicle handling. Always take time to familiarize yourself with the vehicle's behavior after any suspension adjustments have been made. Always adjust LH and RH suspension components to the same setting.

Choice of suspension adjustments vary with carrying load, operator's weight, personal preference, riding speed and field conditions.

**NOTICE**

Some adjustments may not apply to your snowmobile.



 **WARNING**

Before proceeding with any suspension adjustment, remember:

- Park in a safe place.
- Remove the tether cord cap from the cut-off switch.
- Use appropriate lifting device or have assistance to share lifting stress. If a lifting device is not used, use proper lifting techniques, including lifting with your legs.
- Do not attempt to lift the front or rear of vehicle if it is above your limits.
- Support front of vehicle off the ground with a suitable device before adjusting suspension.
- Support rear of vehicle off the ground with a wide-base snowmobile stand with a rear deflector panel.
- Make sure support device is stable and secure.

The best way to set up the suspension is to customize each adjustment one at a time. Various adjustments are interrelated. It may be necessary to readjust center spring after adjusting front springs for instance. Test run the snowmobile under the same conditions (trail, speed, snow, operator riding position, etc). Proceed methodically until you are satisfied.

Following are guidelines to fine-tune suspension. Use the suspension adjustment tool provided in the tool kit.

## Front Suspension Adjustments

Vehicle Deactivation Level:	
-----------------------------	---

See *Vehicle Deactivation Classification* for more information.

### Front Springs

Front spring preload has an effect on front suspension firmness.

Front spring preload also has an effect on the steering behavior.

<b>Action</b>	<b>Result</b>
Increasing preload	Firmer front suspension

<b>Action</b>	<b>Result</b>
	Higher front end
	More precise steering
	More bump absorption capability
	Increased drag / reduced range
Decreasing preload	Softer front suspension
	Lower front end
	Lighter steering
	Less bump absorption capability

<i>Action</i>	<i>Result</i>
	Reduced drag / increased range

 **WARNING**

Adjust both springs to the same preload. Uneven adjustment can cause poor handling and loss of stability and/or control and increase the risk of an accident.

### Cam Type Adjuster

Using the suspension adjustment tool provided in the tool kit, turn the cam to increase or decrease the spring preload.

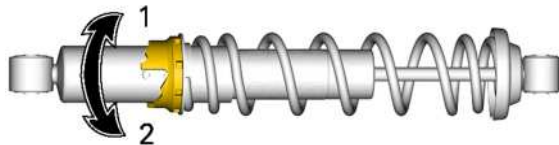

1. Increase preload
2. Decrease preload

4

## Rear Suspension Adjustments

Vehicle Deactivation Level:	
-----------------------------	---

See *Vehicle Deactivation Classification* for more information.

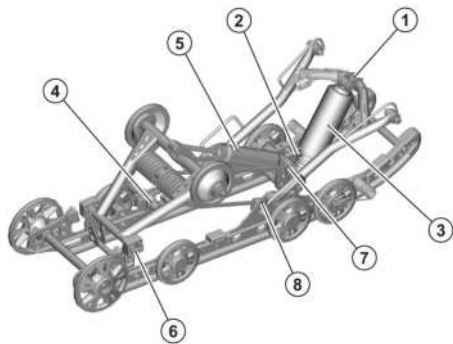

### SC-5 120

1. Stopper strap
2. Center spring
3. Center shock absorber
4. Rear spring
5. Rear shock absorber
6. Coupling blocks
7. Rear shock lower pivot
8. Front arm

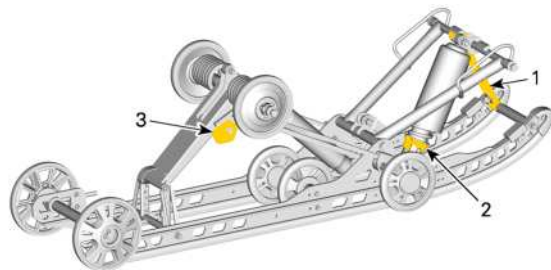

### SC-5M 137

1. Stopper strap
2. Center spring
3. Rear spring

#### NOTICE

Whenever adjusting rear suspension, check track tension and adjust if necessary.

## Adjustment Tips According to Vehicle Behavior

<i>Problem</i>	<i>Corrective Measures</i>
Front suspension darting	<p>Check ski alignment.</p> <ul style="list-style-type: none"> <li>• Reduce front suspension spring preload</li> <li>• Increase center spring preload</li> <li>• Reduce rear spring preload</li> </ul>
Steering feels too heavy at steady speeds	<ul style="list-style-type: none"> <li>• Reduce front suspension spring preload</li> <li>• Increase center spring preload</li> </ul>

<i>Problem</i>	<i>Corrective Measures</i>
Steering feels too heavy during acceleration	<ul style="list-style-type: none"> <li>• Set coupling blocks to a lower position (if equipped)</li> <li>• Reduce rear spring preload</li> <li>• Lengthen limiter strap</li> </ul>
Too much ski lift during cornering or acceleration	<ul style="list-style-type: none"> <li>• Set coupling blocks to a higher position (if equipped)</li> <li>• Shorten limiter strap</li> <li>• Increase rear spring preload</li> </ul>

<b><i>Problem</i></b>	<b><i>Corrective Measures</i></b>
Rear of snowmobile seems too stiff	<ul style="list-style-type: none"> <li>• Reduce rear spring preload</li> <li>• Reduce compression damping adjustment (if equipped)</li> </ul>
Rear of snowmobile seems too soft	<ul style="list-style-type: none"> <li>• Increase rear spring preload</li> </ul>
Rear suspension is frequently bottoming	<ul style="list-style-type: none"> <li>• Increase compression damping adjustment (if equipped)</li> <li>• Increase rear spring preload</li> <li>• Increase center spring preload</li> </ul>

<b><i>Problem</i></b>	<b><i>Corrective Measures</i></b>
	<ul style="list-style-type: none"> <li>• Lengthen limiter strap</li> </ul>
Snowmobile seems to pivot around its center	<ul style="list-style-type: none"> <li>• Reduce center spring preload</li> <li>• Increase rear spring preload</li> <li>• Increase front suspension spring preload</li> <li>• Shorten limiter strap</li> </ul>
Track spins too much at start	<ul style="list-style-type: none"> <li>• Set coupling blocks to a lower position (if equipped)</li> <li>• Lengthen limiter strap</li> </ul>

## **5** MAINTENANCE - TABLE OF CONTENTS

---

<b>MAINTENANCE SCHEDULE</b> .....	<b>5-2</b>	<b>STORAGE</b> .....	<b>5-43</b>
Trail / Crossover / Utility Usage. ....	5-2	<b>PRESEASON PREPARATION</b> .....	<b>5-46</b>
Maintenance Schedule .....	5-3	<b>MAINTENANCE RECORDS</b> .....	<b>5-47</b>
<b>MAINTENANCE PROCEDURES</b> .....	<b>5-10</b>		
Coolant .....	5-10		
Brake Fluid .....	5-12		
Chaincase Oil .....	5-17		
Drive Chain .....	5-21		
Track .....	5-22		
Suspension .....	5-31		
Skis .....	5-34		
Fuses .....	5-34		
Headlights .....	5-36		
12V Battery .....	5-37		
<b>VEHICLE CARE</b> .....	<b>5-41</b>		
Post-Operation Care .....	5-41		
Vehicle Cleaning and Protection .....	5-41		

---

## MAINTENANCE SCHEDULE

Maintenance is very important to keep your vehicle in a safe operating condition. The vehicle should be serviced as per the maintenance schedule.

Proper maintenance is the owner's responsibility. A warranty claim may be denied if, among other things, the owner or operator caused the problem through improper maintenance or use.

Perform periodic checks and follow the maintenance schedule. **The maintenance schedule does not exempt the pre-ride inspection.**



Failure to properly maintain the vehicle according to the maintenance schedule and procedures can make it unsafe to operate.

### Trail / Crossover / Utility Usage

Whether your vehicle is a Trail, Crossover, or Utility model, it requires yearly maintenance. These items are identified as A in the chart below.

If you regularly ride in **trails, explore the countryside or work** with your snowmobile, follow the A+ Trail / Crossover / Utility interval and perform the tasks outlined in the chart below.



## Maintenance Schedule

Make sure to perform proper maintenance at recommended intervals as indicated in the tables.

The maintenance chart indicates items needing to be addressed based on 2 criteria, whichever happens first:

- Calendar time
- Odometer reading

Your driving habits determine the factors you should adhere to. For example:

- Someone who uses their vehicle every other weekend trail riding with friends would most likely follow the **odometer reading** to determine the frequency of his maintenance.
- Someone who uses their vehicle seldomly over the year or only on a few occasions would follow the **calendar time** to determine the frequency of his maintenance.

### NOTICE

The following tables show the appropriate maintenance application for the first 3 years. For subsequent years, repeat the same pattern alternatively.

---

## Maintenance Overview

Calendar Time	Odometer	Trail / Cross Over / Utility
Every Month	1500 km (1000 mi)	<b>A+</b>
1 Year	3000 km (2000 mi)	<b>A</b>
Every Month	4500 km (3000 mi)	<b>A+</b>
2 Years	6000 km (4000 mi)	<b>A and B</b>
Every Month	7500 km (5000 mi)	<b>A+</b>

## Rotax E-Power

<b>TRAIL / CROSSOVER / UTILITY</b>	<b>A+</b>	<b>A</b>	<b>B</b>
<i>A = Adjust</i> <i>C = Clean</i> <i>I = Inspect</i> <i>L = Lubricate</i> <i>R = Replace</i> <i>T = Torque</i>	<i>Every month or 1500 km (1000 mi)</i>	<i>Every year or 3000 km (2000 mi)</i>	<i>Every 2 years or 6000 km (4000 mi)</i>
<b>Body and Chassis</b>			
Body panels and hardware		I, T	
Pivots, latches, hinges and key barrels		L	
<b>Cooling</b>			
Coolant	I	R Every 5 years	

<b>TRAIL / CROSSOVER / UTILITY</b>	<b>A+</b>	<b>A</b>	<b>B</b>
<b>A = Adjust</b> <b>C = Clean</b> <b>I = Inspect</b> <b>L = Lubricate</b> <b>R = Replace</b> <b>T = Torque</b>	<b>Every month</b> <b>or</b> <b>1500 km</b> <b>(1000 mi)</b>	<b>Every year</b> <b>or</b> <b>3000 km</b> <b>(2000 mi)</b>	<b>Every 2 years</b> <b>or</b> <b>6000 km</b> <b>(4000 mi)</b>
Cooling components (coolant concentration, coolant level, hose condition, clamps, leaks)	I	I	
<b>Brake</b>			
Brake components and function		I, L	
Brake fluid		R Every 2 years	
<b>Drive</b>			
Gearbox / chaincase oil level	I	I	

<b>TRAIL / CROSSOVER / UTILITY</b>	<b>A+</b>	<b>A</b>	<b>B</b>
<b>A = Adjust</b> <b>C = Clean</b> <b>I = Inspect</b> <b>L = Lubricate</b> <b>R = Replace</b> <b>T = Torque</b>	<b>Every month</b> or <b>1500 km</b> (1000 mi)	<b>Every year</b> or <b>3000 km</b> (2000 mi)	<b>Every 2 years</b> or <b>6000 km</b> (4000 mi)
Track alignment and tension	<b>A</b>	<b>I, A</b>	
Gearbox / chaincase oil			<b>R</b>
<b>Low-Voltage Electrical</b>			
12V battery connections and condition		<b>I</b>	
Low voltage electrical harness routing		<b>I</b>	
Headlight aim		<b>A</b>	
Operation of control switches and lighting		<b>I</b>	

<b>TRAIL / CROSSOVER / UTILITY</b>	<b>A+</b>	<b>A</b>	<b>B</b>
<b>A = Adjust</b> <b>C = Clean</b> <b>I = Inspect</b> <b>L = Lubricate</b> <b>R = Replace</b> <b>T = Torque</b>	<b>Every month</b> <b>or</b> <b>1500 km</b> <b>(1000 mi)</b>	<b>Every year</b> <b>or</b> <b>3000 km</b> <b>(2000 mi)</b>	<b>Every 2 years</b> <b>or</b> <b>6000 km</b> <b>(4000 mi)</b>
Modules and applicable software updates		I	
<b>High-Voltage Electrical</b>			
Charging Port		I	
High voltage cables		I	
High voltage components cooling		I	
<b>Steering and Controls</b>			
Accelerator operation	I	I	

<b>TRAIL / CROSSOVER / UTILITY</b>	<b>A+</b>	<b>A</b>	<b>B</b>
<b>A = Adjust</b> <b>C = Clean</b> <b>I = Inspect</b> <b>L = Lubricate</b> <b>R = Replace</b> <b>T = Torque</b>	<b>Every month</b> or <b>1500 km</b> (1000 mi)	<b>Every year</b> or <b>3000 km</b> (2000 mi)	<b>Every 2 years</b> or <b>6000 km</b> (4000 mi)
Ski runners	I	I	
Steering alignment		I, A	
Steering components and function		I	
<b>Suspension</b>			
Suspension components and function		I, L	

## MAINTENANCE PROCEDURES

This section includes instructions for basic maintenance procedures.

### WARNING

Turn off the vehicle, remove tether cord cap and follow these maintenance procedures when performing maintenance. If you do not follow proper maintenance procedures you can be injured by hot parts, moving parts, electricity, chemicals or other hazards.

### WARNING

Should removal of a locking device be required (e.g. lock tabs, self-locking fasteners, etc.) when undergoing disassembly/assembly, always replace with a new one.

## Coolant

Vehicle Deactivation  
Level:



See *Vehicle Deactivation Classification* for more information.

### WARNING

Never open cooling system reservoir cap when coolant is hot.

## Coolant Level Verification

Open the RH side panel. See *Body and Seat*.

Check coolant level at room temperature. Liquid should be at cold level line of coolant tank.



**NOTE:**

When checking level at low temperature, it may be slightly lower than the mark.

If additional coolant is necessary or if entire system has to be refilled, refer to an authorized BRP snowmobile dealer, repair shop or person of your own choosing.

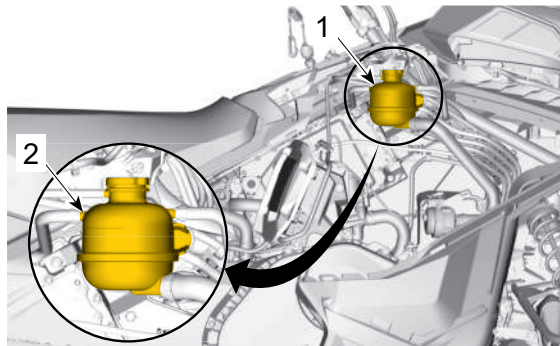

1. Coolant reservoir
2. COLD line

## Recommended Coolant

<b><i>RECOMMENDED COOLANT</i></b>
XPS Extended life pre-mixed coolant
<b>IF THE RECOMMENDED XPS COOLANT IS NOT AVAILABLE</b>
OAT type antifreeze

### ***NOTICE***

Always use low conductivity coolant specifically formulated for electric vehicles.

## Brake Fluid

Vehicle Deactivation Level:	
-----------------------------	---

See *Vehicle Deactivation Classification* for more information.

## Verifying the Brake Fluid Level

### ***NOTICE***

Vehicle must be on a level surface before checking any fluid levels.

1. Position the handlebar in the straight-ahead position to ensure the reservoir is level.

2. Check brake fluid in the reservoir for proper level.

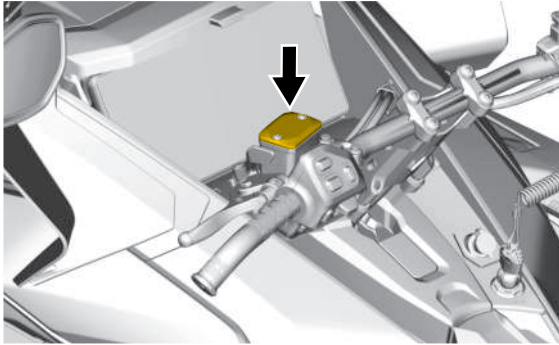

Typical

Brake fluid must always be above the bottom of the window when brake lever is squeezed.

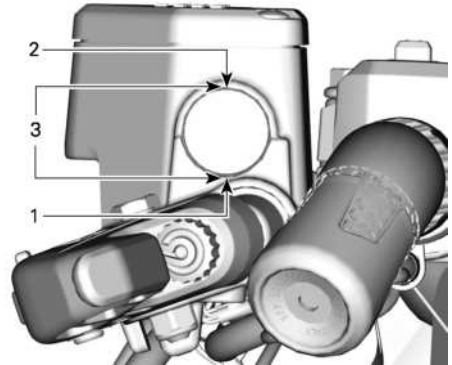

5

Typical

1. Minimum
2. Maximum
3. Operating range

## Adding Brake Fluid

### NOTICE

Vehicle must be on a level surface before checking any fluid levels.

1. Clean the reservoir cap.

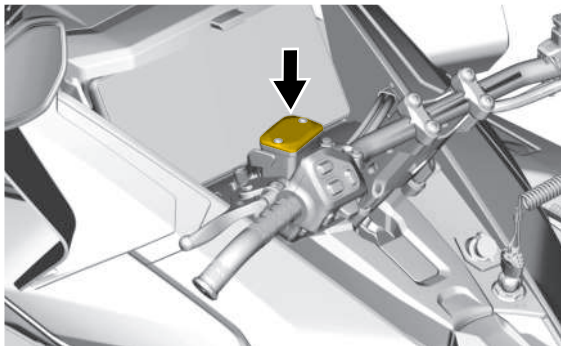

2. Remove the screws retaining the reservoir cap.

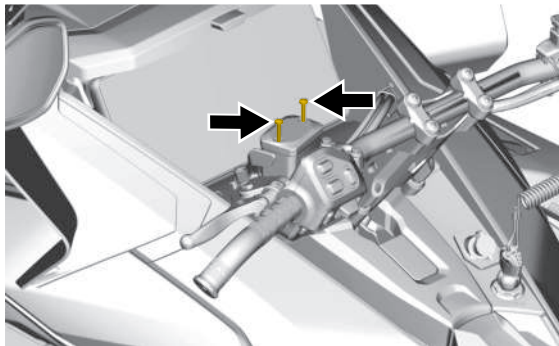

3. Remove the reservoir cap.

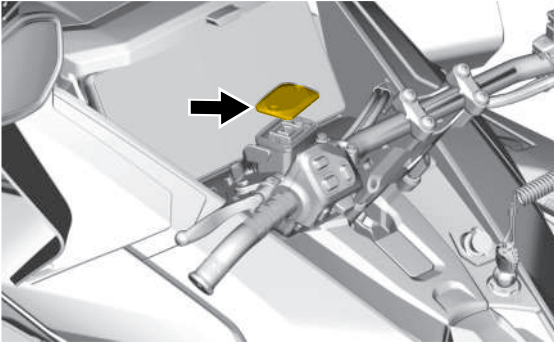

4. Add fluid as required. Do not overfill. Use only the recommended brake fluid. Refer to *Recommended Brake Fluid* in this subsection.

### ⚠ CAUTION

Avoid getting brake fluid on skin or eyes - it may cause severe burns. In case of contact with the skin, wash thoroughly. In case of contact with the eyes, immediately rinse with plenty of water for at least 10 minutes and then consult a doctor immediately.

### NOTICE

- Brake fluid can damage paint, rubber and plastic parts
- Protect these nearby parts with a rag when servicing the brake system
- Rinse thoroughly in case of spillage

5. Ensure the diaphragm is pushed in the reservoir cap before installing the cap on the reservoir.

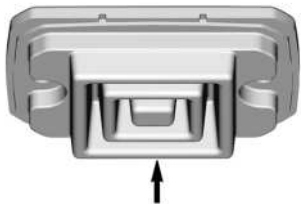

6. Reinstall reservoir cap and screws. Tighten to specification.

Tightening Torque	
Reservoir cap screws	$0.7 \pm 0.1$ Nm ( $6 \pm 1$ lbf-in)

## Recommended Brake Fluid

<b><i>Recommended Brake Fluid</i></b>
XPS DOT 4 Brake Fluid
<b>Alternative or if not available</b>
DOT 4 Brake Fluid

Use only DOT 4 brake fluid from a sealed container. An opened container may be contaminated or may have absorbed moisture from the air.

### WARNING

Use only DOT 4 brake fluid from a sealed container. To avoid serious damage to the braking system, do not use fluids other than the recommended one, nor mix different fluids for topping up.

## Chaincase Oil

Vehicle Deactivation Level:	
-----------------------------	---

See *Vehicle Deactivation Classification* for more information.

## Recommended Chaincase Oil

<b><i>Recommended Chaincase Oil</i></b>
XPS Synthetic gearcase oil
<b>Alternative or if not available</b>
75W140 gear oil that meets the API GL-5 specification

### NOTICE

If the recommended XPS gearcase oil is not available, use a 75W140 gear oil that meets the API GL-5 specification. The gearcase of this snowmobile has been developed and validated using the XPS™ Synthetic gearcase oil. BRP strongly recommends the use of its XPS Synthetic chaincase oil at all times. Damages caused by oil which is not suitable for the chaincase will not be covered by the BRP limited warranty.

## Verifying the Chaincase Oil Level

With the vehicle on a level surface, check the oil level by removing the check plug.

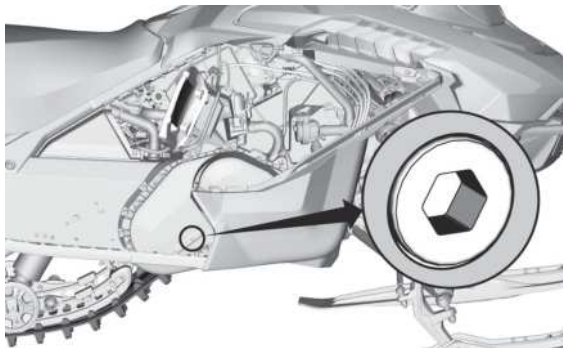

**Check plug**

The oil level must reach the threaded hole.

If the level is correct, reinstall the check plug to the specified torque.

<b><i>Tightening Torque</i></b>	
Check plug	$6 \pm 1$ Nm ( $53 \pm 9$ lbf-in)

If level is insufficient, refer to *Chaincase Filling Procedure*.



## Replacing the Chaincase Oil

### Draining the Chaincase Oil

Vehicle Deactivation  
Level:



Refer to *Vehicle Deactivation Classification* for more information.

1. Place the vehicle on a level surface.
2. Apply the parking brake.
3. Lift the front of the vehicle.
4. Place a drain pan under the chaincase drain plug area.
5. Remove the filler cap.

6. Remove the drain plug located at the bottom of the chaincase.

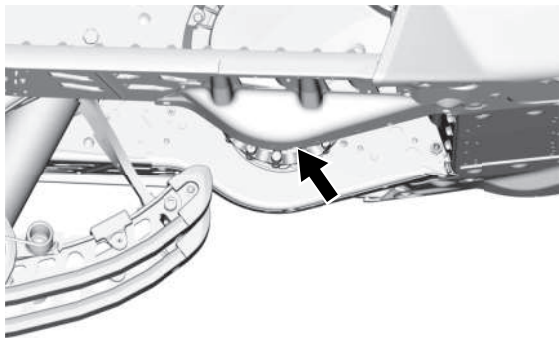

7. Wait a while to allow all oil to drain out of the chaincase.
8. Lower the front of the vehicle.

9. Install drain plug and tighten to specification.

<b><i>Tightening Torque</i></b>	
Chaincase drain plug	$6 \pm 1$ Nm ( $53 \pm 9$ lbf-in)

### **Filling the Chaincase**

Vehicle Deactivation Level:	
-----------------------------	---

Refer to *Vehicle Deactivation Classification* for more information.

1. Open the RH side panel. Refer to *Equipment*.

2. Remove the check plug.

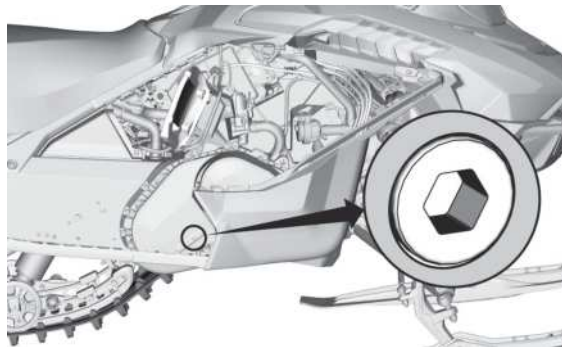

**Check plug**

3. Remove the filler cap.

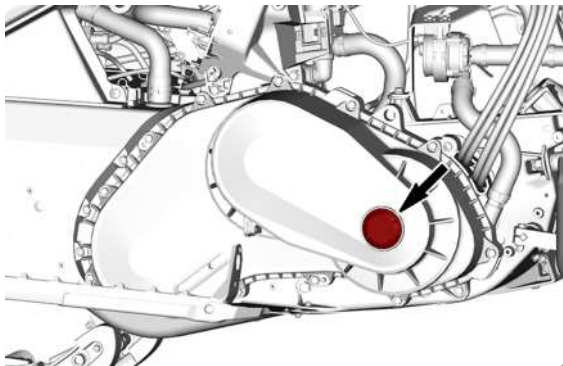

4. Pour recommended oil in the filler hole until oil comes out by the check plug hole.
5. Reinstall the check plug and tighten to specification.

## Tightening Torque

Check plug	$6 \pm 1 \text{ Nm}$ ( $53 \pm 9 \text{ lbf-in}$ )
------------	--

Reinstall the filler cap.

## Drive Chain

Vehicle Deactivation Level:	
-----------------------------	--

See *Vehicle Deactivation Classification* for more information.

## Access to Chaincase

Open RH side panel, refer to *Equipment*.

---

## Track

Vehicle Deactivation Level:	
-----------------------------	---



Refer to *Vehicle Deactivation Classification* for more information.

## Track Condition



Remove the tether cord cap from the vehicle cut-off switch before performing any maintenance or adjustment, unless otherwise specified. The vehicle must be parked in a safe place, away from the trail.

Remove the tether cord cap from the vehicle cut-off switch.

Lift the rear of the snowmobile and support it using a wide-base snowmobile mechanical stand with a rear deflector panel. With the vehicle off, rotate the track by hand, and inspect condition. If worn or cut, if track fibers are exposed or if missing or defective inserts or guides are noted, contact an authorized BRP snowmobile dealer.

## Snowmobiles Equipped with Traction Enhancing Products

If your snowmobile is equipped with a BRP approved studded track, **PROCEED WITH A VISUAL INSPECTION OF YOUR TRACK BEFORE EACH USE.**

Look for any defects, such as:

- Perforations in the track
- Tears in the track (particularly around traction holes on studded tracks)
- Lugs that are broken or torn off, exposing portions of rods
- Delamination of the rubber
- Broken rods
- Broken studs (studded tracks)
- Bent studs (studded tracks)
- Missing studs
- Studs that are torn off the track
- Missing track guide(s)
- Ensure that stud nuts are tightened to the recommended torque

On approved studded tracks, replace broken or damaged studs immediately. If your track shows signs of deterioration, it must be replaced immediately. When in doubt, ask your dealer.



## WARNING

Riding with a damaged track or studs could lead to a loss of control.

## Track Tension and Alignment

### NOTICE

Track tension and alignment are interrelated. Do not adjust one without the other.

**WARNING**

To prevent serious injury to individuals near the snowmobile:

- NEVER stand behind or near a moving track.
- Always use a wide-base snowmobile stand with a rear deflector panel if it is necessary to rotate the track.
- When the track is raised off the ground, only run it at the lowest possible speed.

Centrifugal force could cause debris, damaged or loose studs, pieces of torn track, or an entire severed track to be violently thrown backward out of the tunnel with tremendous force, possibly resulting in the loss of a leg or other serious injury.

## Verifying the Track Tension

**NOTICE**

Ride the snowmobile in snow about 15 to 20 minutes prior to adjusting track tension.

1. Remove the tether cord cap from the vehicle cut-off switch.
2. Lift the rear of vehicle and support it off the ground.

**CAUTION**

Use proper lifting techniques, including lifting with your legs. Do not attempt to lift the rear of vehicle if it is above your limits.

3. Allow the rear suspension to fully extend.
4. Prepare the tensiometer.

**Service tool**

Tensiometer (P/N 414348200)

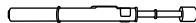

1. Set the bottom O-ring as per the *Track Deflection* from the applicable vehicle in the *Technical Specifications* table.

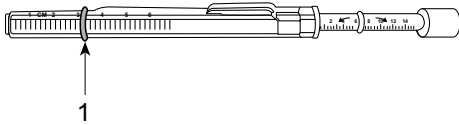

1. Bottom O-ring

2. Place the upper O-ring to 0 kgf (0 lbf).

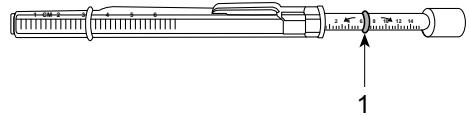

1. Upper O-ring

5. Position the tensiometer on the track, halfway between front and rear idler wheels.

6. Push the tensiometer downward until the bottom O-ring (deflection set earlier) is aligned with the bottom of slider shoe.

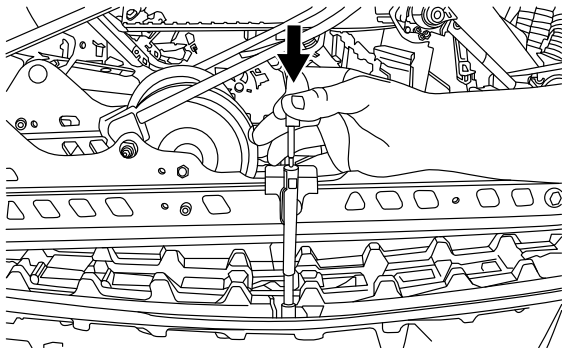

**Typical**

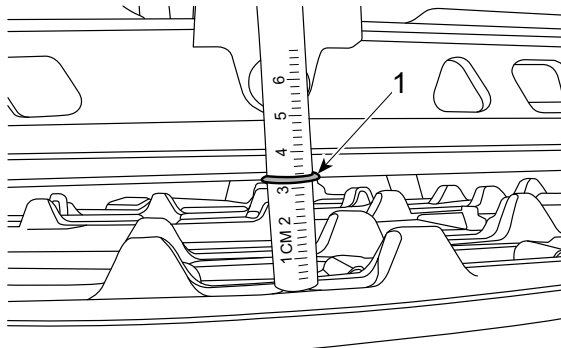

**1. Deflection O-ring aligned with slider shoe**



7. Read the load recorded by the upper O-ring on the tensiometer.

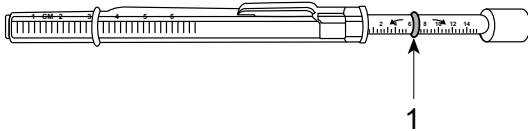

## Typical - Load Reading

1. Upper O-ring

8. The load reading must be as per the track deflection in the *Technical Specifications*.

9. If the load reading is not in accordance with the specification, adjust the track tension. Refer to *Track Tension Adjustment*.

## Adjusting the Track Tension

1. Remove the tether cord cap from the vehicle cut-off switch.



Use proper lifting techniques, including lifting with your legs. Do not attempt to lift the rear of vehicle if it is above your limits.

2. Remove the wheel caps.
3. Loosen the rear axle screw or, on 2 idler wheel models, the rear axle nut.

4. Tighten or loosen both adjustment screws (equally) to increase or decrease track tension.

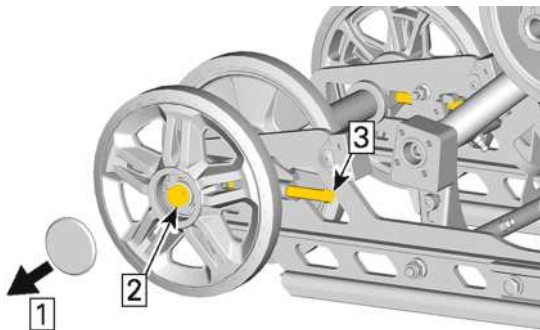

### Typical - SC-5 120 Suspension Shown

1. Remove cap
2. Loosen the axle screw or nut
3. Tighten or loosen adjustment screws

5. If correct tension is unattainable, contact an authorized BRP snowmobile dealer.
6. Retighten the rear axle fasteners to specification.

<b>TIGHTENING TORQUE</b>	
Rear idler wheel retaining screws	$48 \pm 6$ Nm ( $35 \pm 4$ lbf-ft)

7. Check track alignment as described below.

## Aligning the Track

### WARNING

Before checking track alignment, ensure that the track is free of all particles which could be thrown out while track is rotating. Keep hands, tools, feet and clothing clear of track. Always lift the snowmobile on a wide-base stand with a rear deflector panel. Ensure no one is standing in close proximity to the snowmobile, especially at the rear of the track. Never rotate track at high speed.

Centrifugal force could cause debris, damaged or loose studs, pieces of torn track, or an entire severed track to be violently thrown backwards out of the tunnel with tremendous force.

1. Lift the rear of the vehicle and support it off the ground.

### CAUTION

Use proper lifting techniques, including lifting with your legs. Do not attempt to lift the rear of vehicle if it is above your limits.

2. Start the vehicle and accelerate slightly so that the track slowly turns. This must be done in a short period of time (15 to 20 seconds).
3. Check that the track is well centered; equal distance on both sides between edges of track guides and slider shoes.

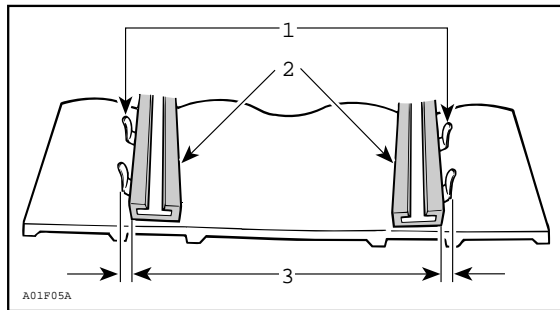

1. Guides
2. Slider shoes
3. Equal distance

4. To correct track alignment:

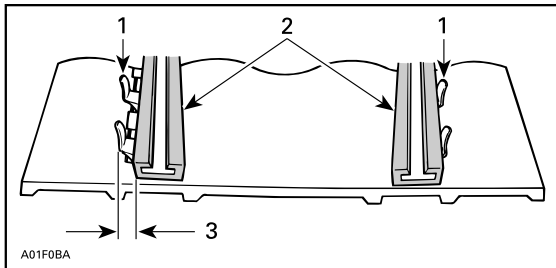

- 1. Guides
- 2. Slider shoes
- 3. Tighten on this side

1. Stop the vehicle.
2. Remove the tether cord cap from the vehicle cut-off switch.

 **WARNING**

Remove the tether cord cap from the vehicle cut-off switch before performing any maintenance or adjustment, unless otherwise specified. The vehicle must be parked in a safe place, away from the trail.

3. Loosen the rear axle nut.
4. Tighten the adjustment screw on the side where the slider shoe is the farthest from the track insert guides.

5. Tighten the rear axle nut.

 **WARNING**

Properly tighten the wheel retaining bolt, otherwise wheel may come off and cause track to "lock."

6. Restart the vehicle and rotate the track slowly to recheck the alignment.

7. Tighten the rear axle nut to the specified torque.

<b>Tightening Torque</b>	
Rear axle screw	48 ± 6 Nm (35 ± 4 lbf-ft)

8. Reposition the snowmobile on the ground.

## Suspension

<p>Vehicle Deactivation Classification:</p> 	<p><b>Mandatory Personal Protective Equipment (PPE):</b></p> <ul style="list-style-type: none"> <li>• Safety Glasses</li> <li>• Safety shoes with electric shock resistant soles</li> </ul>
--	---

See *Vehicle Deactivation Classification* for more information.

## Rear Suspension Condition

Visually inspect all suspension components including slider shoes, springs, wheels, etc.



During normal driving, snow will act as a lubricant and coolant for the slider shoes. Extensive riding on ice or sanded snow, will create excessive heat build-up and cause premature slider shoe wear.

### Suspension Stopper Strap Condition

Inspect stopper straps for wear and cracks. Inspect bolts and nuts for tightness. If loose, inspect holes for deformation. Replace as required. Tighten nut to specification.

#### ***Tightening Torque***

Stopper strap nut	7 ± 1 Nm (62 ± 9 lbf-in)
----------------------	--------------------------

### Suspension Lubrication

Lubricate the following suspension pivots at grease fittings. Refer to *Maintenance Schedule* for maintenance frequency.

#### ***SERVICE PRODUCT***

XPS Synthetic grease suspension

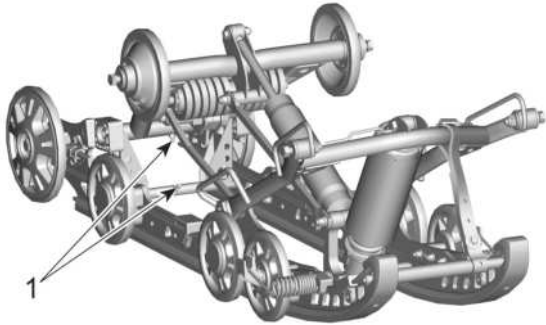

## SC-5 120

1. Grease fittings

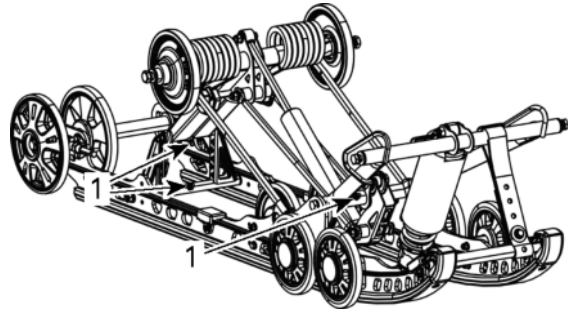

## SC-5M 137

1. Grease fittings

### Steering and Front Suspension Condition

Visually inspect the steering and the front suspension for tightness of components (steering arms, control arms and links, tie rods, ball joints, ski bolts, ski legs, etc.). If necessary, contact an authorized BRP snowmobile dealer.

## Skis

### Wear and Condition of Skis and Runners

Check the condition of the skis and ski runner carbides. If worn, contact an authorized BRP snowmobile dealer.



Excessively worn skis and/or ski runners will adversely affect snowmobile control.

## Fuses

Vehicle Deactivation  
Level:



See *Vehicle Deactivation Classification* for more information.

## Access to Fuse Block

Open LH side panel, refer to *Body and Seat*.

## Main Fuse (FA) Location

The main fuse (FA) is located under driver's seat, adjacent to the low-voltage battery.

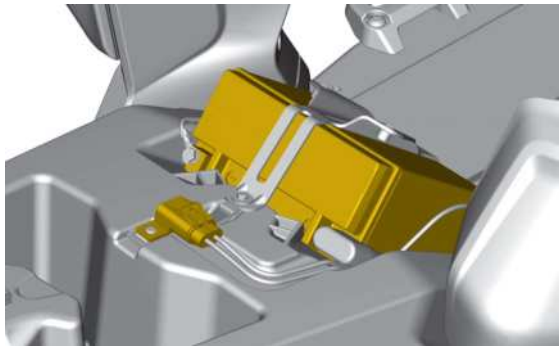



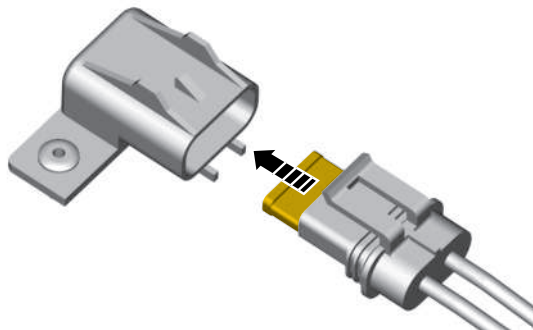

Refer to *Technical Specification* for relay and fuse identification.

## Fuse Inspection

Check the fuse condition and replace it if necessary.

To remove the fuse from the holder, pull the fuse out. Check if the filament is melted.

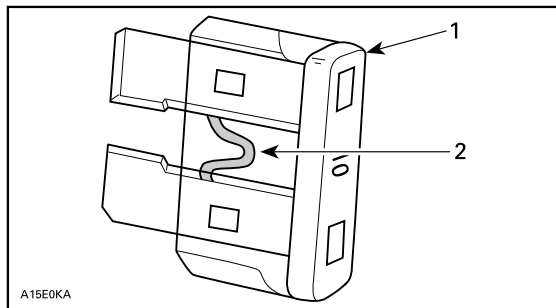

1. Fuse
2. Check if melted

 **WARNING**

Do not use a higher rated fuse.

**⚠ WARNING**

If a fuse has burnt out, the source of the malfunction should be determined and corrected before restarting. See an authorized BRP snowmobile dealer for servicing.

## Headlights

Vehicle Deactivation  
Level:



See *Vehicle Deactivation Classification* for more information.

## Headlight Beam Aiming

Open the storage compartment.

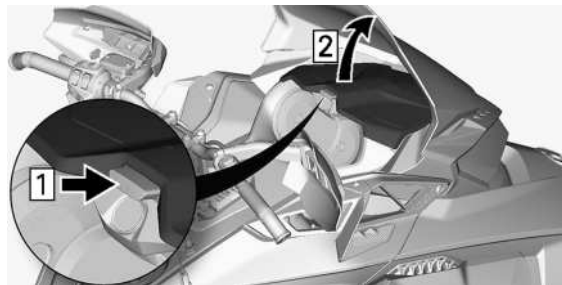

**Typical**

Turn the adjustment screw to reach desired beam height.

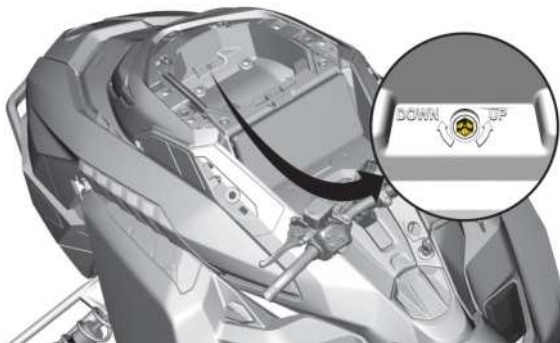

## 12V Battery

Vehicle Deactivation Level:



See *Vehicle Deactivation Classification* for more information.

### WARNING

Never charge or boost the battery while it is installed on the vehicle.

### NOTICE

If the 12V battery voltage is low, it may need to be recharged or replaced in order to start the vehicle.

## Removing the 12V Battery

1. Remove the seat.
2. Remove the battery cover.

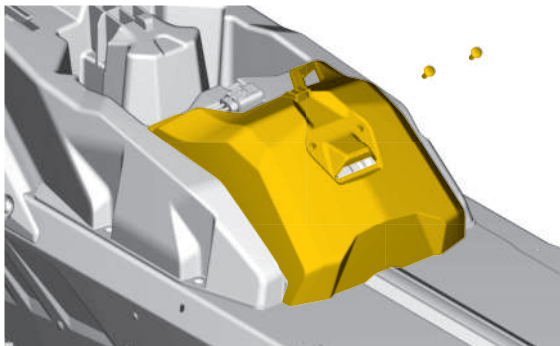

typical

3. Disconnect the negative terminal first, then the positive terminal.

### NOTICE

Battery BLACK ( - ) cable must always be disconnected first and connected last.

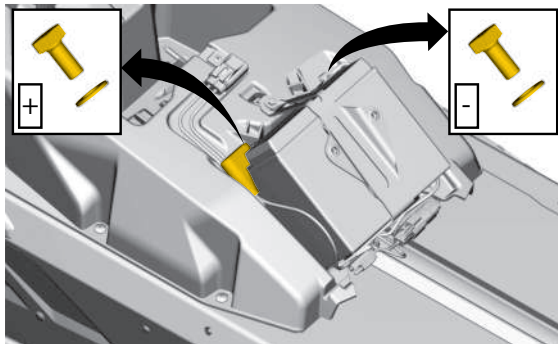

4. Remove the battery hold down bracket.

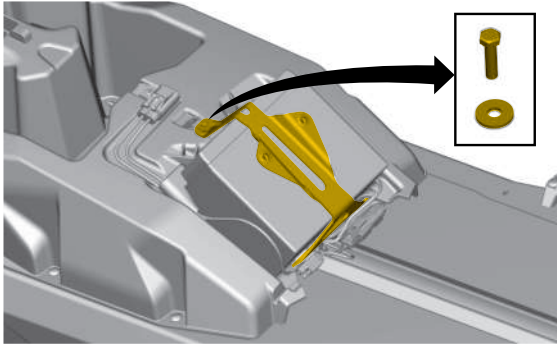

5. Remove the battery.

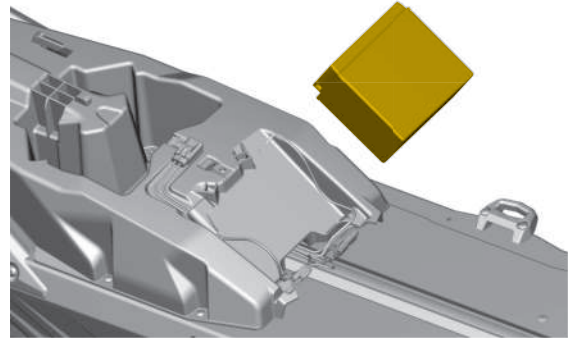

## Cleaning the 12V Battery

Clean the battery casing and battery posts using a soft brush and a solution of baking soda and water.

Remove corrosion from battery cable terminals and battery posts using a firm wire brush.

Rinse with clear water then dry well.

## Charging the 12V Battery

Use any automotive type battery charger. Always refer to the battery charger manufacturer's instructions.

## Installing the 12V Battery

### NOTICE

Battery BLACK ( - ) cable must always be disconnected first and connected last.

The installation is the reverse of the removal procedure. Tighten to the specified torque.

<b>TIGHTENING TORQUE</b>	
Battery terminals (positive and negative)	$6 \pm 0.5 \text{ Nm}$ ( $53 \pm 4 \text{ lbf-in}$ )
Battery hold down bracket	$5 \pm 0.5 \text{ Nm}$ ( $44 \pm 4 \text{ lbf-in}$ )
Battery cover retaining screws	$1.5 \pm 0.5 \text{ Nm}$ ( $13 \pm 4 \text{ lbf-in}$ )

## VEHICLE CARE

### Post-Operation Care

Remove snow and ice from rear suspension, track, front suspension, steering mechanism and skis.



#### WARNING

Make sure the D.E.S.S. key is removed from the vehicle shut-off switch before standing in front the vehicle, or getting close to the track or rear suspension components.

Always cover your snowmobile when leaving it outside overnight or during extended periods of inactivity. This will protect it from frost and snow as well as help retain its appearance.

Avoid leaving your snowmobile in temperatures above 40° C (104° F) or below -20° C (-4° F). The heater and coolant pump will maintain the battery optimal temperature when the vehicle is connected to an EVSE. Never let vehicle fully discharged after a ride, a minimum state of charge of 30% shall be kept to avoid depleting completely the high-voltage battery energy.

### Vehicle Cleaning and Protection

Wash snowmobile using water mixed with a mild detergent.

Use only microfiber cloths or equivalent.

#### NOTICE

Never use a high pressure washer to clean the vehicle. Use **low pressure only**, like a garden hose.

## Non-Compatible Cleaning Products

<i>Material Type</i>	<i>Non-Compatible Cleaning Products</i>
All plastics, vinyls, painted steel and aluminium	BRAKE AND PARTS CLEANER OR ANY PETROLEUM BASE CLEANING PRODUCTS

## Compatible Cleaning Products

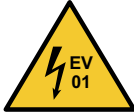
Vehicle Deactivation Level:	
-----------------------------	---

Refer to *Vehicle Deactivation Classification* for more information.

<i>Material Type</i>	<i>Cleaning Product</i>
All plastics, vinyls, painted steel and aluminium.	Automotive type soap with water XPS Spray Cleaner and Polish XPS All Purpose Cleaner

For more information and products, Visit the XPS Products website at [www.xpslubricants.com](http://www.xpslubricants.com)



## STORAGE

Proper storage is necessary when a snowmobile is not in use for more than three months.

When planning on storing the vehicle for more than 90 days, there are steps you can take to maintain the longevity of the high-voltage battery.

Store the vehicle in a cool and dry environment. The recommended storage temperature is 0° C to 45° C (32° F to 113° F).

It is best not to begin long term storage when the high-voltage battery is at 100% state of charge. Rather, try to begin storage with the charge level at approximately 45%. Keep in mind that the battery will slowly drain while not being used. During storage, check the level monthly to ensure that it has not fallen below 20%. If this occurs, charge the battery until it reaches 45%.

### NOTICE

Vehicles stored during cold temperatures may require the vehicle to be connected for a longer period of time before riding.

When the storage period has ended, it is best to charge the vehicle to 70% state of charge before the first use.

---

## Storage

Clean the vehicle

Lubricate the brake lever pivot

Lubricate the rear suspension

Charge the 12V battery monthly to keep it fully charged during storage (this can be done with a trickle charger if necessary)

Charge the high-voltage propulsion battery monthly to maintain between 30% and 60% percent charge during storage

Lift the rear of vehicle until track is clear of the ground. Do not release track tension



### CAUTION

Use appropriate lifting device or have assistance to share lifting stress. If a lifting device is not used, use proper lifting techniques, including lifting with your legs. Do not attempt to lift the rear of vehicle if it is above your limits.

### NOTICE

The snowmobile has to be stored in a cool and dry place and covered with an opaque but ventilated tarpaulin. This will prevent sun rays and grime from affecting plastic components and vehicle finish. The Recommended storage temperature is 0° C to 45° C (32° F to 113° F). If required, the vehicle can be temporarily stored at temperature between -40° C to 40° C (-40° F to 104° F).

---

## **PRESEASON PREPARATION**

Proper vehicle preparation is necessary when a vehicle has not been used for more than three months.

Perform the items as directed in the Maintenance Schedule.

Visit your authorized BRP snowmobile dealer for more information.

**MAINTENANCE RECORDS**

Send photocopies of the maintenance records to BRP if needed.

<i>Pre-delivery</i>	
Serial number: _____	Signature/Print:
Km/ Mileage: _____	
Hours: _____	
Date: _____	
Dealer no: _____	
Notes: _____ _____	
Refer to vehicle Pre-Delivery Bulletin for detailed installation procedures	

---

***First inspection***

Km/ Mileage:

Hours:

Date:

Dealer no:

Notes:

Signature/Print:

For maintenance schedule refer to Maintenance Information section of this operator's guide

***Service***

Km/ Mileage:

Hours:

Signature/Print:

## *Service*

Date:

Dealer no:

Notes:

For maintenance schedule refer to Maintenance Information section of this operator's guide

---

**Service**

Km/ Mileage:

\_\_\_\_\_

Hours:

\_\_\_\_\_

Date:

\_\_\_\_\_

Dealer no:

\_\_\_\_\_

Notes:

\_\_\_\_\_

\_\_\_\_\_

Signature/Print:

For maintenance schedule refer to Maintenance Information section of this operator's guide

**Service**

Km/ Mileage:

\_\_\_\_\_

Hours:

Signature/Print:



## *Service*

Date:

Dealer no:

Notes:

For maintenance schedule refer to Maintenance Information section of this operator's guide

---

**Service**

Km/ Mileage:

\_\_\_\_\_

Hours:

\_\_\_\_\_

Date:

\_\_\_\_\_

Dealer no:

\_\_\_\_\_

Notes:

\_\_\_\_\_

\_\_\_\_\_

Signature/Print:

For maintenance schedule refer to Maintenance Information section of this operator's guide

**Service**

Km/ Mileage:

\_\_\_\_\_

Hours:

Signature/Print:

## *Service*

Date:

Dealer no:

Notes:

For maintenance schedule refer to Maintenance Information section of this operator's guide

---

**Service**

Km/ Mileage:

\_\_\_\_\_

Hours:

\_\_\_\_\_

Date:

\_\_\_\_\_

Dealer no:

\_\_\_\_\_

Notes:

\_\_\_\_\_

\_\_\_\_\_

Signature/Print:

For maintenance schedule refer to Maintenance Information section of this operator's guide

**Service**

Km/ Mileage:

\_\_\_\_\_

Hours:

Signature/Print:

## *Service*

Date:

Dealer no:

Notes:

For maintenance schedule refer to Maintenance Information section of this operator's guide

---

**Service**

Km/ Mileage:

\_\_\_\_\_

Hours:

\_\_\_\_\_

Date:

\_\_\_\_\_

Dealer no:

\_\_\_\_\_

Notes:

\_\_\_\_\_

\_\_\_\_\_

Signature/Print:

For maintenance schedule refer to Maintenance Information section of this operator's guide

**Service**

Km/ Mileage:

\_\_\_\_\_

Hours:

Signature/Print:

## *Service*

Date:

Dealer no:

Notes:

For maintenance schedule refer to Maintenance Information section of this operator's guide

---

**Service**

Km/ Mileage:

\_\_\_\_\_

Hours:

\_\_\_\_\_

Date:

\_\_\_\_\_

Dealer no:

\_\_\_\_\_

Notes:

\_\_\_\_\_

\_\_\_\_\_

Signature/Print:

For maintenance schedule refer to Maintenance Information section of this operator's guide

**Service**

Km/ Mileage:

\_\_\_\_\_

Hours:

Signature/Print:



## *Service*

Date:

Dealer no:

Notes:

For maintenance schedule refer to Maintenance Information section of this operator's guide

---

**Service**

Km/ Mileage:

\_\_\_\_\_

Hours:

\_\_\_\_\_

Date:

\_\_\_\_\_

Dealer no:

\_\_\_\_\_

Notes:

\_\_\_\_\_

\_\_\_\_\_

Signature/Print:

For maintenance schedule refer to Maintenance Information section of this operator's guide

**Service**

Km/ Mileage:

\_\_\_\_\_

Hours:

Signature/Print:

## *Service*

Date:

Dealer no:

Notes:

For maintenance schedule refer to Maintenance Information section of this operator's guide



## **6** TECHNICAL INFORMATION - TABLE OF CONTENTS

---

<b>VEHICLE IDENTIFICATION</b> .....	<b>6-2</b>
Vehicle Description Decal .....	6-2
Identification Numbers .....	6-3
<b>COMPLIANCE LABELS</b> .....	<b>6-7</b>
SSCC Label .....	6-7
<b>EU DECLARATION OF CONFORMITY</b> .....	<b>6-8</b>
<b>UK DECLARATION OF CONFORMITY</b> .....	<b>6-9</b>
<b>RADIO FREQUENCY DIGITALLY ENCODED SECURITY SYSTEM (RF D.E.S.S. KEY)</b> .....	<b>6-10</b>
<b>MULTIFUNCTION GAUGE REGULATORY INFORMATION</b> .....	<b>6-12</b>

---

## VEHICLE IDENTIFICATION

### Vehicle Description Decal

Vehicle description decal is located on right hand side of tunnel.

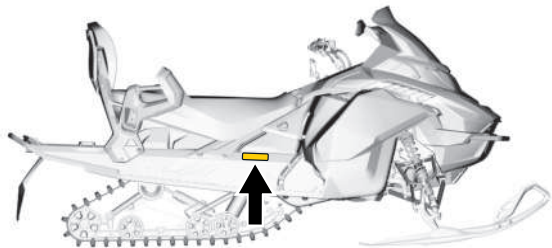

typical



For North American Market

### Identification Numbers

The main components of your snowmobile (high-voltage propulsion system and frame) are identified by different identification numbers. It may sometimes become necessary to locate these numbers for warranty purposes or to trace your snowmobile in the event of loss. These numbers are required by the authorized BRP snowmobile dealer to complete

warranty claims properly. We strongly recommend that you take note of all the identification numbers on your snowmobile and supply them to your insurance company.

---

## High-Voltage Battery Identification Number Location

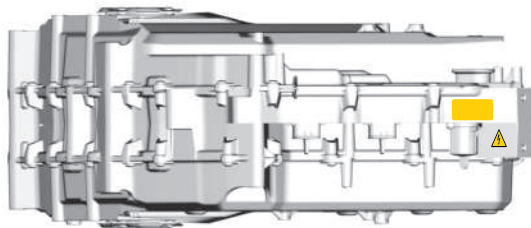



P/N:

S/N:

361VDC 8,9kWh Li-ion



Bombardier Recreational  
Products Inc

Fabriqué au Canada  
Made in Canada

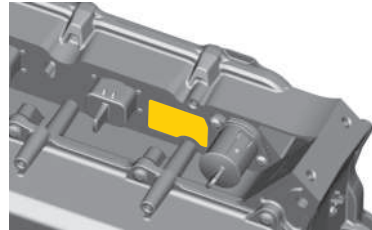

6

## High Voltage Battery Identification Label

---

## Vehicle Identification Number (VIN)

VIN is scribed on vehicle description decal. See above. It is also engraved on tunnel near vehicle description decal.

Model number and model year are part of the information found in the VIN. See illustration.

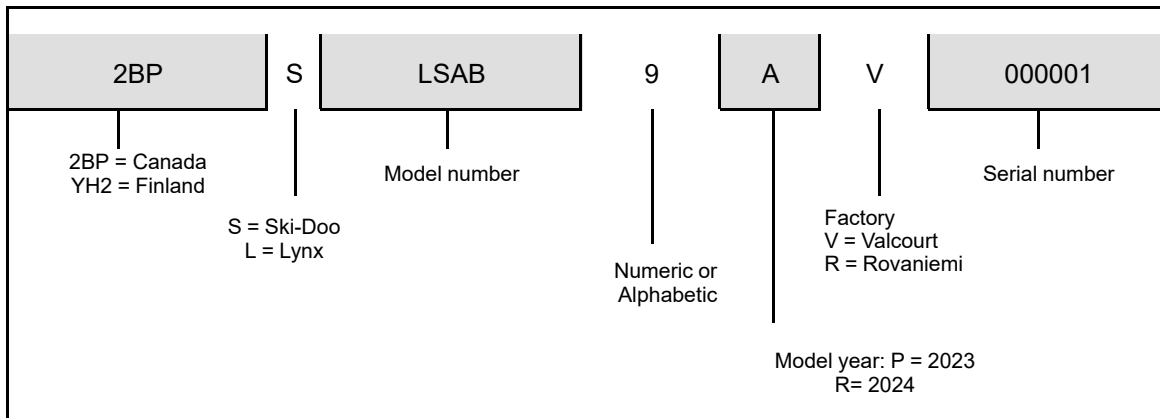

## COMPLIANCE LABELS

### SSCC Label

Safety standards for snowmobiles have been adopted by the Snowmobile Safety and Certification Committee (SSCC) of which BRP is a proud participating member. Assure that your snowmobile meets these standards by locating the Certification Label on the right vertical portion of the vehicle.

The following label shows that an independent testing laboratory has verified compliance with the SSCC safety standards.

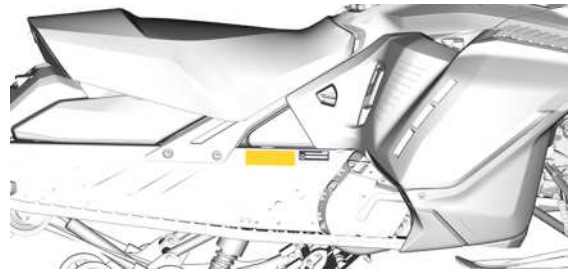

Typical

6

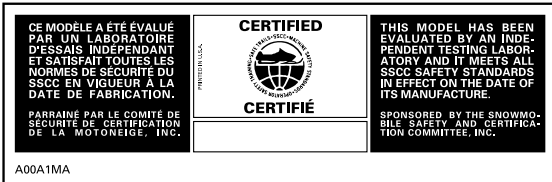

SSCC Label

# EU DECLARATION OF CONFORMITY



Modulo Europeo per  
la Dichiarazione di  
Conformità (MDD) 2015/1004  
Rev. 01/2015

www.bsp.com

## EU Declaration of Conformity

**Authorized Representative:** BRP-Rolax GmbH Co. KG, Rolaxstrasse 1, Gamskirchen, A-4623, Austria

This declaration of conformity is issued under the sole responsibility of the manufacturer.

The undersigned, representing the manufacturer, hereby declares that model year 2025 Electric Snowmobiles marked with the **CE** mark and a 17-character vehicle identification number (VIN) structured as YHXXXXXXXXXXXX under commercial names Ski-Doo or Lynx comply with all the relevant provisions of the following Directives and Regulations:

Machinery Directive 2006/42/EC as amended up to and including Reg. 2019/1243/EU	ISO 12100:2010
Electromagnetic Compatibility (EMC) Directive 2014/53/EU as amended up to and including Reg. (EU) 2018/1139	CISPR 12:2007/A1:2009 & IEC 61000-6-1:2008 or UN R10.04 or later version
Battery Directive 2023/1542 as amended up to and including Dir. (EU) 2019/1020	EN 50342-7:2015
Radio Equipment (RED) Directive 2014/53/EU as amended up to and including Reg. 2023/1717 (if fitted with radio frequency (RF) D.E.S. key)	IEC 62368-1:2014 CISPR 25:2016 ISO 11452-2:2004 ETSI EN 300 330 V2.1:2017

*Dominic Tessier*

Dominic Tessier (CA) CA, 2024 (M 4371)

Dominic Tessier, Eng  
Director, Vehicle Engineering, Ski-Doo  
Bombardier Recreational Products Inc.

Valcourt, QC, Canada

Jun 24, 2024

BRP-Rolax GmbH Co. KG, Rolaxstrasse 1, Gamskirchen, A-4623, Austria

# UK DECLARATION OF CONFORMITY



Edwin Chapman & Co  
UK  
Chartered Accountants  
Crested  
www.bpp.com

## UK Declaration of Conformity

**Authorized Representative:** BRP Recreational Products UK Ltd., (BMM Accountants Limited), Suite 5.1, 12 Tithebarn Street, Liverpool, L2 2DT

This declaration of conformity is issued under the sole responsibility of the manufacturer.

The undersigned, representing the manufacturer, hereby declares that model year 2025 Electric Snowmobiles marked with the  mark and a 17-character vehicle identification number (VIN) structured as YH2xxxxxSRxxxxx under commercial names Ski-Doo or Lynx comply with all the relevant provisions of the following Directives and Regulations:

Machinery Directive 2006/42/EC as amended up to and including Reg. 2018/1243/EU	ISO 12100:2010
Electromagnetic Compatibility (EMC) Directive 2014/30/EU as amended up to and including Reg. (EU) 2018/1139	CISPR 12:2007/A1:2009 & IEC 61000-6-1:2005 or UN E10.04 or later version
Battery Directive 2006/42/EC as amended up to and including Dir. (EU) 2018/1020	EN 50342-7:2015
Radio Equipment (RED) Directive 2014/53/EU as amended up to and including Reg. 2023/1717 (if fitted with radio frequency (RF) D.E.S. key)	IEC 62368-1:2014 CISPR 25:2016 ISO 11453-2:2004 ETSI EN 300 330 V2.1.1:2017

*Dominic Tessier*

Signature of the authorized representative

Dominic Tessier, Eng  
Director, Vehicle Engineering, Ski-Doo  
Bombardier Recreational Products Inc.

Valcourt, QC, Canada  
Jun 24, 2024

skidoo.com | 1-877-850-8888 | SUPPORT@SKIDOO.COM | 0000-0000

---

## **RADIO FREQUENCY DIGITALLY ENCODED SECURITY SYSTEM (RF D.E.S.S. KEY)**

This device complies with FCC Part 15 and Industry Canada license exempt RSS standard(s).

Operation is subject to the following two conditions: (1) this device may not cause interference, and (2) this device must accept any interference, including interference that may cause undesired operation of the device.

Changes or modifications not expressly approved by the party responsible for compliance could void the user's authority to operate the equipment.

IC Registration Number: 12006A-1001317030

FCC ID: 2ACER-1001317030

We, the party responsible for compliance, declare under our sole responsibility that the device is in conformity with the provisions of the following Council Directive: 2014/53/EU. To which this declaration relates is in conformity with the essential requirements and other relevant requirements. The product is in conformity with the following directives, harmonized standards and regulations:

Radio Equipment Directive (RED) 2014/53/EU and Harmonized Standards:

IEC 62368-1:2014, CISPR 25:2016, ISO 11452-2:2004, ETSI EN 300 330 V2.1.1:2017

Radio Equipment Statutory Instrument 2017/1206 and Designated Standards:

IEC 62368-1:2014, CISPR 25:2016, ISO 11452-2:2004, ETSI EN 300 330 V2.1.1:2017

---

## MULTIFUNCTION GAUGE REGULATORY INFORMATION

### Technical Information

#### Transmitter:

- BT operating frequency range: 2402 - 2480 MHz
- BT version: 5.0
- BT max transmit power: +8 dBm

### Manufacturer and Address

#### Manufacturer:

- Enovation Controls LLC

#### Address:

- 5311 S 122nd E. Ave. Tulsa,  
OK 74146,  
USA

To display the regulatory information on the vehicle digital display: From the home screen, access the main menu and keep the joystick pressed down for more than 10 seconds.



### USA and Canada

This device complies with FCC Part 15 and Industry Canada license exempt RSS standard(s). Operation is subject to the following two conditions:

- (1) this device may not cause interference, and
- (2) this device must accept any interference, including interference that may cause undesired operation of the device.

L'émetteur/récepteur exempt de licence contenu dans le présent appareil est conforme aux CNR d'Innovation, Sciences et Développement économique Canada applicables aux appareils radio exempts de licence. L'exploitation est autorisée aux deux conditions suivantes:

- (1) l'appareil ne doit pas produire de brouillage, et
- (2) l'appareil doit accepter tout brouillage radioélectrique subi, même si le brouillage est susceptible d'en compromettre le fonctionnement.

Changes or modifications not expressly approved by the party responsible for compliance could void the user's authority to operate the equipment.

IC: 28102-ECB01

FCC ID: 2A3FV-ECB01

---

RF exposure:

1. The equipment complies with FCC RF exposure limits set forth for an uncontrolled environment.
2. This equipment must be installed and operated with a separation distance of at least 20 cm from all persons.
3. The antenna(s) used for this transmitter must not be co-located or operating in conjunction with any other antenna or transmitter.

Mexico

IFETEL

Marca: Enovation Controls LLC

Número: RCPENOD22-2195

Modelo: OD1025-01

NOM-208-SCFI-2016 (Disposición Técnica IFT-008-2015)

La operación de este equipo está sujeta a las siguientes dos condiciones:

1. es posible que este equipo o dispositivo no cause interferencia perjudicial y
2. este equipo o dispositivo debe aceptar cualquier interferencia, incluyendo la que pueda causar su operación no deseada.

Brazil



---

Este equipamento não tem direito à proteção contra interferência prejudicial e não pode causar interferência em sistemas devidamente autorizados. Para maiores informações, consulte o site da ANATEL.

#### Japan

This device is granted pursuant to the Japanese Radio Law (電波法) and the Japanese Telecommunications Business Law (電気通信事業法). This device should not be modified (otherwise the granted designation number will become invalid).

#### Europe

#### **Declaration of Conformity**

Simplified EU Declaration of Conformity according Radio Equipment Directive 2014/53/EU



DE

Hiermit erklärt Enovation Controls LLC, dass der Funkanlagentyp OD1025-01 der Richtlinie 2014/53/EU entspricht.

Der vollständige Text der EU-Konformitätserklärung ist unter der folgenden Internetadresse verfügbar:

<https://www.brp.com/en/sustainability/product-responsibility.html>

FR

Le soussigné, Enovation Controls LLC, déclare que l'équipement radioélectrique du type OD1025-01 est conforme à la directive 014/53/UE.

Le texte complet de la déclaration UE de conformité est disponible à l'adresse internet suivante:

<https://www.brp.com/en/sustainability/product-responsibility.html>

BG

С настоящото Enovation Controls LLC декларира, че този тип радиосъоръжение OD1025-01 е в съответствие с Директива 2014/53/ЕС.

Цялостният текст на ЕС декларацията за съответствие може да се намери на следния интернет адрес:

<https://www.brp.com/en/sustainability/product-responsibility.html>

EL

Με την παρούσα ο/η Enovation Controls LLC, δηλώνει ότι ο ραδιοεξοπλισμός OD1025-01 πληροί την οδηγία 2014/53/ΕΕ.

Το πλήρες κείμενο της δήλωσης συμμόρφωσης ΕΕ διατίθεται στην ακόλουθη ιστοσελίδα στο διαδίκτυο:

<https://www.brp.com/en/sustainability/product-responsibility.html>

CS

Timto Enovation Controls LLC prohlašuje, že typ rádiového zařízení OD1025-01 je v souladu se směrnicí 2014/53/EU.

Úplné znění EU prohlášení o shodě je k dispozici na této internetové adrese:

<https://www.brp.com/en/sustainability/product-responsibility.html>

DA

Hermed erklærer Enovation Controls LLC, at radioudstyrstypen OD1025-01 er i overensstemmelse med direktiv 2014/53/EU.

EU-overensstemmelseserklæringens fulde tekst kan findes på følgende internetadresse:

<https://www.brp.com/en/sustainability/product-responsibility.html>

ET

Käesolevaga deklareerib Enovation Controls LLC, et käesolev raadioseadme tüüp OD1025-01 vastab direktiivi 2014/53/EL nõuetele.

EU vastavusdeklaratsiooni täielik tekst on kätesaadav järgmisel internetiaadressil: <https://www.brp.com/en/sustainability/product-responsibility.html>

ES

Por la presente, Enovation Controls LLC declara que el tipo de equipo radioeléctrico OD1025-01 es conforme con la Directiva 2014/53/UE.

El texto completo de la declaración UE de conformidad está disponible en la dirección Internet siguiente:

<https://www.brp.com/en/sustainability/product-responsibility.html>

FI

Enovation Controls LLC vakuuttaa, että radiolaitetyypin OD1025-01 on direktiivin 2014/53/EU mukainen. EU-vaatimustenmukaisuusvakuutuksen täysimittainen teksti on saatavilla seuraavassa internetosoitteessa:

<https://www.brp.com/en/sustainability/product-responsibility.html>

EN

Hereby, Enovation Controls LLC declares that the radio equipment type OD1025-01 is in compliance with Directive 2014/53/EU.

The full text of the EU declaration of conformity is available at the following internet address:

<https://www.brp.com/en/sustainability/product-responsibility.html>

HR

Enovation Controls LLC ovime izjavljuje da je radijska oprema tipa OD1025-01 u skladu s Direktivom 2014/53/EU. Cjeloviti tekst EU izjave o sukladnosti dostupan je na sljedećoj internetskoj adresi:

<https://www.brp.com/en/sustainability/product-responsibility.html>

HU

Enovation Controls LLC igazolja, hogy a OD1025-01 típusú rádióberendezés megfelel a 2014/53/EU irányelvnek. Az EU-megfelelőségi nyilatkozat teljes szövege elérhető a következő internetes címen:

<https://www.brp.com/en/sustainability/product-responsibility.html>

IT

Il fabbricante, Enovation Controls LLC, dichiara che il tipo di apparecchiatura radio OD1025-01 è conforme alla direttiva 2014/53/UE.

Il testo completo della dichiarazione di conformità UE è disponibile al seguente indirizzo Internet:

<https://www.brp.com/en/sustainability/product-responsibility.html>

LT

Aš, Enovation Controls LLC, patvirtinu, kad radijo įrenginių tipas OD1025-01 atitinka Direktyvą 2014/53/ES.

Visas ES atitikties deklaracijos tekstas prieinamas šiuo interneto adresu:  
<https://www.brp.com/en/sustainability/product-responsibility.html>

LV

Ar šo Enovation Controls LLC deklarē, ka radioiekārtā OD1025-01 atbilst Direktīvai 2014/53/ES. Pilns ES atbilstības deklarācijas teksts ir pieejams šādā interneta vietnē: <https://www.brp.com/en/sustainability/product-responsibility.html>

MT

B'dan, Enovation Controls LLC, niddikjara li dan it-tip ta' taghmir tar-radju OD1025-01 huwa konformi mad-Direttiva 2014/53/UE. It-test kollu tad-dikjaraz-zjoni ta' konformità tal-UE huwa disponibbli f'dan l-indirizz tal-Internet li gej: <https://www.brp.com/en/sustainability/product-responsibility.html>

NL

Hierbij verklaar ik, Enovation Controls LLC, dat het type radioapparaatuur OD1025-01 conform is met Richtlijn 2014/53/EU.

De volledige tekst van de EU-conformiteitsverklaring kan worden geraadpleegd op het volgende internetadres:

<https://www.brp.com/en/sustainability/product-responsibility.html>

PL

Enovation Controls LLC niniejszym oświadczam, że typ urządzenia radiowego OD1025-01 jest zgodny z dyrektywą 2014/53/UE.

Pełny tekst deklaracji zgodności UE jest dostępny pod następującym adresem internetowym:

<https://www.brp.com/en/sustainability/product-responsibility.html>

PT

O(a) abaixo assinado(a) Enovation Controls LLC declara que o presente tipo de equipamento de rádio OD1025-01 está em conformidade com a Diretiva 2014/53/UE. O texto integral da declaração de conformidade está disponível no seguinte endereço de Internet:

<https://www.brp.com/en/sustainability/product-responsibility.html>

RO

Prin prezenta, Enovation Controls LLC declară că tipul de echipamente radio OD1025-01 este în conformitate cu Directiva 2014/53/UE.

Textul integral al declarației UE de conformitate este disponibil la următoarea adresă internet:

<https://www.brp.com/en/sustainability/product-responsibility.html>

SV

Härmed försäkras Enovation Controls LLC att denna typ av radioutrustning OD1025-01 överensstämmer med direktiv 2014/53/EU.

Den fullständiga texten till EU-försäkras om överensstämmelse finns på följande webbadress:

<https://www.brp.com/en/sustainability/product-responsibility.html>

SL

Enovation Controls LLC potrjuje, da je tip radijske opreme OD1025-01 skladen z Direktivo 2014/53/EU. Celotno besedilo izjave EU o skladnosti je na voljo na naslednjem spletnem naslovu:

<https://www.brp.com/en/sustainability/product-responsibility.html>

SK

Enovation Controls LLC týmto vyhlasuje, že rádiové zariadenie typu OD1025-01 je v súlade so smernicou 2014/53/EÚ.

Úplné EU vyhlásenie o zhode je k dispozícii na tejto internetovej adrese: <https://www.brp.com/en/sustainability/product-responsibility.html>

IS

Enovation Controls LLC lýsir því hér með yfir að þráðlaus fjarskiptabúnaðurinn OD1025-01 er í samræmi við tilskipun 2014/53/ESB.

Óstytta texta ESB-samræmisyfirlýsingarinnar er að finna á veffanginu: <https://www.brp.com/en/sustainability/product-responsibility.html>

Liechtenstein

Hiermit erkläre Enovation Controls LLC, dass der Funkanlagentyp OD1025-01 der Richtlinie 2014/53/EU entspricht.

Der vollständige Text der EU-Konformitätserklärung ist unter der folgenden Internetadresse verfügbar:

<https://www.brp.com/en/sustainability/product-responsibility.html>

NO

Hermed erklærer Enovation Controls LLC at radioustyrstypen OD1025-01 er i samsvar med direktiv 2014/53/EU.

Hele teksten i EU-samsvarserklæringen finnes på følgende internetadresse: <https://www.brp.com/en/sustainability/product-responsibility.html>

RU

Компания Enovation Controls LLC настоящим заявляет, что радиотехническое оборудование категории OD1025-01 отвечает требованиям Директивы 2014/53/EU. Полный текст декларации соответствия ЕС доступен на сайте

<https://www.brp.com/en/sustainability/product-responsibility.html>

## **7** TECHNICAL SPECIFICATIONS - TABLE OF CONTENTS

---

GRAND TOURING ELECTRIC .....7-2

EXPEDITION ELECTRIC .....7-11

## GRAND TOURING ELECTRIC

Because of our ongoing commitment to product quality and innovation, BRP reserves the right, at any time, to make changes in design and specifications and/or to make additions to, or improvements in its products without imposing any obligation upon itself to install them on its previously manufactured products.

<b>HIGH-VOLTAGE POWER UNIT</b>			
Charging Port Connector	North America	Type 1 – SAE J1772	
E-Motor	Motor type	ROTAX® E-POWER, Liquid-cooled	
	Heat Management	Liquid Cooled	
	Current	High-Voltage 3-phased AC	
	Power	Peak	35 kW
		Continuous	20 kW
Torque		72 Nm (53 lbs-ft) 0 – 4600 RPM	



# TECHNICAL SPECIFICATIONS

<b>HIGH-VOLTAGE POWER UNIT</b>			
	Top speed	Standard Key	60 km/h (37 MPH)
		Learning Key	40 km/h (25 MPH)
High-Voltage Heater		Heat Management	Liquid Cooled
		Input Voltage @ Power	120 Vac @ 300W 240 Vac @ 1200W
High-Voltage Battery		Battery Type	Integrated Lithium-Ion
		Heat Management	Liquid Cooled
		Capacity	8,9 kWh
		Range	50 km
		Mass (dry)	58 kg (128 lb)
Inverter		Heat Management	Liquid Cooled

**HIGH-VOLTAGE POWER UNIT**

	Input Current - E-Motor (Regen)	High-Voltage 3-phased AC
	Input Current - High-Voltage Battery	High-Voltage DC
	Output Current - E-Motor	High-Voltage 3-phased AC
	Output Current - High-Voltage Battery (Regen)	High-Voltage DC
On-Board Charger	Heat Management	Liquid Cooled
	Input Voltage	120 and 240 VAC
	Power	6,6 kW
	Charging time	1.5 h for 10-80% Less than 3 hrs for 0-100%

## TECHNICAL SPECIFICATIONS

<b>COOLING SYSTEM</b>		
Coolant type	Recommended	XPS Extended life pre-mixed coolant
	Alternative, or if not available	Ethyl glycol and distilled water (50%/50%) or coolant specifically formulated for electric vehicles
Quantity	Without radiator	5.9 l (6.2 qt (US))

<b>ELECTRICAL SYSTEM – LOW VOLTAGE</b>			
12V Battery		12 V, 18 A•h	
Headlamp		18.4 W / 42.7 W LED	
Taillight and stoplight		2.6 W / 139 mW LED	
Fuses	FA	Main Fuse	20 A
	F1	Start / Relays	5 A

---

**ELECTRICAL SYSTEM – LOW VOLTAGE**

	F2	Accessories	15 A
	F3	Taillight / Brake / PAC	10 A
	F4	VCU / RFID / Wake-Up	10 A
	F7	Heater valve / Cooling pump	10 A
	F8	Cluster	15 A
	F10	Headlamps	20 A
Relays	RY1	Main	-
	RY2	Accessories	-
	RY3	Fan	-
	RY4	Lighting	-

## TECHNICAL SPECIFICATIONS

<b>DRIVE SYSTEM — CHAINCASE</b>			
Chaincase oil	Type	Recommended	XPS Synthetic gearcase oil
		Alternative, or if not available	75W140 gear oil that meets the API GL-5 specification
	Capacity	350 ml (11.8 fl oz (US))	
Chain drive ratio		First chain: 19/43	
		Second chain: 23/53	

<b>DRIVE SYSTEM — TRACK</b>			
Drive sprocket number of teeth		Grand Touring Sport - EV	8
Track	Width		35.5 cm (14 in)
	Length		305 cm (120 in)

**DRIVE SYSTEM — TRACK**

	Profile height	19 mm (0.75 in)
Track adjustment <sup>(1)</sup>	Deflection	42 mm (1.65 in)
	Force	4.54 kgf (10 lbf)

<sup>(1)</sup> Refer to *Track Tension Verification in Maintenance Procedures* for detailed procedure.

**BRAKE SYSTEM**

Brake	Type	Single 200-mm cross-drilled carbon steel disc
Brake fluid	Type	DOT 4
	Quantity	65 ml (2.2 fl oz (US))
Caliper		Fixed twin pistons (2 x 40 mm)
Brake pad material		Organic

## TECHNICAL SPECIFICATIONS

<b>BRAKE SYSTEM</b>	
Minimum brake pad thickness (includes backing plate)	5 mm (.197 in)
Minimum brake disc thickness	4.5 mm (.177 in)
Maximum brake disc warpage	0.25 mm (.01 in)

<b>FRONT SUSPENSION</b>	
Suspension type	RAS X
Suspension maximum travel	225 mm (8.9 in)
Shock absorber type	Motion Control

<b>REAR SUSPENSION</b>	
Suspension type	Revised SC-5
Suspension maximum travel Measured at rear arm	250 mm (9.8 in)

---

<b>REAR SUSPENSION</b>		
Shock absorber type	Center	Motion Control
	Rear	KYB 36

<b>WEIGHT AND DIMENSIONS</b>	
Mass (dry)	240.9 kg (530 lb)
Overall length	292,5 cm (115.2 in)
Overall width	121.7 cm (47.9 in)
Overall height	151.3 cm (59.6 in)
Ski stance	109 cm (43 in)
Cargo load	15.8 kg (35 lb)



## EXPEDITION ELECTRIC

Because of our ongoing commitment to product quality and innovation, BRP reserves the right, at any time, to make changes in design and specifications and/or to make additions to, or improvements in its products without imposing any obligation upon itself to install them on its previously manufactured products.

<b>HIGH-VOLTAGE POWER UNIT</b>			
Charging Port Connector	North America	Type 1 – SAE J1772	
E-Motor	Motor type	ROTAX® E-POWER, Liquid-cooled	
	Heat Management	Liquid Cooled	
	Current	High-Voltage 3-phased AC	
	Power	Peak	35 kW
		Continuous	20 kW
Torque		72 Nm (53 lbs-ft) 0 – 4600 RPM	

<b>HIGH-VOLTAGE POWER UNIT</b>			
	Top speed	Standard Key	60 km/h (37 MPH)
High-Voltage Heater	Heat Management		Liquid Cooled
	Input Voltage @ Power		120 Vac @ 300W 240 Vac @ 1200W
High-Voltage Battery	Battery Type		Integrated Lithium-Ion
	Heat Management		Liquid Cooled
	Capacity		8,9 kWh
	Range		Up to 30 km (18.6 mi)
	Mass (dry)		58 kg (128 lb)
Inverter	Heat Management		Liquid Cooled
	Input Current - E-Motor (Regen)		High-Voltage 3-phased AC

## TECHNICAL SPECIFICATIONS

<b>HIGH-VOLTAGE POWER UNIT</b>		
	Input Current - High-Voltage Battery	High-Voltage DC
	Output Current - E-Motor	High-Voltage 3-phased AC
	Output Current - High-Voltage Battery (Regen)	High-Voltage DC
On-Board Charger	Heat Management	Liquid Cooled
	Input Voltage	120 and 240 VAC
	Power	6,6 kW
	Charging time	1.5 h for 10-80% Less than 3 hrs for 0-100%

<b>COOLING SYSTEM</b>		
Coolant type	Recommended	XPS Extended life pre-mixed coolant

<b>COOLING SYSTEM</b>		
	Alternative, or if not available	Ethyl glycol and distilled water (50%/50%) or coolant specifically formulated for electric vehicles
Quantity	Without radiator	5.9 l (6.2 qt (US))

<b>ELECTRICAL SYSTEM – LOW VOLTAGE</b>			
12V Battery		12 V, 18 A•h	
Headlamp		18.4 W / 42.7 W LED	
Taillight and stoplight		2.6 W / 139 m W LED	
Fuses	FA	Main Fuse	20 A
	F1	Start / Relays	5 A
	F2	Accessories	15 A

## TECHNICAL SPECIFICATIONS

### ELECTRICAL SYSTEM – LOW VOLTAGE

	F3	Taillight / Brake / PAC	10 A
	F4	VCU / RFID / Wake-Up	10 A
	F7	Heater valve cooling pump	10 A
	F8	Cluster	20 A
	F10	Headlamps	15 A
Relays	RY1	Main	-
	RY2	Accessories	-
	RY3	Lighting	-

### DRIVE SYSTEM — CHAINCASE

Chaincase oil	Type	Recommended	XPS Synthetic gearcase oil
		Alternative, or if not available	75W140 gear oil that meets the API GL-5 specification

**DRIVE SYSTEM — CHAINCASE**

	Capacity	350 ml (11.8 fl oz (US))
Chain drive ratio		First chain: 19/43
		Second chain: 23/53

**DRIVE SYSTEM — TRACK**

Drive sprocket number of teeth	Expedition - EV	8
Track	Width	38.1 cm (15 in)
	Length	348 cm (137 in)
	Profile height	25.4 mm (1.6 in)
Track adjustment <sup>(1)</sup>	Deflection	40 mm (1.57 in)

## TECHNICAL SPECIFICATIONS

### **DRIVE SYSTEM — TRACK**

	Force	4.54 kgf (10 lbf)
--	-------	-------------------

(1) Refer to *Track Tension Verification in Maintenance Procedures* for detailed procedure.

### **BRAKE SYSTEM**

Brake	Type	Single 200-mm cross-drilled carbon steel disc
Brake fluid	Type	DOT 4
	Quantity	65 ml (2.2 fl oz (US))
Caliper	Fixed twin pistons (2 x 40 mm)	
Brake pad material	Organic	
Minimum brake pad thickness (includes backing plate)	5 mm (.197 in)	

<b><i>BRAKE SYSTEM</i></b>	
Minimum brake disc thickness	4.5 mm (.177 in)
Maximum brake disc warpage	0.25 mm (.01 in)

<b><i>FRONT SUSPENSION</i></b>	
Suspension type	RAS X
Suspension maximum travel	235 mm (9.3 in)
Shock absorber type	Motion Control

<b><i>REAR SUSPENSION</i></b>		
Suspension type		SC-5M
Suspension maximum travel Measured at rear arm		245 mm (9.6 in)
Shock absorber type	Center	Motion Control



## TECHNICAL SPECIFICATIONS

<b>REAR SUSPENSION</b>		
	Rear	KYB 36

<b>WEIGHT AND DIMENSIONS</b>	
Mass (dry)	240.9 kg (530 lb)
Overall length	303.8 cm (119.6 in)
Overall width	121.7 cm (47.9 in)
Overall height	126.7 cm (49.9 in)
Ski stance	109 cm (43 in)
Cargo load	15.8 kg (35 lb)
Towing capacity	260 kg (537 lb)



## **8** TROUBLESHOOTING - TABLE OF CONTENTS

---

<b>TROUBLESHOOTING GUIDELINES – ELECTRIC SNOWMOBILES</b> .....	<b>8-2</b>
<b>MONITORING SYSTEM</b> .....	<b>8-6</b>
Pilot Lamps, Messages and Beeper Codes .....	8-6
Fault Codes .....	8-11

---

## TROUBLESHOOTING GUIDELINES – ELECTRIC SNOWMOBILES

### ***ELECTRIC VEHICLE DOES NOT TURN ON***

- 1. 12V battery is too low.**
  - *A 12V battery charger can be used to charge the battery.*
- 2. Emergency stop switch in OFF position or tether cord cap not installed on the vehicle cut-off switch.**
  - *Place the emergency stop switch in the ON position and install the tether cord cap (on cut-off switch).*
- 3. Vehicle temperature and/or system voltage is too low.**
  - *Connect the vehicle to an Electrical Vehicle Supply Equipment (EVSE) and let the vehicle charging system recharge the high and low voltage battery packs.*
  - *Contact an authorized BRP snowmobile dealer.*
  - *If the high-voltage propulsion battery temperature is below -20° C (-4° F), the system will not charge. If the vehicle is connected to the EVSE, the heater will activate.*

**VEHICLE LACKS ACCELERATION OR POWER**

The  icon is displayed in the cluster when the vehicle is too cold or there is an error with any of the propulsion system components.

**1. High-voltage propulsion system error.**

- *Plug in the vehicle.*
- *Contact an authorized BRP snowmobile dealer.*

**2. High-voltage propulsion system is in limited performance mode.**

- *Check coolant level. Refer to Maintenance Procedures.*
- *Check heat exchangers cleanliness. Clean if necessary.*
- *Check the coolant pump activation under normal and charging operation.*

---

**HEATED GRIPS/THUMB WARMERS ARE NOT WORKING**

**1. High-voltage battery state of charge is too low.**

- *Connect the vehicle to an EVSE.*

**2. Vehicle is connected to an EVSE.**

- *The heated grip/thumb warmer will resume operation when the EVSE is disconnected.*

### **VEHICLE HAS SHUT DOWN**

- 1. Emergency stop switch in OFF position or tether cord cap not installed on vehicle cut-off switch.**
  - *Place the emergency stop switch in the ON position and install the tether cord cap (on cut-off switch).*
- 2. Vehicle temperature and/or system voltage is too low.**
  - *Connect the vehicle to an Electrical Vehicle Supply Equipment (EVSE) and let the vehicle charging system recharge the High and Low voltage battery packs.*
  - *Contact an authorized BRP snowmobile dealer.*

## MONITORING SYSTEM

### Pilot Lamps, Messages and Beeper Codes

Gauge pilot lamp (s) will inform you if an anomaly occurs or to inform you of a particular condition.

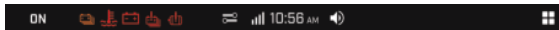

**Digital Pilot Lamp – 10.25” Color Digital Touchscreen**





**Pilot Lamps – 10.25” Color Digital Touchscreen**

A tell-tale can flash alone or in combination with another lamp.



Some messages will be displayed with a beep code and tell-tale(s).

Beeper codes will be heard and messages will be displayed to catch your attention.

<i><b>Pilot lamp ON</b></i>	<i><b>Beep-er</b></i>	<i><b>Message display</b></i>	<i><b>Description</b></i>
	1 long beep	—	The coolant temperature is high.
	—	12V BATTERY / LOW BATTERY VOLTAGE	A low voltage measurement is detected in the 12 volt electrical system.
	—	12V BATTERY / HIGH BATTERY VOLTAGE	A high voltage measurement is detected in the 12 volt electrical system.





## TROUBLESHOOTING



<i>Pilot lamp ON</i>	<i>Beep-er</i>	<i>Message display</i>	<i>Description</i>
	Repetitive short beeps	PARKING BRAKE APPLIED / RELEASE PARKING BRAKE	Displayed when brake is applied for more than 15 seconds while accelerator lever is squeezed and vehicle is moving at more than 5 km/h (3 mph).
	1 long beep	ELECTRICAL FAULT / SERVICE REQUIRED	An electrical fault or high voltage interlock fault is detected.
—	—	CHARGING	A problem is detected with the



<i>Pilot lamp ON</i>	<i>Beep-er</i>	<i>Message display</i>	<i>Description</i>
		SYSTEM / SYSTEM IS UNABLE TO CHARGE	charging system and the charging stops.
	—	CHARGING STATION / VEHICLE IS UNABLE TO CHARGE	A problem is detected with the charging station.
—	—	PROPULSION BATTERY /	System cannot charge due to low temperature

<i>Pilot lamp ON</i>	<i>Beep-er</i>	<i>Message display</i>	<i>Description</i>
		LOW TEMPERATURE - WARM UP MODE	
—	—	PROPULSION BATTERY / HIGH TEMPERATURE - COOLING DOWN	System cannot charge due to high temperature
	Repetitive short beeps	CHARGING STATION / UNABLE	There is a connection problem with the charging cable handle.

<i>Pilot lamp ON</i>	<i>Beep-er</i>	<i>Message display</i>	<i>Description</i>
		TO CHARGE - CHECK CHARGE HANDLE	
	1 short beep	PROPULSION SYSTEM / AUTOMATIC POWER REDUCTION	Limited power mode activated due to system malfunction.
	—	—	There is a failure with the high-voltage propulsion battery.

## TROUBLESHOOTING

<i>Pilot lamp ON</i>	<i>Beep-er</i>	<i>Message display</i>	<i>Description</i>
	—	—	There is a problem with the propulsion system.
	1 long beep	EMERGENCY SHUT-DOWN / PARK IN A SAFE PLACE	Critical condition causing the Vehicle Control Unit (VCU) to order an immediate shutdown
	1 short beep	ELECTRIC MOTOR / OVER-HEAT	The high voltage e-motor internal temperature is above optimal temperature range.

<i>Pilot lamp ON</i>	<i>Beep-er</i>	<i>Message display</i>	<i>Description</i>
	1 long beep	EMERGENCY SHUT-DOWN / PARK NOW AND GET OFF THE VEHICLE	There is a critical failure with the high-voltage propulsion battery and the vehicle will shutdown.
	1 short beep	PROPULSION BATTERY / OVER-HEAT	The high voltage propulsion battery internal temperature is above optimal temperature range
	—	PROPULSION BATTERY /	The high-voltage propulsion battery

<b><i>Pilot lamp ON</i></b>	<b><i>Beep-er</i></b>	<b><i>Message display</i></b>	<b><i>Description</i></b>
		LOW STATE OF CHARGE - CHARGE NOW	has a low state of charge.
DESS	—	—	Good key, vehicle ready to operate.
	—	WRONG KEY	Unable to read key (bad connection). Make sure the key is clean and correctly snapped on post.
	—	CHECK KEY	Invalid key or key not programmed. Use the proper key

<b><i>Pilot lamp ON</i></b>	<b><i>Beep-er</i></b>	<b><i>Message display</i></b>	<b><i>Description</i></b>
			for the vehicle or have the key programmed.
—	Fast repetition	DRIVE DEACTIVATION / PRESS BRAKE TO KEEP VEHICLE ALIVE	The vehicle automatically goes in standby mode when no interactions are detected.

<i>Pilot lamp ON</i>	<i>Beep-er</i>	<i>Message display</i>	<i>Description</i>
—	—	VEHICLE SHUT-DOWN / PRESS BRAKE TO KEEP VEHICLE ON	The vehicle automatically shuts down when no interactions are detected.

## Fault Codes

The fault codes can be displayed on the center display.

The fault codes are accessible in the setting menu.

Contact an authorized BRP snowmobile dealer for code signification.



## **9** WARRANTY - TABLE OF CONTENTS

---

**BRP LIMITED WARRANTY CANADA AND  
USA: 2025 SKI-DOO® ELECTRIC  
SNOWMOBILES .....9-2**

**BRP INTERNATIONAL LIMITED  
WARRANTY: 2025 SKI-DOO® ELECTRIC  
SNOWMOBILES .....9-11**

**BRP LIMITED WARRANTY FOR THE  
EUROPEAN ECONOMIC AND THE  
COMMONWEALTH OF THE INDEPENDENT  
STATES (CIS) AREAS AND TURKEY: 2025  
SKI-DOO® ELECTRIC  
SNOWMOBILES ..... 9-21**

---

# BRP LIMITED WARRANTY CANADA AND USA: 2025 SKI-DOO® ELECTRIC SNOWMOBILES

## 1) SCOPE OF THE LIMITED WARRANTY

Bombardier Recreational Products Inc. (“**BRP**”) warrants its 2025 Ski-Doo electric snowmobiles (the “**Product**”) and its high-voltage batteries sold by authorized BRP dealers in the United States of America (“**USA**”) and in Canada (a “**BRP Dealer**”) from defects in material or workmanship for the period and under the conditions described below.

This limited warranty will become null and void if:

1. The Product was used for racing or any other competitive activity, at any point, even by a previous owner;
2. The Product has been altered or modified in such a way so as to adversely affect its operation, performance or durability, or has been altered or modified to change its intended use;
3. The Product has been altered or modified in such a way so as to adversely affect the high-voltage battery operation, performance or durability;
4. The Product’s high-voltage battery has been used as a stationary power source.

The on-board charger, inverter, and e-motor are covered under the vehicle’s limited warranty period against defects in material or workmanship.



Non-factory installed parts and accessories are not covered under this limited warranty. Please refer to the applicable parts and accessories limited warranty text.

## 2) LIMITATIONS OF LIABILITY

**TO THE EXTENT PERMITTED BY LAW, THIS WARRANTY IS EXPRESSLY GIVEN AND ACCEPTED IN LIEU OF ANY AND ALL OTHER WARRANTIES, EXPRESSED OR IMPLIED, INCLUDING WITHOUT LIMITATION ANY WARRANTY OF MERCHANTABILITY OR FITNESS FOR A PARTICULAR PURPOSE. TO THE EXTENT THAT THEY CANNOT BE DISCLAIMED, THE IMPLIED WARRANTIES ARE LIMITED IN DURATION TO THE LIFE OF THE EXPRESS WARRANTY. INCIDENTAL AND CONSEQUENTIAL DAMAGES ARE EXCLUDED FROM COVERAGE UNDER THIS WARRANTY. SOME STATES/ PROVINCES DO NOT ALLOW FOR THE DISCLAIMERS, LIMITATIONS AND EXCLUSIONS IDENTIFIED ABOVE. AS A RESULT, THEY MAY NOT APPLY TO YOU. THIS WARRANTY GIVES YOU SPECIFIC RIGHTS, AND YOU MAY ALSO HAVE OTHER LEGAL RIGHTS WHICH MAY VARY FROM STATE TO STATE, OR PROVINCE TO PROVINCE.**

Neither the distributor, any BRP Dealer nor any other person has been authorized to make any affirmation, representation or warranty regarding the Product and/or its high-voltage battery, other than those contained in this limited warranty, and if made, shall not be enforceable against BRP.

BRP reserves the right to modify this limited warranty at any time, being understood that such modification will not alter the warranty conditions applicable to the products and/or its high-voltage batteries sold while this warranty is in effect.

---

### **3) EXCLUSIONS – ARE NOT WARRANTED**

This warranty does not cover damage or failures resulting from or caused by:

- Attempting to modify the on-board charger, inverter and/or e-motor, to gain faster charge times or increase the original power output will void the warranty.
- Opening the on-board charger enclosure.
- Opening the inverter enclosure.
- Improper towing or vehicle recovery from a depleted high voltage battery or other failure may damage the e-motor or other high voltage components. Failure to follow the recommended towing and/or recovery method prescribed in this manual will void the warranty.

The following are not warranted under any circumstances:

- Normal wear and tear;
- Routine maintenance items, tune ups, adjustments;
- Damage caused by failure to provide proper maintenance and/or storage, as described in the Operator's Guide;
- Damage resulting from removal of parts, improper repairs, service, maintenance, modifications or use of parts or accessories not manufactured or approved by BRP or resulting from repairs done by a person that is not an authorized servicing BRP Dealer;
- Damage caused by abuse, abnormal use, neglect, use of the product on surfaces other than snow, or operation of the product in a manner inconsistent with the recommended operation described in the Operator's Guide;
- Damage resulting from accident, submersion, fire, theft, vandalism or any act of God;
- Operation with chemicals, oils or lubricants which are not suitable for use with the product (see the Operator's Guide);
- Snow or water ingestion;
- Incidental or consequential damages, or damages of any kind including without limitation towing, storage, telephone, rental, taxi, inconvenience, insurance coverage, loan payments, loss of time, loss of income;

- 
- Damage resulting from studs installed on tracks if the installation does not conform to BRP's instructions;
  - Damage caused by failure to provide proper maintenance and/or storage, as described in the Operator's Guide. Ambient temperatures above 40 °C (104 °F) may damage the high-voltage battery and void the warranty;
  - Damage caused by exposing the high voltage battery to contact with a direct flame;
  - Physical damage to the high voltage battery or intentional attempt to reduce the life of the high voltage battery;
  - Damage to internal components resulting from dis-assembly, opening the high-voltage battery enclosure is strictly forbidden;
  - Damage resulting from incorrect charging procedures or incompatible charging devices;
  - Damage to vehicle's components resulting from a complete discharge of the high-voltage battery.
  - Consequential damage caused by the failure to repair an existing problem;
  - Damage resulting from failure to install a software update;
  - Loss of battery capacity due to or resulting from gradual capacity loss.<sup>(1)</sup>

<sup>(1)</sup>Any capacity/range reduction-based claim must be confirmed by and approved by BRP to be eligible for coverage.

## 4) WARRANTY COVERAGE PERIOD

The vehicle limited warranty will be in effect from (1) the date of delivery to the first retail consumer, or (2) the date the Product is first put into use, whichever occurs first and for the applicable period below:

- **TWELVE (12) consecutive months**, for private use or commercial use owners. However, the warranty coverage period on a snowmobile delivered between June 1<sup>st</sup> and December 1<sup>st</sup> of a given year will expire November 30<sup>th</sup> of the following year.

### *HIGH-VOLTAGE BATTERY*

The high-voltage battery limited warranty will be in effect for TWENTY-FOUR (24) consecutive months, or eight thousand kilometers (8,000 km) / five thousand miles (5,000 mi), whichever occurs first, **only** if the high-voltage battery state of health (SOH) is equal or greater than ( $\geq$ ) seventy percent (70%) of initial capacity.

The repair or replacement of parts or the performance of service under this warranty does not extend the life of this warranty beyond its original expiration date. Loss of battery capacity resulting from gradual capacity loss is NOT covered under this warranty beyond the terms and limit specified above.

---

## 5) CONDITIONS REQUIRED FOR WARRANTY COVERAGE

This warranty coverage is available **only** if each of the following conditions has been fulfilled:

- The Product must be purchased as new and unused by its first owner from a BRP Dealer authorized to distribute the Product in the country in which the sale occurred;
- The BRP specified pre-delivery inspection process must be completed and documented and signed by the purchaser;
- The Product must have undergone proper registration by an authorized BRP Dealer;
- The Product must be purchased in the country in which the purchaser resides; and Routine maintenance outlined in the Operator's Guide must be timely performed in order to maintain warranty coverage. BRP reserves the right to make warranty coverage contingent upon proof of proper maintenance.

BRP will not honor this limited warranty to any owner if one of the preceding conditions has not been met. Such limitations are necessary in order to allow BRP to preserve both the safety of its products, and also that of its consumers and the general public.

## 6) WHAT TO DO TO OBTAIN WARRANTY COVERAGE

The customer and/or commercial operator must cease using the Product upon the appearance of an anomaly, notify a servicing BRP Dealer or BRP directly within three (3) days of the appearance of the anomaly and provide the BRP Dealer with reasonable access to the Product and reasonable opportunity to repair it.

All parts replaced under this limited warranty become the property of BRP.

## 7) WHAT BRP WILL DO

BRP's obligations under this warranty are limited to, at its sole discretion, repairing parts found defective under normal use, maintenance and service, or replacing such parts without charge for parts and labor, at any authorized BRP Dealer during the warranty coverage period under the conditions described herein. No claim of breach of warranty shall be cause for cancellation or rescission of the sale of the Product to the owner.

BRP reserves the right to improve or modify products from time to time without assuming any obligation to modify products previously manufactured.

## 8) TRANSFER

If the ownership of a product is transferred during the warranty coverage period, this limited warranty, subject to its terms and conditions, will NOT be transferred to the new owner.

---

## 9) CONSUMER ASSISTANCE

In the event of a controversy or a dispute in connection with this limited warranty, BRP suggests that you try to resolve the issue at the dealership level. We recommend discussing the issue with the authorized BRP Dealer's service manager or owner.

If the matter still remains unresolved, contact BRP by filling out the customer contact form at **[www.brp.com](http://www.brp.com)** or contact BRP by mail at one of the addresses listed under the *Contact Us* section of this guide.



## BRP INTERNATIONAL LIMITED WARRANTY: 2025 SKI-DOO® ELECTRIC SNOWMOBILES

### 1) SCOPE OF THE LIMITED WARRANTY

Bombardier Recreational Products Inc. (“**BRP**”) warrants its 2025 Ski-Doo electric snowmobiles (the “**Product**”) sold by distributors or dealers authorized by BRP to distribute the Product outside of the fifty United States, Canada, members of the European Economic Area (which is comprised of the member states of the European Union plus the United Kingdom, Norway, Iceland and Liechtenstein) (“**EEA**”), members states of the Commonwealth of the Independent States (including Ukraine and Turkmenistan) (“**CIS**”) and Turkey (a “**BRP Distributor/Dealer**”), from defects in material or workmanship for the period and under the conditions described below.

This limited warranty will become null and void if:

1. The Product was used for racing or any other competitive activity, at any point, even by a previous owner;
2. The Product has been altered or modified in such a way so as to adversely affect its operation, performance or durability, or has been altered or modified to change its intended use;
3. The Product has been altered or modified in such a way so as to adversely affect the high-voltage battery operation, performance or durability;
4. The Product’s high-voltage battery has been used as a stationary power source.

---

The on-board charger, inverter, and e-motor are covered under the vehicle's limited warranty period against defects in material or workmanship.

Non-factory installed parts and accessories are not covered under this limited warranty. Please refer to the applicable parts and accessories limited warranty text.

## 2) LIMITATIONS OF LIABILITY

**TO THE EXTENT PERMITTED BY LAW, THIS WARRANTY IS EXPRESSLY GIVEN AND ACCEPTED IN LIEU OF ANY AND ALL OTHER WARRANTIES, EXPRESSED OR IMPLIED, INCLUDING WITHOUT LIMITATION ANY WARRANTY OF MERCHANTABILITY OR FITNESS FOR A PARTICULAR PURPOSE. TO THE EXTENT THAT THEY CANNOT BE DISCLAIMED, THE IMPLIED WARRANTIES ARE LIMITED IN DURATION TO THE LIFE OF THE EXPRESS WARRANTY. INCIDENTAL AND CONSEQUENTIAL DAMAGES ARE EXCLUDED FROM COVERAGE UNDER THIS WARRANTY. SOME JURISDICTIONS DO NOT ALLOW FOR THE DISCLAIMERS, LIMITATIONS AND EXCLUSIONS IDENTIFIED ABOVE. AS A RESULT, THEY MAY NOT APPLY TO YOU. THIS WARRANTY GIVES YOU SPECIFIC RIGHTS, AND YOU MAY ALSO HAVE OTHER LEGAL RIGHTS WHICH MAY VARY FROM COUNTRY TO COUNTRY. BRP SHALL NOT BE HELD LIABLE IF PRODUCTS OR WARRANTY PARTS ARE NOT AVAILABLE IN YOUR COUNTRY FOR REASONS OUTSIDE OF BRP'S CONTROL.**

Neither the BRP Distributor/Dealer nor any other person has been authorized to make any affirmation, representation or warranty regarding the Product and/or its high-voltage battery, other than those contained in this limited warranty, and if made, shall not be enforceable against BRP.

BRP reserves the right to modify this limited warranty at any time, being understood that such modification will not alter the warranty conditions applicable to the products and/or its high-voltage batteries sold while this warranty is in effect.

---

### **3) EXCLUSIONS – ARE NOT WARRANTED**

This warranty does not cover damage or failures resulting from or caused by:

- Attempting to modify the on-board charger, inverter and/or e-motor, to gain faster charge times or increase the original power output will void the warranty.
- Opening the on-board charger enclosure.
- Opening the inverter enclosure.
- Improper towing or vehicle recovery from a depleted high voltage battery or other failure may damage the e-motor or other high voltage components. Failure to follow the recommended towing and/or recovery method prescribed in this manual will void the warranty.

The following are not warranted under any circumstances:

- Normal wear and tear;
- Routine maintenance items, tune ups, adjustments;
- Damage caused by failure to provide proper maintenance and/or storage, as described in the Operator's Guide;
- Damage resulting from removal of parts, improper repairs, service, maintenance, modifications or use of parts or accessories not manufactured or approved by BRP or resulting from repairs done by a person that is not an authorized servicing BRP Distributor/Dealer;
- Damage caused by abuse, abnormal use, neglect, use of the Product on surfaces other than snow, or operation of the product in a manner inconsistent with the recommended operation described in the Operator's Guide;
- Damage resulting from accident, submersion, fire, theft, vandalism or any act of God;
- Operation with chemicals, oils or lubricants which are not suitable for use with the product (see the Operator's Guide);
- Snow or water ingestion;
- Incidental or consequential damages, or damages of any kind including without limitation towing, storage, telephone, rental, taxi, inconvenience, insurance coverage, loan payments, loss of time, loss of income;

- 
- Damage resulting from studs installed on tracks if the installation does not conform to BRP's instructions;
  - Damage caused by failure to provide proper maintenance and/or storage, as described in the Operator's Guide. Ambient temperatures above 40 °C (104 °F) may damage the high-voltage battery and void the warranty;
  - Damage caused by exposing the high voltage battery to contact with a direct flame;
  - Physical damage to the high voltage battery or intentional attempt to reduce the life of the high voltage battery;
  - Damage to internal components resulting from dis-assembly, opening the high-voltage battery enclosure is strictly forbidden;
  - Damage resulting from incorrect charging procedures or incompatible charging devices;
  - Damage to vehicle's components resulting from a complete discharge of the high-voltage battery;
  - Consequential damage caused by the failure to repair an existing problem;
  - Damage resulting from failure to install a software update;
  - Loss of battery capacity due to or resulting from gradual capacity loss.<sup>(1)</sup>

<sup>(1)</sup>Any capacity/range reduction-based claim must be confirmed by and approved by BRP to be eligible for coverage.

## 4) WARRANTY COVERAGE PERIOD

The vehicle limited warranty will be in effect from (1) the date of delivery to the first retail consumer, or (2) the date the Product is first put into use, whichever occurs first and for the applicable period below:

- **TWELVE (12) consecutive months**, for private use or commercial use owners. However, the warranty coverage period on a snowmobile delivered between June 1<sup>st</sup> and December 1<sup>st</sup> of a given year will expire November 30<sup>th</sup> of the following year.

The repair or replacement of parts or the performance of service under this warranty does not extend the life of this limited warranty beyond its original expiration date.

### *HIGH-VOLTAGE BATTERY*

The high-voltage battery limited warranty will be in effect for TWENTY-FOUR (24) consecutive months, or eight thousand kilometers (8,000 km) / five thousand miles (5,000 mi), whichever occurs first, **only** if the high-voltage battery state of health (SOH) is equal or greater than ( $\geq$ ) seventy percent (70%) of initial capacity.

The repair or replacement of parts or the performance of service under this warranty does not extend the life of this warranty beyond its original expiration date. Loss of battery capacity resulting from gradual capacity loss is NOT covered under this warranty beyond the terms and limit specified above.

---

## 5) CONDITIONS REQUIRED FOR WARRANTY COVERAGE

This warranty coverage is available **only** if each of the following conditions has been fulfilled:

- The Product must be purchased as new and unused by its first owner from a BRP Distributor/Dealer authorized to distribute the Product in the country in which the sale occurred;
- The BRP specified pre-delivery inspection process must be completed and documented and signed by the purchaser;
- The Product must have undergone proper registration by an authorized BRP Distributor/Dealer;
- The Product must be purchased in the country in which the purchaser resides; and Routine maintenance outlined in the Operator's Guide must be timely performed in order to maintain warranty coverage. BRP reserves the right to make warranty coverage contingent upon proof of proper maintenance.

BRP will not honor this limited warranty to any use owner if one of the preceding conditions has not been met. Such limitations are necessary in order to allow BRP to preserve both the safety of its products, and also that of its consumers and the general public.



## 6) WHAT TO DO TO OBTAIN WARRANTY COVERAGE

The customer and/or commercial operator must cease using the Product upon the appearance of an anomaly, notify a servicing BRP Distributor/Dealer or BRP directly within three (3) days of the appearance of the anomaly and provide the BRP Distributor/Dealer with reasonable access to the Product and reasonable opportunity to repair it.

All parts replaced under this limited warranty become the property of BRP.

## 7) WHAT BRP WILL DO

BRP's obligations under this warranty are limited to, at its sole discretion, repairing parts found defective under normal use, maintenance and service, or replacing such parts without charge for parts and labor, at any authorized BRP Distributor/Dealer during the warranty coverage period under the conditions described herein. No claim of breach of warranty shall be cause for cancellation or rescission of the sale of the Product to the owner.

BRP reserves the right to improve or modify products from time to time without assuming any obligation to modify products previously manufactured.

## 8) TRANSFER

If the ownership of a product is transferred during the warranty coverage period, this limited warranty, subject to its terms and conditions, will NOT be transferred to the new owner.

---

## 9) CONSUMER ASSISTANCE

In the event of a controversy or a dispute in connection with this limited warranty, BRP suggests that you try to resolve the issue at the BRP Distributor/Dealer level. We recommend discussing the issue with the authorized BRP Distributor/Dealer's service manager or owner.

If the matter still remains unresolved, contact BRP by filling out the customer contact form at **www.brp.com** or contact BRP by mail at one of the addresses listed under the *Contact Us* section of this guide.

## **BRP LIMITED WARRANTY FOR THE EUROPEAN ECONOMIC AND THE COMMONWEALTH OF THE INDEPENDENT STATES (CIS) AREAS AND TURKEY: 2025 SKI-DOO® ELECTRIC SNOWMOBILES**

### **1) SCOPE OF THE LIMITED WARRANTY**

Bombardier Recreational Products Inc. ("**BRP**") warrants its 2025 Ski-Doo electric snowmobiles (the "**Product**") and its high-voltage batteries sold by distributors or dealers authorized by BRP to distribute the Product in member states of the European Economic Area (which is comprised of the states of the European Union plus the United Kingdom, Norway, Iceland and Liechtenstein) ("**EEA**"), member states of the Commonwealth of the Independent States (including Ukraine and Turkmenistan) ("**CIS**") and Turkey (a "**BRP Distributor/Dealer**") from defects in material or workmanship for the period and under the conditions described below.

---

This limited warranty will become null and void if:

1. The Product was used for racing or any other competitive activity, at any point, even by a previous owner;
2. The Product has been altered or modified in such a way so as to adversely affect its operation, performance or durability, or has been altered or modified to change its intended use;
3. The Product has been altered or modified in such a way so as to adversely affect the high-voltage battery operation, performance or durability;
4. The Product's high-voltage battery has been used as a stationary power source.

The on-board charger, inverter, and e-motor are covered under the vehicle's limited warranty period against defects in material or workmanship.

Non-factory installed parts and accessories are not covered under this limited warranty. Please refer to the applicable parts and accessories limited warranty text.

## 2) LIMITATIONS OF LIABILITY

**TO THE EXTENT PERMITTED BY LAW, THIS WARRANTY IS EXPRESSLY GIVEN AND ACCEPTED IN LIEU OF ANY AND ALL OTHER WARRANTIES, EXPRESSED OR IMPLIED, INCLUDING WITHOUT LIMITATION ANY WARRANTY OF MERCHANTABILITY OR FITNESS FOR A PARTICULAR PURPOSE. TO THE EXTENT THAT THEY CANNOT BE DISCLAIMED, THE IMPLIED WARRANTIES ARE LIMITED IN DURATION TO THE LIFE OF THE EXPRESS WARRANTY. INCIDENTAL AND CONSEQUENTIAL DAMAGES ARE EXCLUDED FROM COVERAGE UNDER THIS WARRANTY. SOME JURISDICTIONS DO NOT ALLOW FOR THE DISCLAIMERS, LIMITATIONS AND EXCLUSIONS IDENTIFIED ABOVE. AS A RESULT, THEY MAY NOT APPLY TO YOU. THIS WARRANTY GIVES YOU SPECIFIC RIGHTS, AND YOU MAY ALSO HAVE OTHER LEGAL RIGHTS WHICH MAY VARY FROM COUNTRY TO COUNTRY. BRP SHALL NOT BE HELD LIABLE IF PRODUCTS OR WARRANTY PARTS ARE NOT AVAILABLE IN YOUR COUNTRY FOR REASONS OUTSIDE OF BRP'S CONTROL.**

For Products purchased in France, refer to the France specific section below.

Neither the BRP Distributor/Dealer nor any other person has been authorized to make any affirmation, representation or warranty regarding the Product and/or its high-voltage battery, other than those contained in this limited warranty, and if made, shall not be enforceable against BRP.

BRP reserves the right to modify this limited warranty at any time, being understood that such modification will not alter the warranty conditions applicable to the products and/or its high-voltage batteries sold while this warranty is in effect.

---

### **3) EXCLUSIONS – ARE NOT WARRANTED**

This warranty does not cover damage or failures resulting from or caused by:

- Attempting to modify the on-board charger, inverter and/or e-motor, to gain faster charge times or increase the original power output will void the warranty.
- Opening the on-board charger enclosure.
- Opening the inverter enclosure.
- Improper towing or vehicle recovery from a depleted high voltage battery or other failure may damage the e-motor or other high voltage components. Failure to follow the recommended towing and/or recovery method prescribed in this manual will void the warranty.

The following are not warranted under any circumstances:

- Normal wear and tear;
- Routine maintenance items, tune ups, adjustments;
- Damage caused by failure to provide proper maintenance and/or storage, as described in the Operator's Guide;
- Damage resulting from removal of parts, improper repairs, service, maintenance, modifications or use of parts or accessories not manufactured or approved by BRP or resulting from repairs done by a person that is not an authorized servicing BRP Distributor/Dealer;
- Damage caused by abuse, abnormal use, neglect, use of the Product on surfaces other than snow, or operation of the product in a manner inconsistent with the recommended operation described in the Operator's Guide;
- Damage resulting from accident, submersion, fire, theft, vandalism or any act of God;
- Operation with chemicals, oils or lubricants which are not suitable for use with the product (see the Operator's Guide);
- Snow or water ingestion;
- Incidental or consequential damages, or damages of any kind including without limitation towing, storage, telephone, rental, taxi, inconvenience, insurance coverage, loan payments, loss of time, loss of income;

- 
- Damage resulting from studs installed on tracks if the installation does not conform to BRP's instructions;
  - Damage caused by failure to provide proper maintenance and/or storage, as described in the Operator's Guide. Ambient temperatures above 40 °C (104 °F) may damage the high-voltage battery and void the warranty;
  - Damage caused by exposing the high voltage battery to contact with a direct flame;
  - Physical damage to the high voltage battery or intentional attempt to reduce the life of the high voltage battery;
  - Damage to internal components resulting from dis-assembly, opening the high-voltage battery enclosure is strictly forbidden;
  - Damage resulting from incorrect charging procedures or incompatible charging devices;
  - Damage to vehicle's components resulting from a complete discharge of the high-voltage battery;
  - Consequential damage caused by the failure to repair an existing problem;
  - Damage resulting from failure to install a software update;
  - Loss of battery capacity due to or resulting from gradual capacity loss.<sup>(1)</sup>

<sup>(1)</sup>Any capacity/range reduction-based claim must be confirmed by and approved by BRP to be eligible for coverage.



## 4) WARRANTY COVERAGE PERIOD

The vehicle limited warranty will be in effect from (1) the date of delivery to the first retail consumer, or (2) the date the Product is first put into use, whichever occurs first and for the applicable period below:

- **TWENTY-FOUR (24) consecutive months**, for private use or commercial use owners. However, the warranty coverage period on a snowmobile delivered between June 1st and December 1st of a given year will expire November 30th of the following year.

### *HIGH-VOLTAGE BATTERY*

The high-voltage battery limited warranty will be in effect for TWENTY-FOUR (24) consecutive months, or eight thousand kilometers (8,000 km) / five thousand miles (5,000 mi), whichever occurs first, **only** if the high-voltage battery state of health (SOH) is equal or greater than ( $\geq$ ) seventy percent (70%) of initial capacity.

The repair or replacement of parts or the performance of service under this warranty does not extend the life of this warranty beyond its original expiration date. Loss of battery capacity resulting from gradual capacity loss is NOT covered under this warranty beyond the terms and limit specified above.

---

## 5) FOR PRODUCTS SOLD IN FRANCE ONLY

The seller shall deliver goods that are complying with the contract and shall be responsible for defects existing upon delivery. The seller shall also be responsible for defects resulting from packaging, assembling instructions or the installation when it is its responsibility per the contract or if accomplished under its responsibility. To be compliant with the contract, the good shall:

1. Be fit for normal use for goods similar thereto and, if applicable:
  - Correspond to the description provided by the seller and have the qualities presented to the buyer through sample or model;
  - Have the qualities that a buyer may legitimately expect considering the public declarations of the seller, the manufacturer of its representative, including in advertising or labeling; or
2. Have the characteristics mutually agreed upon as between the parties or be fit for the specific use intended by the buyer and brought to the attention of the seller and which were accepted by the seller.

The action for failure to comply is prescribed after two years after delivery of the goods. The seller is responsible for the warranty for hidden defects of the good sold if such hidden defects are rendering the good unfit for the intended use, or if they diminish its use in such a way that the buyer would not have acquired the good or would have given a lesser price, had he known. The action for such hidden defects shall be taken by the buyer within 2 years of the discovery of the defect.

## 6) CONDITIONS REQUIRED FOR WARRANTY COVERAGE

This warranty coverage is available **only** if each of the following conditions has been fulfilled:

- The Product must be purchased as new and unused by its first owner from a BRP Distributor/Dealer authorized to distribute the Product in the country, or in the case of the EEA union of countries, in which the sale occurred ;
- The BRP specified pre-delivery inspection process must be completed and documented by the purchaser and the authorized BRP Distributor/Dealer and signed by the purchaser;
- The Product must have undergone proper registration by an authorized snowmobile BRP Distributor/ Dealer;
- The Product must be purchased in the country in which the purchaser resides; and
- Routine maintenance outlined in the Operator's Guide must be timely performed in order to maintain warranty coverage. BRP reserves the right to make warranty coverage contingent upon proof of proper maintenance.

BRP will not honor this limited warranty to any use owner if one of the preceding conditions has not been met. Such limitations are necessary in order to allow BRP to preserve both the safety of its products, and also that of its consumers and the general public.

---

## **7) WHAT TO DO TO OBTAIN WARRANTY COVERAGE**

The customer and/or commercial operator must cease using the Product upon the appearance of an anomaly, notify a servicing BRP Distributor/Dealer or BRP directly within three (3) days of the appearance of the anomaly and provide the Dealer with reasonable access to the Product and reasonable opportunity to repair it.

All parts replaced under this limited warranty become the property of BRP.

## **8) WHAT BRP WILL DO**

BRP's obligations under this warranty are limited to, at its sole discretion, repairing parts found defective under normal use, maintenance and service, or replacing such parts without charge for parts and labor, at any authorized BRP dealer during the warranty coverage period under the conditions described herein. No claim of breach of warranty shall be cause for cancellation or rescission of the sale of the Product to the owner.

BRP reserves the right to improve or modify products from time to time without assuming any obligation to modify products previously manufactured.

## **9) TRANSFER**

If the ownership of a product is transferred during the warranty coverage period, this limited warranty, subject to its terms and conditions, will NOT be transferred to the new owner.

## 10) CONSUMER ASSISTANCE

In the event of a controversy or a dispute in connection with this limited warranty, BRP suggests that you try to resolve the issue at the BRP Distributor/Dealer level. We recommend discussing the issue with the authorized BRP Distributor/Dealer's service manager or owner.

If the matter still remains unresolved, contact BRP by filling out the customer contact form at [www.brp.com](http://www.brp.com) or contact BRP by mail at one of the addresses listed under the *Contact Us* section of this guide.



## **10** CUSTOMER INFORMATION - TABLE OF CONTENTS

---

<b>DATA PRIVACY INFORMATION</b> .....	<b>10-2</b>
<b>CONTACT US</b> .....	<b>10-7</b>
Europe, Middle East and Africa .....	10-7
North America .....	10-8
<b>CHANGE OF ADDRESS/ OWNERSHIP</b> .....	<b>10-9</b>

---

## DATA PRIVACY INFORMATION

Bombardier Recreational Products Inc., its affiliates and subsidiaries (“BRP”) are committed to protecting your privacy and support a general policy of openness about how we collect, use and disclose your personal information in the course of managing our relationship with you. **More details can be found by visiting BRP’s Privacy Policy at:**

**<https://brp.com/en/privacy-policy.html> or by scanning the QR Code below.**

Please be assured that we have appropriate security measures in place to ensure that your personal information is protected against loss and unauthorized access.



Your personal information that may be collected by BRP, directly from you or from authorized dealers or authorized third parties, includes:

- **Contact, Demographic & Registration Information** (e.g., name, full address, phone number, email, gender, ownership history, language of communication)
- **Vehicle Information** (e.g., serial number, purchase and delivery date, unit usage, vehicle location and movements)
- **Third Party Information** (e.g., information received from BRP partners, joint-marketing activities information, social media)
- **Technological Information** (e.g., IP address, type of device, operating system, browser type, webpages you view, cookies and similar technologies when you use BRP or dealers' websites or mobile application)
- **Interaction with BRP Information** (e.g., information collected when you call BRP's in-house sales representatives, buy items on a BRP website, sign up for BRP emails, participate in BRP-sponsored contests and sweepstakes or attend BRP-sponsored events)
- **Transactional Information** (e.g., information necessary to handle returns, payment information when you purchase our products or services through our websites or mobile applications and other issues related to your purchase of BRP products)

---

This information may be used and processed for the following purposes:

- Safety & Security
- Customer Support for Sales & After Sales (e.g., complete or follow up with you about your purchase or maintenance)
- Registration & Warranty
- Communication (e.g., sending you a BRP satisfaction survey)
- Online Behavioural Advertising, Profiling and Location-Based Services (e.g., offer customized experience)
- Compliance & Dispute Resolution
- Marketing & Advertising
- Assistance (e.g., help with any delivery issues, handle returns, and other issues related to your purchase of BRP products).

We also may use personal information to generate aggregated or statistical data that no longer identifies you personally.

**Your personal information may be disclosed to the following: BRP, BRP's authorized dealerships, distributors, service providers, advertising & market research partners and other authorized third parties.**

We may receive information about you from diverse sources, including third parties, such as BRP's authorized dealerships and partners, with whom we offer services or engage in joint-marketing activities. We may also receive information about you from social media platforms such as Facebook and Twitter when you interact with us on those platforms.

Depending on the circumstances, your personal information may be communicated outside the region where you reside. Your personal information is retained only for as long as necessary for the purpose for which we obtained it and according to our retention policies.

To exercise your data privacy rights (e.g. right of access, right of rectification), to withdraw your consent in order to be removed from the address list for marketing purposes or for the satisfaction survey or for general data privacy questions, please contact BRP's Data Protection Officer at **privacyofficer@brp.com** or by mail at:

BRP Legal Service, 726 St-Joseph, Valcourt, Quebec, Canada, J0E 2L0.

---

**When BRP processes your personal information, they do so in compliance with its Privacy Policy available at: <https://www.brp.com/en/privacy-policy.html> or by using the following QR Code.**



### CONTACT US

[www.brp.com](http://www.brp.com)

#### **Europe, Middle East and Africa**

##### **Belgium**

Oktrooiplein 1  
9000 Gent

##### **Czech Republic**

Stefanikova 43a  
Prague 5  
150 00

##### **Germany**

Alte Papierfabrik 16  
D-40699 Erkrath

##### **Finland**

Isoaavantie 7  
PL 8040  
96101 Rovaniemi

##### **France**

Arteparc Bâtiment B  
Route de la côte d'Azur,  
13 590 Meyreuil

##### **Norway**

Ingvald Ystgaardsvei 15  
N-7484 Trondheim  
Salg, marketing, ettermarked

---

**Sweden**

Spinnvägen 15  
903 61 Umeå  
Sweden 90821

**Switzerland**

Avenue d'Ouchy 4-6  
1006 Lausanne

**North America****Canada**

3200A, rue King Ouest,  
Suite 300  
Sherbrooke (Québec) J1L 1C9

**United States of America**

10101 Science Drive  
Sturtevant, Wisconsin  
53177

### CHANGE OF ADDRESS/OWNERSHIP

If your address has changed or if you are the new owner of the snowmobile, be sure to notify BRP by either:

- Notifying an authorized BRP snowmobile dealer or distributor.
- **North America only:** calling 1-888-272-9222.
- Mailing one of the change of address cards on the following pages to one of the BRP addresses indicated in the *Contact Us* section of this guide.

In case of change of ownership, please include a proof that the former owner agreed to the transfer.

Notifying BRP, even after the expiration of the limited warranty, is very important as it enables BRP to reach the snowmobile owner if necessary, like when safety recalls are initiated. It is the owner's responsibility to notify BRP.

**STOLEN UNITS:** If your personal snowmobile is stolen, you should notify BRP or an authorized BRP snowmobile dealer. We will ask you to provide your name, address, phone number, the vehicle identification number and the date it was stolen.

---

This page is  
intentionally blank



# CUSTOMER INFORMATION

CHANGE OF ADDRESS  CHANGE OF OWNERSHIP  

VEHICLE IDENTIFICATION NUMBER

Model Number	Vehicle Identification Number (V.I.N.)
--------------	--

OLD ADDRESS OR PREVIOUS OWNER:

NAME

NO. STREET APT

CITY STATE/PROVINCE ZIP/POSTAL CODE

COUNTRY TELEPHONE

NEW ADDRESS OR NEW OWNER:

NAME

NO. STREET APT

CITY STATE/PROVINCE ZIP/POSTAL CODE

COUNTRY TELEPHONE

E-MAIL ADDRESS

CHANGE OF ADDRESS  CHANGE OF OWNERSHIP  

VEHICLE IDENTIFICATION NUMBER

Model Number	Vehicle Identification Number (V.I.N.)
--------------	--

OLD ADDRESS OR PREVIOUS OWNER:

NAME

NO. STREET APT

CITY STATE/PROVINCE ZIP/POSTAL CODE

COUNTRY TELEPHONE

NEW ADDRESS OR NEW OWNER:

NAME

NO. STREET APT

CITY STATE/PROVINCE ZIP/POSTAL CODE

COUNTRY TELEPHONE

E-MAIL ADDRESS

---

This page is  
intentionally blank

# CUSTOMER INFORMATION

CHANGE OF ADDRESS  CHANGE OF OWNERSHIP  

VEHICLE IDENTIFICATION NUMBER

Model Number	Vehicle Identification Number (V.I.N.)
--------------	--

OLD ADDRESS OR PREVIOUS OWNER:

NAME

NO. STREET APT

CITY STATE/PROVINCE ZIP/POSTAL CODE

COUNTRY TELEPHONE

NEW ADDRESS OR NEW OWNER:

NAME

NO. STREET APT

CITY STATE/PROVINCE ZIP/POSTAL CODE

COUNTRY TELEPHONE

E-MAIL ADDRESS

CHANGE OF ADDRESS  CHANGE OF OWNERSHIP  

VEHICLE IDENTIFICATION NUMBER

Model Number	Vehicle Identification Number (V.I.N.)
--------------	--

OLD ADDRESS OR PREVIOUS OWNER:

NAME

NO. STREET APT

CITY STATE/PROVINCE ZIP/POSTAL CODE

COUNTRY TELEPHONE

NEW ADDRESS OR NEW OWNER:

NAME

NO. STREET APT

CITY STATE/PROVINCE ZIP/POSTAL CODE

COUNTRY TELEPHONE

E-MAIL ADDRESS

---

This page is  
intentionally blank

# CUSTOMER INFORMATION

CHANGE OF ADDRESS  CHANGE OF OWNERSHIP  

VEHICLE IDENTIFICATION NUMBER

Model Number	Vehicle Identification Number (V.I.N.)
--------------	--

OLD ADDRESS OR PREVIOUS OWNER:

NAME

NO. STREET APT

CITY STATE/PROVINCE ZIP/POSTAL CODE

COUNTRY TELEPHONE

NEW ADDRESS OR NEW OWNER:

NAME

NO. STREET APT

CITY STATE/PROVINCE ZIP/POSTAL CODE

COUNTRY TELEPHONE

E-MAIL ADDRESS

CHANGE OF ADDRESS  CHANGE OF OWNERSHIP  

VEHICLE IDENTIFICATION NUMBER

Model Number	Vehicle Identification Number (V.I.N.)
--------------	--

OLD ADDRESS OR PREVIOUS OWNER:

NAME

NO. STREET APT

CITY STATE/PROVINCE ZIP/POSTAL CODE

COUNTRY TELEPHONE

NEW ADDRESS OR NEW OWNER:

NAME

NO. STREET APT

CITY STATE/PROVINCE ZIP/POSTAL CODE

COUNTRY TELEPHONE

E-MAIL ADDRESS

---

This page is  
intentionally blank

















---

## NOTES

---

---

---

---

---

---

---

---

---

---

---

---



---

Model No. \_\_\_\_\_

**VEHICLE**  
IDENTIFICATION NUMBER (V.I.N.) \_\_\_\_\_

**HIGH-VOLTAGE BATTERY**  
SERIAL NUMBER \_\_\_\_\_

**Owner:** \_\_\_\_\_  
NAME

\_\_\_\_\_  
No. STREET APT

\_\_\_\_\_  
CITY STATE/PROVINCE ZIP/POSTAL CODE

**Purchase Date** \_\_\_\_\_  
YEAR MONTH DAY

**Warranty Expiry Date** \_\_\_\_\_  
YEAR MONTH DAY

To be completed by the dealer at the time of the sale.

DEALER IMPRINT AREA



In Canada, products are distributed and serviced by Bombardier Recreational Products Inc. (BRP).

In the USA, products are distributed and serviced by BRP US Inc.

In the European Economic Area (which is comprised of the member states of the European Union plus the United Kingdom, Norway, Iceland and Liechtenstein), the Commonwealth of the Independent States (including Ukraine and Turkmenistan) and Turkey, products are distributed and serviced by BRP European Distribution S.A. and other affiliates or subsidiaries of BRP.

For all other countries, products are distributed and serviced by Bombardier Recreational Products Inc. (BRP) or its affiliates.

<sup>TM</sup>® Trademarks of BRP or its affiliates.

This is a non-exhaustive list of trademarks that are the property of Bombardier Recreational Products Inc. or its affiliates.

Trademarks may not be registered in every jurisdictions.

BRP GO®

D.E.S.S.<sup>TM</sup>

HPG<sup>TM</sup>

iTC<sup>TM</sup>

LinQ®

ROTAX E-POWER<sup>TM</sup>

SKI-DOO®

XPS®

All rights reserved. No parts of this Manual may be reproduced in any form without the prior written permission of Bombardier Recreational Products Inc.

©2024 BOMBARDIER RECREATIONAL PRODUCTS INC.

*[www.brp.com](http://www.brp.com)*

---

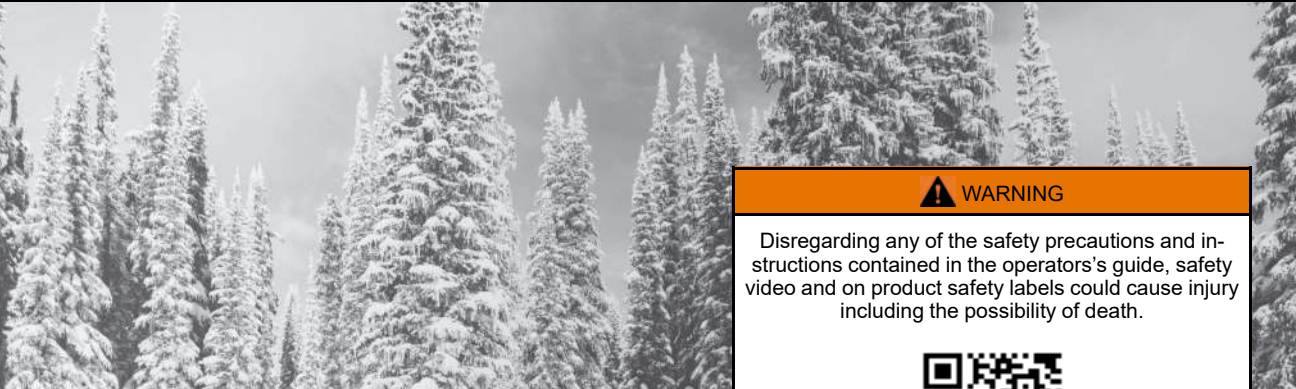

## WARNING

Disregarding any of the safety precautions and instructions contained in the operators's guide, safety video and on product safety labels could cause injury including the possibility of death.



520003302

*ski-doo* *LYNX* *SEA-DOO* *CAN-AM* *ROTAX* *ALUMACraft* *MANITOU* *QUINTREX*

 WARNING

Disregarding any of the safety precautions and instructions contained in the operator's guide, safety video and on product safety labels could cause injury including the possibility of death.

