

LYNX[®]

RAVE RS[™] Series

Operator's Guide 2020

Includes
Safety, Vehicle
and Maintenance Information



⚠ WARNING

Read this guide thoroughly.
It contains important safety information.
Minimum recommended operator's age: 16 years old.
Keep this Operator's guide for reference.

6 1 9 9 0 0 9 7 3

Original Instructions

WARNING

Disregarding any of the safety precautions and instructions contained in this Operator's Guide, *SAFETY VIDEO* and on-product safety labels could cause injury including the possibility of death!

WARNING

This vehicle may exceed the performance of other vehicles you may have ridden. Take time to familiarize yourself with your new vehicle.

OPERATOR'S GUIDE 2020

RACING

Rave 600RS E-TEC



Lynx products are manufactured by Bombardier Recreational Products Inc.

The following are trademarks of Bombardier Recreational Products Inc. or its subsidiaries.

ROTAX™ HPG™ RAVE™

E-TEC® Lynx® XPS™

The KYB Pro series is a registered mark of KYB America LLC.

FOREWORD

Deutsch	Dieses Handbuch ist möglicherweise in Ihrer Landessprache verfügbar. Bitte wenden Sie sich an Ihren Händler oder besuchen Sie: www.operatorsguides.brp.com
English	This guide may be available in your language. Check with your dealer or go to: www.operatorsguides.brp.com
Español	Es posible que este manual esté disponible en su idioma. Consulte a su distribuidor o visite: www.operatorsguides.brp.com
Français	Ce guide peut être disponible dans votre langue. Vérifier avec votre concessionnaire ou aller à: www.operatorsguides.brp.com
Italiano	Questa guida potrebbe essere disponibile nella propria lingua. Contattare il concessionario o consultare: www.operatorsguides.brp.com
中文	本手册可能有您的语种的翻译版本。请向经销商询问，或者登录 www.operatorsguides.brp.com 查询。
日本語	このガイドは、言語によって翻訳版が用意されています。ディーラーに問い合わせるか、次のアドレスでご確認ください： www.operatorsguides.brp.com
Nederlands	Deze handleiding kan beschikbaar zijn in uw taal. Vraag het aan uw dealer of ga naar: www.operatorsguides.brp.com
Norsk	Denne boken kan finnes tilgjengelig på ditt eget språk. Kontakt din forhandler eller gå til: www.operatorsguides.brp.com
Português	Este manual pode estar disponível em seu idioma. Fale com sua concessionária ou visite o site: www.operatorsguides.brp.com
Русский	Воспользуйтесь руководством на вашем языке. Узнайте о его наличии у дилера или на странице по адресу www.operatorsguides.brp.com
Suomi	Käyttöohjekirja voi olla saatavissa omalla kielelläsi. Tarkista jälleenmyyjältä tai käy osoitteessa: www.operatorsguides.brp.com
Svenska	Denna bok kan finnas tillgänglig på ditt språk. Kontakta din återförsäljare eller gå till: www.operatorsguides.brp.com

Congratulations on your purchase of a new Lynx® snowmobile. Whatever model you have chosen, it is backed by the Bombardier Recreational Products Inc. (BRP) warranty and a network of authorized Lynx snowmobile dealers ready to provide the parts, service or accessories you may require.

Your dealer is committed to your satisfaction. He has taken training to perform the initial set-up and inspection of your snowmobile as well as completed the final adjustment required to suit your specific weight and riding environment before you took possession.

At delivery, you were informed of the warranty coverage and signed the *PREDELIVERY CHECK LIST* to ensure your new vehicle was prepared to your entire satisfaction.

Know Before you Go

To learn how to reduce the risk for you or bystanders being injured or killed, read the following sections before you operate the vehicle:

- SAFETY INFORMATION
- VEHICLE INFORMATION.

Also read all safety labels on your snowmobile and watch attentively your SAFETY VIDEO located at www.brplynx.com/en/owners/safety/safety-information.html.



We highly recommend that you take a safety riding course. Please check with your dealer or local authorities for availability in your area.

Failure to follow the warnings contained in this Operator's Guide can result in SERIOUS INJURY or DEATH.

The proper functioning of a snowmobile depends in part on the surface on which it is driven.

Driving on very hard or snow-free surfaces compromises the cooling of the engine and the lubrication of rear suspension components. Avoid prolonged driving on such surfaces.

Safety Messages

The types of safety messages, what they look like and how they are used in this guide are explained as follows:

The safety alert symbol  indicates a potential injury hazard.

WARNING

Indicates a potential hazard, if not avoided, could result in serious injury or death.

 CAUTION Indicates a hazard situation which, if not avoided, could result in minor or moderate injury.

NOTICE Indicates an instruction which, if not followed, could severely damage vehicle components or other property.

About this Operator's Guide

This Operator's Guide has been prepared to acquaint the owner/operator with this snowmobile and its various controls, safe riding and maintenance instructions.

The following terminology in regards to operator and vehicle configuration is used as follows throughout this guide:

- **Operator:** refers to the person being behind the controls and driving the snowmobile.
- **1-UP:** refers to a model designed for an operator only.

Keep this Operator's Guide so you can refer to it for things such as maintenance, troubleshooting and instructing others.

Note that this guide is available in several languages. In the event of any discrepancy, the English version shall prevail.

If you want to view and/or print an extra copy of your Operator's Guide, simply visit the following website www.operatorsguides.brp.com.

The information contained in this document is correct at the time of publication. BRP, however, maintains a policy of continuous improvement of its products without imposing upon itself any obligation to install them on products previously manufactured. Due to late changes, some differences between the manufactured product and the descriptions and/or specifications in this guide may occur. BRP reserves the right at any time to discontinue or change specifications, designs, features, models or equipment without incurring any obligation upon itself.

This Operator's Guide should remain with the vehicle when it's sold.

TABLE OF CONTENTS

FOREWORD	1
Know Before you Go	2
Safety Messages.....	2
About this Operator's Guide	3

SAFETY INFORMATION

GENERAL PRECAUTIONS	10
Avoid Carbon Monoxide Poisoning	10
Avoid Gasoline Fires and Other Hazards.....	10
Avoid Burns from Hot Parts	11
Accessories and Modifications	11
SPECIAL SAFETY MESSAGES	12
RIDING THE VEHICLE	17
Pre-Ride Inspection	17
How to Ride	20
TRACTION ENHANCING PRODUCTS	24
Manoeuvrability	24
Acceleration	27
Braking.....	27
Important Safety Rules.....	27
Effects of Having a Studded Track on the Life of the Snowmobile	28
Installation of Studs on BRP Approved Tracks.....	28
Maintenance/Replacement	31
IMPORTANT ON-PRODUCT LABELS	32
Hang Tag(s)	32
Vehicle Safety Labels	34

VEHICLE INFORMATION

CONTROLS, INSTRUMENTS AND EQUIPMENT	44
1) Handlebar	45
2) Throttle Lever.....	45
3) Brake Lever	46
4) Parking Brake Lever	46
5) Engine Cut-off Switch	48
6) Multifunction Digital Gauge	49
7) Exhaust Tuned Pipe Preheat Button	60
8) Heated Grips and Throttle Lever Switch	60

CONTROLS, INSTRUMENTS AND EQUIPMENT (cont'd)	
9) Rewind Starter Handle	61
10) Drive Belt Guard.....	62
11) Front and Rear Bumpers	65
12) Side Panels	67
13) Footrests	69
FUEL AND OIL.....	72
Fuel Requirements	72
Recommended Oil	73
Vehicle Fueling Procedure	74
BREAK-IN PERIOD	76
Operation During Break-In	76
BASIC PROCEDURES.....	78
Engine Starting Procedure	78
Vehicle Warm-Up.....	78
Shutting Off the Engine	79
RIDING CONDITIONS AND YOUR SNOWMOBILE	80
Temperature	80
Hard Packed Snow	80
SPECIAL OPERATION	81
Towing Another Snowmobile	81
TUNE YOUR RIDE.....	82
Rear Suspension Adjustments.....	83
Front Suspension Adjustments	89
Adjustment Tips According to Vehicle Behavior.....	93
VEHICLE TRANSPORTATION	96

MAINTENANCE

MAINTENANCE SCHEDULE	98
MAINTENANCE PROCEDURES	100
Engine Coolant	100
Exhaust System	102
Spark Plugs Replacement.....	103
Brake Fluid.....	107
Chaincase Oil.....	109
Drive Chain	112
Drive Belt	113

MAINTENANCE PROCEDURES (cont'd)

Drive Pulley	117
Track	121
Suspension	129
Skis	131
Fuses	131

VEHICLE CARE 133

Post-Operation Care.....	133
Vehicle Cleaning and Protection	133

STORAGE..... 134

TECHNICAL INFORMATION

VEHICLE IDENTIFICATION 136

Vehicle Description Decal	136
Identification Numbers	137

EC DECLARATION OF CONFORMITY 139

EAC DECLARATION OF CONFORMITY 140

SPECIFICATIONS (ENGINE)..... 141

SPECIFICATIONS (VEHICLE)..... 143

TROUBLE-SHOOTING

TROUBLESHOOTING GUIDELINES 148

MONITORING SYSTEM 150

Icons, Messages and Beeper Codes	150
Fault Codes.....	153

WARRANTY

BRP FINLAND OY INTERNATIONAL LIMITED WARRANTY: 2020 LYNX® SNOWMOBILES 156

BRP FINLAND OY LIMITED WARRANTY FOR THE EUROPEAN AND THE COMMONWEALTH OF THE INDEPENDENT STATES (CIS) AREAS AND TURKEY : 2020 LYNX® SNOWMOBILES 161

MAINTENANCE RECORDS 167

CUSTOMER INFORMATION

CONTACT US	174
Asia	174
Europe	174
North America	175
Oceania	175
South America	175
CHANGE OF ADDRESS/OWNERSHIP	176

SAFETY INFORMATION

GENERAL PRECAUTIONS

Avoid Carbon Monoxide Poisoning

All engine exhaust contains carbon monoxide, a deadly gas. Breathing carbon monoxide can cause headaches, dizziness, drowsiness, nausea, confusion and eventually death.

Carbon monoxide is a colorless, odorless, tasteless gas that may be present even if you do not see or smell any engine exhaust. Deadly levels of carbon monoxide can collect rapidly, and you can quickly be overcome and unable to save yourself. Also, deadly levels of carbon monoxide can linger for hours or days in enclosed or poorly ventilated areas. If you experience any symptoms of carbon monoxide poisoning, leave the area immediately, get fresh air and seek medical treatment.

To prevent serious injury or death from carbon monoxide:

- Never run the vehicle in poorly ventilated or partially enclosed areas such as garages, carports or barns. Even if you try to ventilate engine exhaust with fans or open windows and doors, carbon monoxide can rapidly reach dangerous levels.
- Never run the vehicle outdoors where engine exhaust can be drawn into a building through openings such as windows and doors.

Avoid Gasoline Fires and Other Hazards

Gasoline is extremely flammable and highly explosive. Fuel vapors can spread and be ignited by a spark or flame many feet away from the engine. To reduce the risk of fire or explosion, follow these instructions:

- Use only an approved gasoline container to store fuel.
- Strictly adhere to instructions in *VEHICLE FUELING PROCEDURE*.
- Never start or operate the engine if the fuel cap is not properly installed.

Gasoline is poisonous and can cause injury or death.

- Never siphon gasoline by mouth.
- If you swallow gasoline, get any in your eye or inhale gasoline vapor, see your doctor immediately.

If gasoline spills on you, wash with soap and water and change your clothes.

Avoid Burns from Hot Parts

The exhaust system and engine become hot during operation. Avoid contact during and shortly after operation to avoid burns.

Accessories and Modifications

Do not make unauthorized modifications, or use attachments or accessories that are not approved by BRP. Since these changes have not been tested by BRP, they may increase the risk of crashes or injuries, and they can make the vehicle illegal.

Tunnel accessories must be loaded onto vehicle as per instructions provided for each accessories.

See your authorized Lynx dealer for available accessories for your vehicle.

SPECIAL SAFETY MESSAGES

SEVERE INJURY OR DEATH can result if you do not follow these instructions:

- Always make a pre-ride inspection BEFORE you start the engine.
- Throttle mechanism should be checked for free movement and return to idle position before starting engine.
- Always attach tether cord eyelet to clothing before starting the engine.
- Never operate the engine without belt guard and brake disk guard securely installed or, with hood or side panels opened or removed. Never run the engine without drive belt installed. Running an unloaded engine such as without drive belt or with track raised, can be dangerous.
- Always engage parking brake before starting the engine.
- Everyone is a beginner the first time he sits behind the controls of a snowmobile regardless of previous experience in driving any other type of vehicle. The safe use of your snowmobile depends on many conditions such as visibility, speed, weather, environment, traffic, vehicle condition and the condition of the operator.
- Basic training is required for the safe operation of any snowmobile. Study your operator's guide paying particular attention to cautions and warnings. Join your local snowmobile club: its social activities and trail systems are planned for both fun and safety. Obtain basic instructions from your snowmobile dealer, friend, fellow club member or enroll in your state or provincial safety training program.
- Any new operator must read and understand all safety labels on the snowmobile, the Operator's Guide and watch the *SAFETY VIDEO* located at www.brplynx.com/en/owners/safety/safety-information.html before operating the snowmobile. Only allow a new operator to operate the snowmobile in a restricted flat area, at least until he is completely familiar with its operation. If snowmobile operator's training course is offered in your area, have him enroll.
- The performance of some snowmobiles may significantly exceed that of other snowmobiles you have operated. Therefore, use by novice or inexperienced operators is not recommended.
- Snowmobiles are used in many areas and in many snow conditions. Not all models perform the same in similar conditions. Always consult your snowmobile dealer when selecting the snowmobile model for your particular needs and uses.

- Injury or death may result to the snowmobile operator or bystander if the snowmobile is used in risky conditions which are beyond the operator's or snowmobile's capabilities or intended use.
- BRP recommends the operator has at least 16 years old of age. Verify also your local laws for age and training requirements.
- It is very important to inform any operator, regardless of his experience, of the handling characteristics of this snowmobile. The snowmobile configuration, such as ski stance, ski type, suspension type, track length, width and type vary from a model to another. The snowmobile handling is greatly influenced by these characteristics.
- The novice operator should become familiar with the snowmobile through practice on a level area at slow speeds before venturing far afield.
- Know your local laws. Federal, state, provincial and local government agencies have enacted laws and regulations pertaining to the safe use and operation of snowmobiles. It is your responsibility as a snowmobiler to learn and obey these laws and regulations. Respect and observance will result in safer snowmobiling for all. Be aware of the liability property damages and insurance laws regarding your equipment.
- Speeding can be fatal. In many cases, you cannot react or respond quickly enough to the unexpected. Always ride at a speed which is suitable to the trail, weather conditions and your own ability. Know your local rules. Speed limit may be in effect and meant to be observed.
- Always keep right hand side of the trail.
- Always keep a safe distance from other snowmobiles and bystanders.
- Remember, promotional material may show risky maneuvers performed by professional riders under ideal and/or controlled conditions. You should never attempt any such risky maneuvers if they are beyond your level of riding ability.
- Never use this vehicle with drugs or alcohol. They slow reaction time and impair judgement.
- Your snowmobile is not designed to be operated on public streets, roads or highways.

- Avoid road traveling. If you must do so, and it is permitted, reduce speed. The snowmobile is not designed to operate or turn on paving. When crossing a road, make a full stop, then look carefully in both directions before crossing at a 90° angle. Be wary of parked vehicles.
- Snowmobiling at night can be a delightful experience but because of reduced visibility, be extra cautious. Avoid unfamiliar terrain and be sure your lights are working. Always carry a flashlight and spare light bulbs.
- Never remove any original equipment from your snowmobile. Each vehicle has many built in safety features. Such features include various guards and consoles, plus reflective materials and safety labels.
- Nature is wonderful but don't let it distract your attention from driving. If you want to truly appreciate winter's scenery, stop your snowmobile on the side of the trail so that you don't become a hazard to others.
- Fences represent a very serious threat for both you and your snowmobile. Give a wide berth to telephone poles or posts.
- Hidden wires unseen from a distance can cause serious accidents.
- Always wear an approved safety helmet, eye protection and a face shield.
- Be aware of inherent risks associated with riding off trails, such as avalanche and other natural or man made hazards or obstacles.
- Tailgating another snowmobile should be avoided. If the snowmobile in front of you slows for any reason, its operator and passenger could be harmed through your neglect. Maintain a safe stopping distance between you and the snowmobile in front of you. Depending on the terrain condition, stopping may require a little more space than you think. Play it safe. Be prepared to use evasive driving.
- Venturing out alone with your snowmobile could also be hazardous. You could run out of fuel, have an accident, or damage your snowmobile. Remember, your snowmobile is capable of traveling further in half an hour than you may be able to walk in a day. Use the "buddy system". Always ride with a friend or member of your snowmobile club. Even then, tell someone where you are going and the approximate time you plan to return.

- Meadows sometimes have low areas where water accumulate and freezes over in winter. This ice is usually glare ice. Attempting to turn or brake on this surface could cause your vehicle to spin out of control. Never brake or attempt speeding or turning on glare ice. If you do happen to travel over such a condition, reduce speed by carefully releasing the throttle.
- Never "jump" with your snowmobile unless you're an experienced driver and the stunt is done in controlled / racing condition.
- While on safari, do not "gun" the throttle. Snow and ice can be thrown back into the path of a following snowmobile. In addition, when "gunning" the throttle, the vehicle digs into and leaves an irregular snow surface for others.
- Safaris are both fun and enjoyable but don't show off or overtake others in the group. A less experienced operator might try to do the same as you and fail. When riding with others, limit your abilities to the experience of others.
- In an emergency, the snowmobile engine can be stopped by pressing down on the emergency engine stop switch or by pulling the tether cord cap from the engine cut-off switch, while applying brake.
- Always engage parking brake when vehicle is not in use.
- Never run the engine in a non-ventilated area and/or if vehicle is left unattended.
- Never attempt any fuel system or electrical system maintenance or repair. Any maintenance or repair of these systems must be performed by an authorized Lynx dealer.
- Always remove the tether cord cap from engine cut-off switch when vehicle is not in operation in order to prevent accidental engine starting, to avoid unauthorized use by children or others or theft.
- NEVER stand behind or near a rotating track. Debris could be projected causing severe injuries. To remove packed snow or ice, stop engine, tilt and hold vehicle on its side and use wrench tool on the belt guard.
- Do not stud the track unless it has been approved for studs. At speed, a studded track that has not been approved for studs could tear and separate from vehicle. See an authorized Lynx dealer for current specific studding availability and applications.

SPECIAL SAFETY MESSAGES

- You may stud the track on this vehicle model. However, you **MUST** only use the BRP approved type stud for use on Lynx snowmobiles. **DO NOT EVER** use conventional studs because the track thickness is thinner than our standard tracks. The stud could tear off of track and separate from vehicle.
- Always wear an approved helmet and follow the same dressing guidelines as those recommended for the operator and described in this guide.
- Make sure that you are able to achieve a stable stance, both feet resting positively on the footboards of footrests with good grip, and that you are able to hold on firmly to the handholds.

RIDING THE VEHICLE

Each operator has a responsibility to ensure the safety of other recreationists or bystanders.

You are responsible for proper operation of your vehicle as well as training those whom you allow to ride or drive. There may be noticeable handling and performance differences from one snowmobile to the other.

A snowmobile is relatively simple to operate but like any other vehicle or mechanical equipment, it can be hazardous if you are reckless, thoughtless or inattentive. We encourage you to have an Annual Safety Inspection of your snowmobile. Please contact an authorized Lynx dealer for further details. Though not required, it is recommended that an authorized Lynx dealer performs the pre-season preparation of your snowmobile. Each visit to your authorized Lynx dealer is a great opportunity for your dealer to verify if your snowmobile is included in any safety campaign. We also urge you to visit your authorized Lynx dealer in a timely manner if you become aware of any safety related campaigns.

See an authorized Lynx dealer for available accessories you may require.

Before venturing on the trails, operate the snowmobile in a restricted flat area until you are completely familiar with its operation and feel comfortable that you can safely tackle a more demanding task. Have an enjoyable and safe ride.

Pre-Ride Inspection

WARNING

The pre-operation check is very important prior to operating the vehicle. Always check the proper operation of critical controls, safety features and mechanical components before starting.

Before Starting the Engine

1. Remove snow and ice from body including lights, seat, footrests, controls and instruments.
2. Verify that air silencer prefilter is free of snow.
3. Verify that skis and steering operate freely. Check corresponding action of skis versus handlebar.

4. Check fuel level and look for leaks. Replenish if necessary and in case of any leaks; you should seek service from an authorized Lynx dealer, repair shop, or person of your own choosing for maintenance and repair.
5. All storage compartments must be properly latched and they must not contain any heavy or breakable objects. Hood and side panels must be also properly latched.
6. Activate the throttle control lever several times to check that it operates easily and smoothly. It must return to idle position when released.
7. Activate the brake lever and make sure the brake fully applies before the brake control lever touches the handlebar grip. It must fully return when released.
8. Apply parking brake and check if it operates properly. Leave parking brake applied.
9. Inspect drive belt condition and height, refer to *DRIVE BELT* in *MAINTENANCE PROCEDURES*.

After Engine is Started

For proper engine starting procedure, refer to *ENGINE STARTING PROCEDURE*.

1. Check taillight, stop light and pilot lamps operation.

NOTE: You may need to detach tether cord from your clothes to check lights. In such a case, attach cord as soon as you get back at the controls of the snowmobile.

2. Check the engine cut-off switch (by pulling tether cord cap) and emergency engine stop switch operation.
3. Release parking brake.
4. Refer to *VEHICLE WARM UP* and follow instructions.

Pre-Ride Check List

ITEM	OPERATION	✓
BODY INCLUDING SEAT, FOOTRESTS, LIGHTS, AIR FILTER, CONTROLS AND INSTRUMENTS	Check condition and remove snow or ice.	
SKIS AND STEERING ACTION	Check for free movement and proper operation.	
FUEL	Check for proper level and no leaks.	
COOLANT	Check for proper level and no leaks.	
BRAKE FLUID	Check for proper level and no leaks.	
TRACK	Check condition and remove snow or ice. For studded tracks, refer to <i>TRACTION ENHANCING PRODUCTS</i> .	
THROTTLE LEVER	Check for proper operation.	
BRAKE LEVER	Check for proper operation.	
PARKING BRAKE, BRAKE	Check for proper operation.	
EMERGENCY ENGINE STOP SWITCH AND ENGINE CUT-OFF SWITCH (TETHER CORD CAP)	Check for proper action. Tether cord must be attached to operator clothing eyelet.	
LIGHTS	Check for proper operation.	
SKI RUNNERS	Check for proper operation.	
SLIDER SHOES	Check for proper operation.	
DRIVE BELT	Check for cracks, fraying or abnormal wear.	

How to Ride

This vehicle is developed exclusively for snocross competition. It is not intended for normal trail riding and not allowed on regular trails. Users have to have good understanding of the differences of this racing model.

This vehicle is intended for experienced riders only.

Rider Position (Forward Operation)

Your riding position and balance are the two basic principles of making your snowmobile go where you want it to. When turning on the side of a hill, you must be ready to shift body weight to help it turn in the desired direction. Operator must never attempt this maneuvering by placing feet outside of the vehicle. Experience will teach you how much lean to put into turns at different speeds and how much you will have to lean into a slope to maintain proper balance.

Generally, the riding position for best balance and control is sitting. However, the posting, kneeling or standing positions are also used under certain conditions.

WARNING

Do not attempt any maneuvers if they are beyond your abilities.

Sitting

Feet on the running boards, body midway back on seat is an ideal position when operating the snowmobile over familiar, smooth terrain. Knees and hips should remain flexible to absorb shocks.



Posting

A semi-sitting position with the body off the seat and the feet under the body in a sort of squatting posture, thus allowing the legs to absorb the shocks when traveling over uneven terrain. Avoid abrupt stops.



Kneeling

This position is achieved by placing one foot firmly on the running board and the opposite knee on the seat. Avoid abrupt stops.



Standing

Place both feet on the running boards. Knees should be flexed to absorb the shock from surface bumps. This is an effective position to see better and to shift weight as conditions dictate. Avoid abrupt stop.



mno2008-003-004

TRACTION ENHANCING PRODUCTS

NOTE: This section is applicable to snowmobiles equipped with a factory installed track that has been approved by BRP for special studs installation.

WARNING

Never stud a track that has not been approved for studs. Installing studs on an unapproved track could increase the risk of the track tearing or severing.

WARNING

You may stud the track on this vehicle model. However, you **MUST** only use the BRP approved type stud for use on these Lynx snowmobiles. The stud could tear off of track and separate from vehicle. See an authorized Lynx dealer for current specific studding availability and applications.

Using traction enhancing products such as, adjustable or more aggressive ski carbide runners and/or studs on your snowmobile will change its behavior, particularly in terms of manoeuvrability, acceleration, and braking.

Using traction enhancing products gives a better grip on packed snow and ice, but has no noticeable effect on soft snow. For this reason, driving a snowmobile equipped with traction enhancing products requires a certain adaptation period. If your snowmobile is equipped with traction enhancing products, be sure to take plenty of time to get used to the way it handles when turning, accelerating, and braking.

Also, always check local regulations concerning the use of traction enhancing products on snowmobiles. Always drive your snowmobile in a responsible manner, respecting the environment and other people's property.

Manoeuvrability

Using traction enhancing products such as, more aggressive ski carbide runners and/or studs makes the snowmobile grip the ground better at both the front and at the rear. The use of carbide runners is therefore required to give the skis a better grip, so that the front and rear of the snowmobile are in balance. While off-the-shelf carbide ski runners are adequate, they don't necessarily give you optimal control, since that depends on your personal preferences, your riding style, and how your suspension is adjusted.

⚠ WARNING

If the front and rear of the snowmobile are out of balance due to an incorrect combination of traction enhancing products, the snowmobile may tend to oversteer or understeer, which could lead to a loss of control.

Oversteering

In certain conditions, using more aggressive ski carbide runners without studs on the rear track could make the snowmobile prone to oversteering, see illustration.

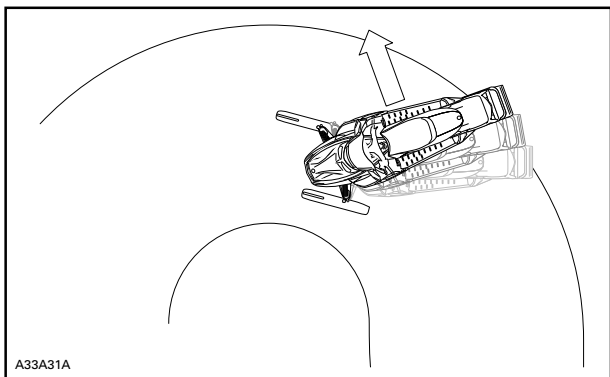
**OVERSTEERING****Understeering**

In certain conditions, the use of studs on the track could make the snowmobile prone to understeering if the skis are not equipped with more aggressive ski carbide runners, see illustration.

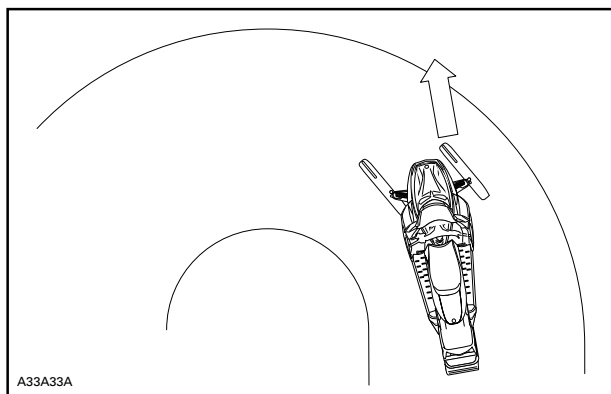

UNDERSTEERING

Controlled Driving

A balanced combination of carbide ski runners and studs on the track ensures adequate control and better handling, see illustration.

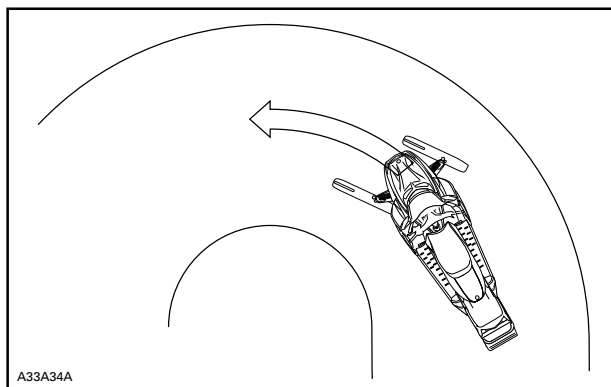

CONTROLLED DRIVING

Acceleration

Using studs on the track will allow your sled to accelerate better on packed snow and ice but will have no noticeable effect on soft snow. This can cause sudden variations in traction under certain conditions.

WARNING

To prevent surprises that could lead to a loss of control of the snowmobile:

- Always go easy on the throttle.
- NEVER try to spin the track to make the rear of the snowmobile skid.

This could cause debris or ice to be thrown violently backwards, possibly injuring others nearby or on snowmobiles behind you.

Braking

As in the case of acceleration, using studs on the track will give you better braking capacity on packed snow or ice but will have no noticeable effect on soft snow. Braking may thus vary suddenly under certain conditions. Be sure to use restraint in braking to keep from blocking the track in order to avoid surprises that could lead to a loss of control.

Important Safety Rules

WARNING

To prevent serious injury to individuals near the snowmobile:

- NEVER stand behind or near a moving track.
- Always use a wide-base snowmobile stand with a rear deflector panel if it is necessary to rotate track.
- When the track is raised off the ground, only run it at the lowest possible speed.

Centrifugal force could cause debris, damaged or loose studs, pieces of torn track, or an entire severed track to be violently thrown backwards out of the tunnel with tremendous force.

Effects of Having a Studded Track on the Life of the Snowmobile

The use of traction enhancing products can increase the load and the stress on certain snowmobile components, as well as the vibration level. This can cause premature wear on parts such as belts, brake linings, bearings, chain, chaincase sprocket, and on approved studded tracks, shorten track life. Always proceed with a visual inspection of your track before each use. For more information, refer to *TRACK* in *MAINTENANCE*.

Studs on the track can also cause serious damage to your snowmobile if it is not equipped with the tunnel protectors designed for your particular model. Damage to the electrical wiring or perforation of the heat exchangers are potential hazards, that could cause the engine to overheat and be severely damaged.

WARNING

If tunnel protectors are excessively worn or not installed, the gas tank could be punctured, causing a fire.

NOTICE Ask your dealer for the appropriate tunnel protectors model and kit number required for your snowmobile.

NOTE: Consult the BRP limited warranty to find out what warranty limitations are related to the use of studs.

Installation of Studs on BRP Approved Tracks

WARNING

Never stud a track that has not been approved for studs. Approved tracks can be identified by a stud symbol (see illustration below) molded into the track surface. Installing studs on an unapproved track could increase the risk of the track tearing or severing.

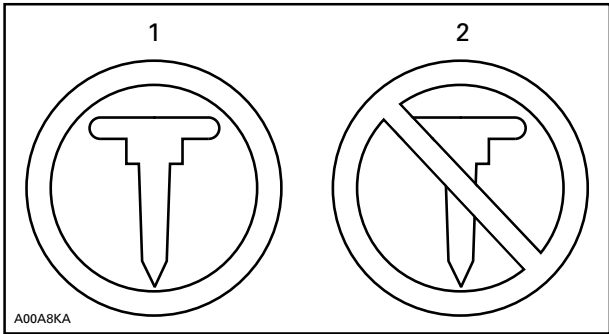

TRACK SYMBOLS

1. *Approved*
2. *NOT Approved*

To ensure safe and proper installation, BRP recommends to have the studs installed by your dealer.

- Use only the BRP approved special studs.
- Never use studs that exceed the height of your snowmobile's track profile by more than 9.5 mm (3/8 in).

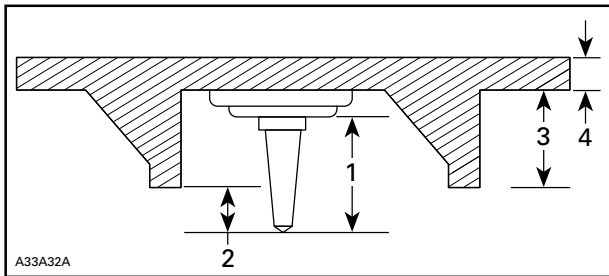

INSTALLATION OF STUDS

1. *Stud size*
2. *Penetration range 6.4 mm to 9.5 mm (1/4 in to 3/8 in)*
3. *Track lug height*
4. *Track belt thickness*

NOTE: All Radien models need to have stud protector installed on front and rear parts of the radiator if studs are used.

 **WARNING**

- See an authorized Lynx dealer for current specific studding availability and applications.
- Studs should only be installed in the locations indicated by molded bulges in the track surface. Some track models have two types of molded bulges; triangles and circles. See the warning molded into the track surface to know which one to use.
- Never stud a track with a profile of 35 mm (1-3/8 in) or more.
- The number of studs installed must always perfectly match the pattern of molded bulges in the track.
- Always consult the traction product manufacturer's installation instructions and recommendations before having your dealer install studs and runners. It is very important to follow the torque specifications for the stud bolts.

INSTALLING AN INCORRECT NUMBER OF STUDS OR AN IMPROPER INSTALLATION CAN INCREASE THE RISK OF THE TRACK TEARING OR SEVERING.

Maintenance/Replacement

PROCEED WITH A VISUAL INSPECTION OF YOUR TRACK BEFORE EACH USE.

Look for any defects, such as:

- Perforations in the track
- Tears in the track (particularly around traction holes on studded tracks)
- Lugs that are broken or torn off, exposing portions of rods
- Delamination of the rubber
- Broken rods
- Broken studs (studded tracks)
- Bent studs (studded tracks)
- Missing studs
- Studs that are torn off the track
- Missing track guide(s)
- Also, ensure that studs nut are tighten to the recommended torque.

On approved studded tracks, replace broken or damaged studs immediately. If your track shows signs of deterioration, it must be replaced immediately. When in doubt, ask your dealer. Always proceed with a visual inspection of your track before each use.

WARNING

Riding with a damaged track or studs could lead to loss of control.

IMPORTANT ON-PRODUCT LABELS

Hang Tag(s)



Dear consumer,

Your new E-TEC engine technology has an automatic computer-controlled break-in period that ensures you get the most performance, efficiency and reliability for the life. During the break-in, it will consume more oil and fuel than normal. Also, you may feel the engine misfire. This is normal, the computer is protecting the engine components against premature wear and ensure optimal break-in. After this period, which lasts for about the first two tanks of fuel (22 gal./80 l), you'll be able to experience the unmatched performance, fuel and oil economy that only the E-TEC technology delivers.



Cher client,

Votre nouveau moteur à technologie E-TEC a une période de rodage contrôlée automatiquement qui assurera une performance, une efficacité et une fiabilité optimales à long terme. Durant la période de rodage, le moteur consommera plus d'huile et d'essence qu'à la normale. Ainsi, il se peut que le moteur ait des ratés. Cela est normal puisque le module de commande protège le moteur contre l'usure prématurée et assure un rodage optimal. Après cette période, qui dure environ 2 pleins d'essence (80 l), vous serez en mesure de profiter pleinement des performances, ainsi que de la faible consommation d'huile et d'essence, que seule la technologie E-TEC peut offrir.

516004621

516004621



CAUTION

This snowmobile is calibrated for operating at SEA-LEVEL. Operating above 2000 ft requires calibration parts and adjustment. For more details, REFER to your Operator's Guide that came with your snowmobile or see your authorized Ski-Doo dealer. **INCORRECT ADJUSTMENTS MAY CAUSE PARTS DAMAGE**

mmo2008-003-054_en

Vehicle Safety Labels

These labels are affixed to the vehicle for the safety of the operator or bystanders.

The following labels are on your vehicle and they should be considered permanent parts of the vehicle. If missing or damaged, the decals can be replaced free of charge. See an authorized Lynx dealer.

NOTE: In the event of any discrepancy between this guide and the vehicle, the safety labels on the vehicle have precedence over the labels in this guide.

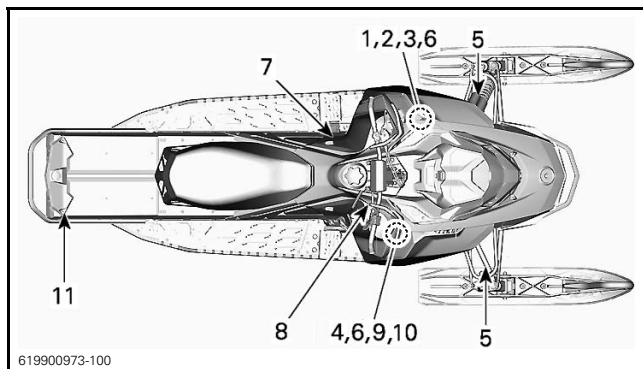

Label 1

Toujours débrancher les
connecteurs électriques
des deux injecteurs
d'essence avant de
vérifier la production
d'étincelles. Autrement,
une étincelle pourrait
allumer des vapeurs
d'essence, ce qui
représenterait un risque
de feu.

AVERTISSEMENT



WARNING

Always electrically
disconnect
both fuel injectors prior to
testing for ignition spark.
Otherwise, fuel vapors
may ignite in presence of
a spark creating a fire
hazard.

516007661

EN-516007661-DEC

LABEL 1

Label 2

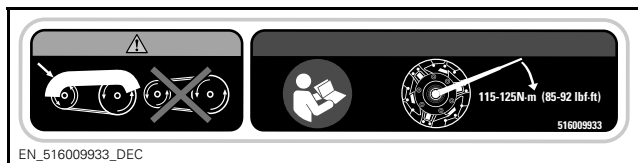

LABEL 2

Label 3

! WARNING

- Locate and read operator's guide. Follow all instructions and warnings.
- Beware of hot parts.
- Beware of hot vapors.
- Do not use without pulley guard.
- Beware of drive belt.
- Read instructions before service.

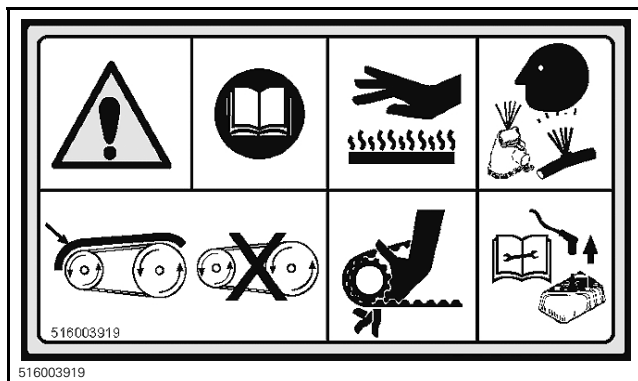

LABEL 3

Label 4



LABEL 4

Label 5

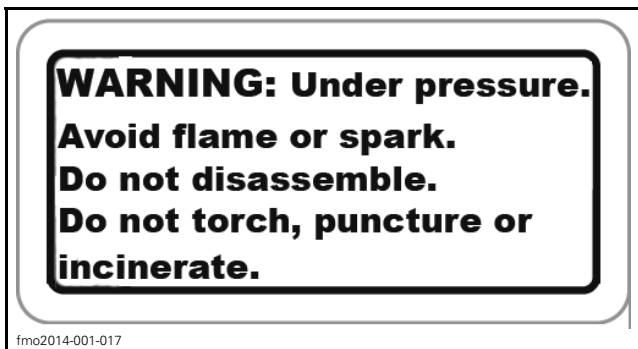

LABEL 5- ON APPLICABLE SHOCK ABSORBERS

IMPORTANT ON-PRODUCT LABELS

Label 6

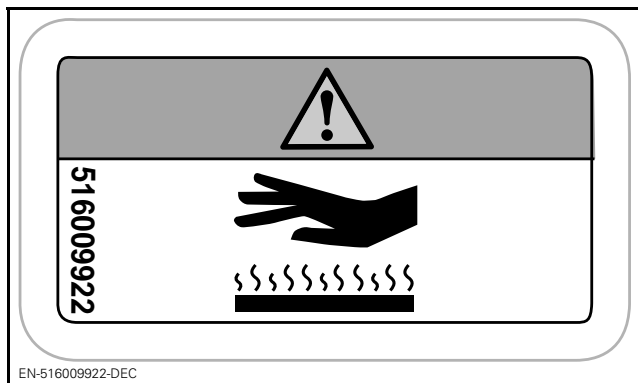

LABEL 6

Label 7

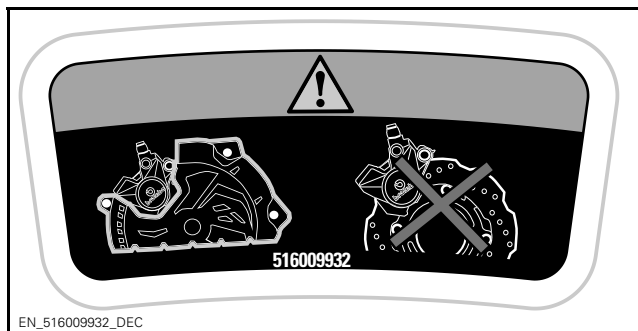

LABEL 7

Label 8

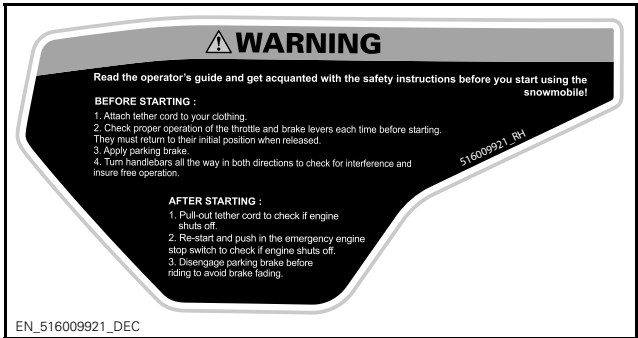

LABEL 8

Label 9



LABEL 9

Label 10

<p>▲ WARNING</p> <p>Capacitor May Spark If Shorted. - Spark can ignite fuel vapors. - Keep objects away from poles. - When removing from vehicle, always discharge properly.</p>	<p>CAPACITOR</p>  <p>CONDENSATEUR</p>	<p>▲ AVERTISSEMENT</p> <p>Le condensateur peut produire une étincelle si court-circuité.</p> <ul style="list-style-type: none">- Une étincelle peut enflammer les vapeurs d'essence.- Garder tout objet éloigné des bornes.- Si démonté du véhicule, toujours décharger adéquatement.
---	---	--

EN-516008593-DEC_44piH

LABEL 10

Label 11

⚠ WARNING

- Do not lift the vehicle using the snow guard.
- NEVER stand behind or near a rotating track. Debris could be projected causing severe injuries. To remove packed snow/ice, stop engine, lift and hold vehicle on the side and use wrench tool on the belt guard.
- NEVER sit in cargo area



LABEL 11

***This page is
intentionally blank***

VEHICLE INFORMATION

CONTROLS, INSTRUMENTS AND EQUIPMENT

Some features may not apply to your model or could be optional.

Some vehicle safety labels are not shown on illustrations. For information on vehicle safety labels, refer to *IMPORTANT ON-PRODUCT LABELS*.

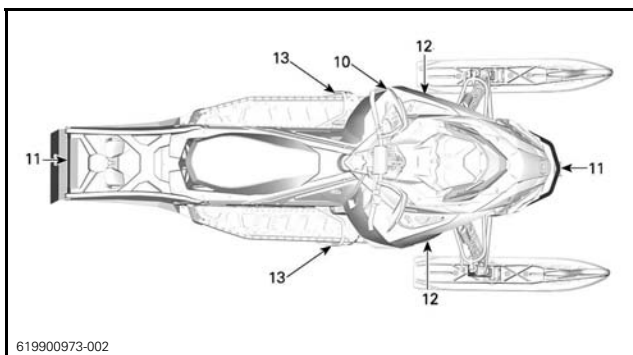
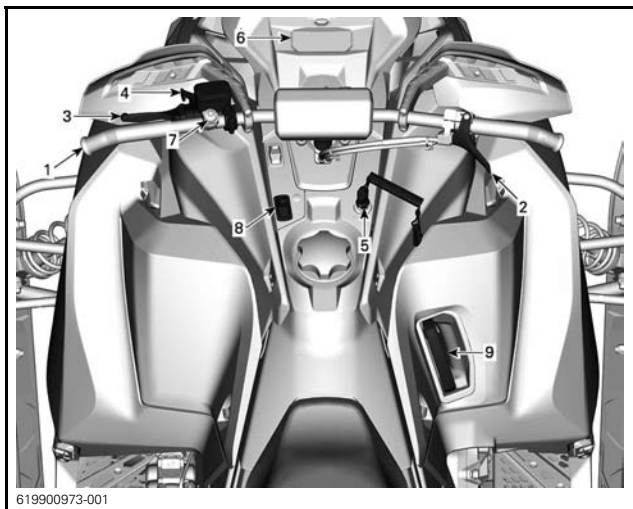

1) Handlebar

The handlebar controls the steering of the snowmobile. As the handlebar is rotated to right or left, the skis are turned right or left to steer the snowmobile.

2) Throttle Lever

Throttle lever is located on the RH side of handlebar.

Designed to be thumb activated. When squeezed, it increases the engine speed. When released, engine speed returns automatically to idle.

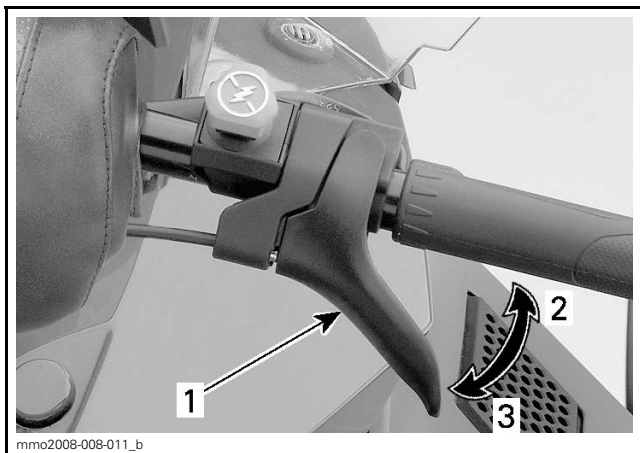

TYPICAL

1. Throttle lever
2. To accelerate
3. To decelerate

WARNING

Test the throttle lever operation each time before starting the engine. The lever must return to the rest position once released. Otherwise, do not start engine.

3) Brake Lever

Brake lever is located on the LH side of handlebar.

When squeezed, brake is applied. When released, it automatically returns to the rest. Braking effect is proportional to the pressure applied on the lever and to the type of terrain and its snow coverage.

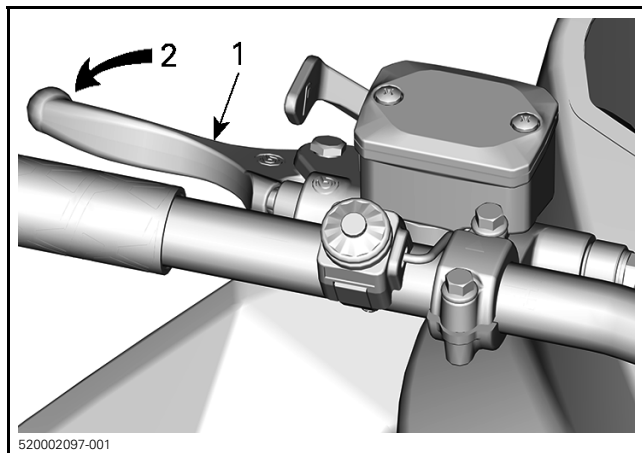

TYPICAL

1. Brake lever
2. To apply brake

4) Parking Brake Lever

Parking brake lever is located on the LH side of handlebar.

Parking brake should be used whenever snowmobile is parked.

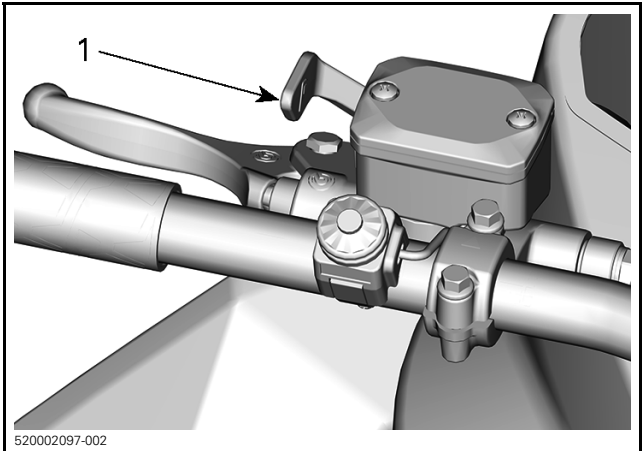

520002097-002

TYPICAL

1. Parking brake lever

⚠ WARNING

Make sure parking brake is fully disengaged before operating the snowmobile. When you ride the vehicle, brake pads that are caused to drag by a continuous pressure on the lever may cause damage to the brake system and cause loss of braking capacity and/or fire.

To Engage Parking Brake

Apply and hold brake, then lock brake lever using the parking brake lever as shown.

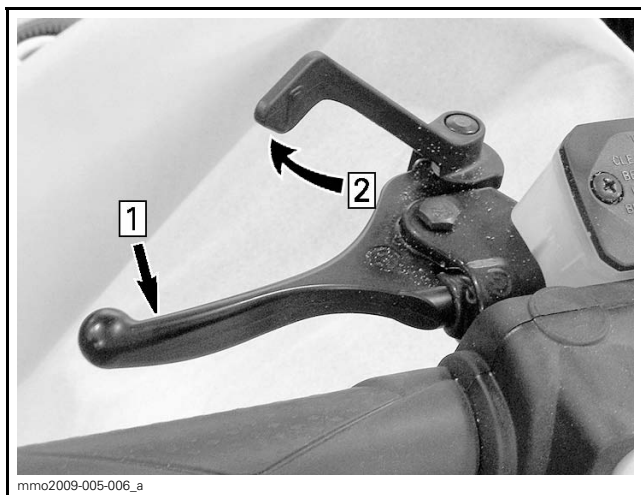

TYPICAL — ENGAGE MECHANISM

Step 1: Apply and hold brake

Step 2: Lock brake lever using parking brake lever

To Release Parking Brake

Squeeze brake lever. Parking brake lever will automatically return to its original position. Always release parking brake before riding.

5) Engine Cut-off Switch

The engine cut-off switch (tether cord) is located on the console.

The tether cord cap must be securely snapped on the engine cut-off switch to allow vehicle operation.

Pulling the tether cord cap from the switch shuts the engine off.

WARNING

Always attach the tether cord eyelet to clothing before starting the engine.

NOTE: The D.E.S.S. (Digitally Encoded Security System) can be enabled if desired. Contact an authorized Lynx dealer.

6) Multifunction Digital Gauge

⚠ WARNING

Reading the gauge digital display can distract from the operation of the vehicle, particularly from constantly scanning the environment.

NOTE: The gauge is factory preset in Imperial units and in English. To change units or language, contact an authorized Lynx dealer.

Gauge Features

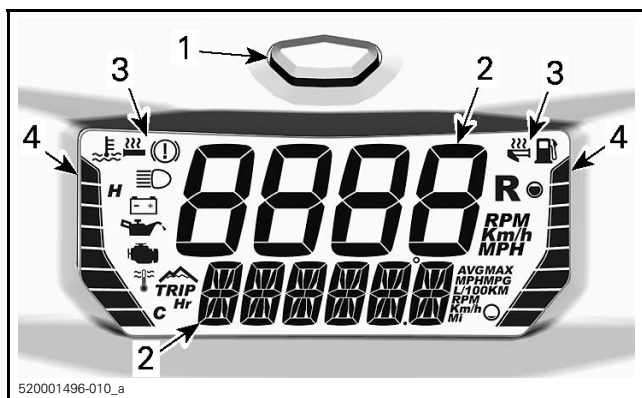

MULTIFUNCTION DIGITAL GAUGE

1. Mode button
2. Digital displays
3. Icons
4. Bar gauges

The gauge also has a built-in beeper.

Digital Display

⚠ WARNING

Never adjust or set functions on the multifunction gauge while riding the vehicle.

To set the displays to your preference, see *DISPLAY COMBINATION SELECTION*.

Upper Display

The upper display is used to display:

- Vehicle speed.
- Engine speed (RPM).

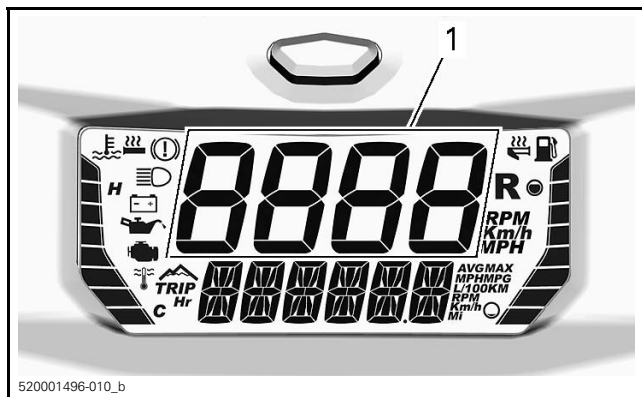

1. Upper Display

Lower Display

The lower display is used to display

- Various information (in combination with the upper display)
- Messages, see *ICONS AND MESSAGES* and *MONITORING SYSTEM* for details.
- Fault codes, see *MONITORING SYSTEM* for details.

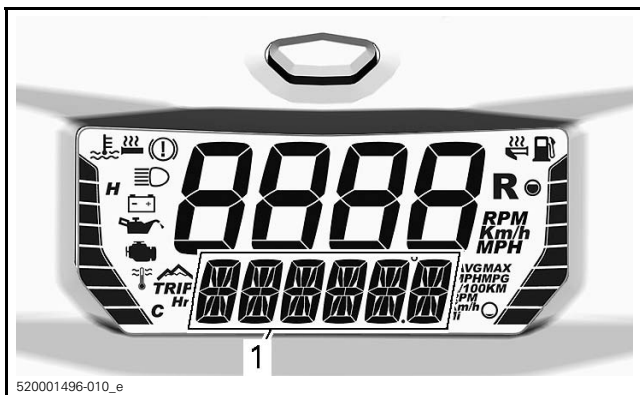

1. Lower display

LH side Bar Gauge

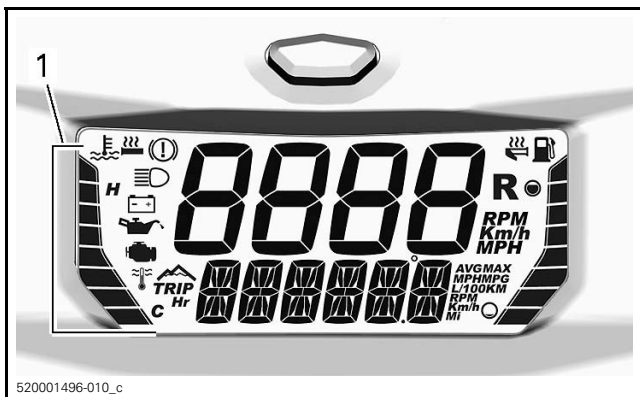

1. LH bar gauge

LH BAR GAUGE INFORMATION

Engine coolant temperature

Heated grips level

Lap (in lap record mode)

The LH side bar gauge displays the engine coolant temperature except while adjusting the heating elements.

NOTICE If engine overheats, stop vehicle in a safe place. Refer to TROUBLESHOOTING.

For details on heated grips operation, see *HEATED GRIPS AND THROTTLE LEVER SWITCH* in this section.

RH side Bar Gauge

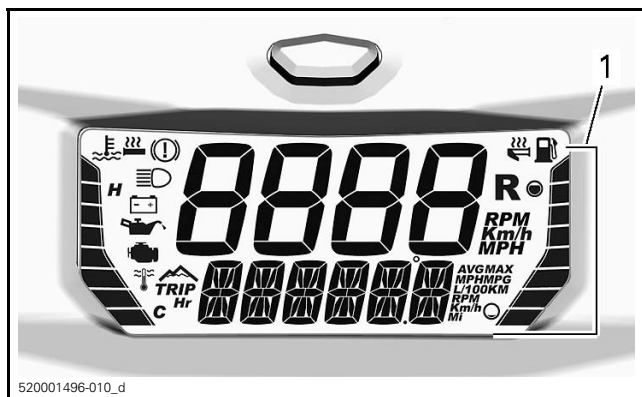

1. RH bar gauge

LH BAR GAUGE INFORMATION

Heated throttle lever level

Record or playback telltale (in lap record mode)

For details on heated throttle lever operation, see *HEATED GRIPS AND THROTTLE LEVER SWITCH* in this section.

Display Combination Selection

The upper display can show the vehicle speed or engine speed (RPM). To change the setting, press and hold the gauge button while the desired parameter is displayed.

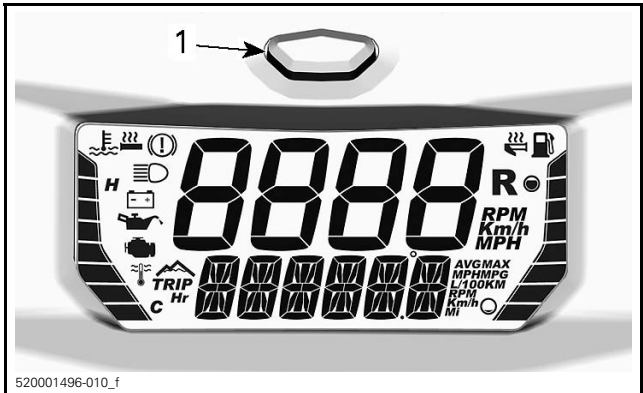

1. Gauge mode button

See the following table for available combinations.

AVAILABLE DISPLAY COMBINATIONS				
	UPPER DISPLAY	ICON/ SPECIFIC INFORMATION	LOWER DISPLAY	ICON/ SPECIFIC INFORMATION
1	Vehicle speed OR Engine speed	Km/h or MPH OR RPM	Vehicle speed OR Engine speed	Km/h or MPH OR RPM
2			Odometer	Km or MI
3			Trip odometer A(1)	TRIP Km or MI
4			Trip odometer B (1) (2)	TRIP Km or MI
5			Trip hour (1)	TRIP Hr
6			Top speed (1)	MAX Km/h or MPH
7			Average speed (1)	AVG Km/h or MPH

8	Vehicle speed OR Engine speed	Km/h or MPH OR RPM	Top RPM (1)	MAX RPM
9			Average fuel consumption	AVG L/100Km or MPG
10			Engine coolant temperature	E and C or F
11			Tuned pipe temperature	T and C or F
(1) Press and hold the mode button to reset (2) Resetting the trip odometer B also resets the average fuel consumption				

NOTE: Make sure to display the vehicle speed whenever this information is necessary.

Icons and Messages

See table below for usual icons and messages.

For details on malfunction pilot lamps and messages, refer to *MONITORING SYSTEM*.

ICON	BEEPER	MESSAGE LOWER DISPLAY	DESCRIPTION
—	—	BREAK-IN	Displayed during break-in period. See <i>BREAK-IN PERIOD</i>
	—	—	High beam headlights are selected.
—	—	WARM UP	Engine and/or injection oil need to warm-up before normal operation. The engine's RPM is limited until desired temperature is reached (up to 10 minutes when driving). Warm-up period may occur after a restart in very cold weather.

NOTE: Additional function may be available for your vehicle, see the appropriate Lynx accessory catalog.

Lap Record Mode

Entering Lap Record Mode

To enter the lap record mode:

- Select the odometer. Refer to *DISPLAY COMBINATION SELECTION*
- Press and HOLD the mode button.

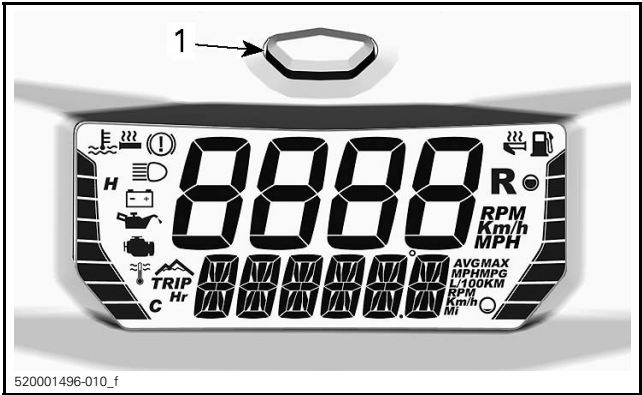

1. Gauge mode button

To navigate through the functions (RECORD, PLAY or SELECT), repeatedly push DOWN on the heating elements (heated grips and throttle lever) switch.

NOTE: It is not possible to adjust the heating elements level while in Lap Record Mode.

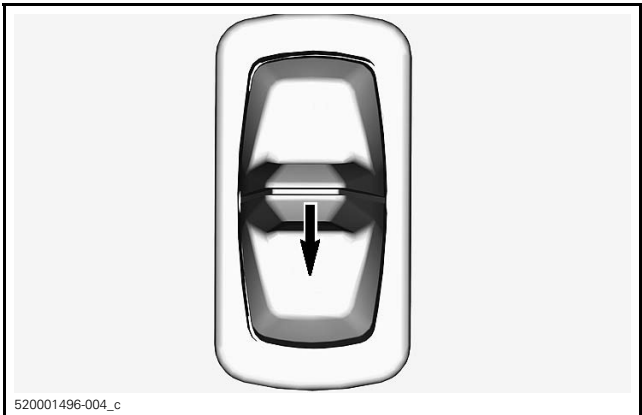

PUSH DOWN TO NAVIGATE THROUGH FUNCTIONS

Exiting Lap Record Mode

To exit the lap record mode, press the mode button.

Selecting Information on Lower Display (SELECT)

The information recorded by default are:

- Engine speed (RPM) on the upper display
- Vehicle speed on the lower display.

The upper display always records the engine speed (RPM) but the lower display can record one of the following:

- Odometer (resets to 0 at each new recording)
- Vehicle speed
- Top speed (resets to 0 at each new recording)
- Top RPM (resets to 0 at each new recording)
- Engine coolant temperature (if equipped).

To change the information to be recorded on the lower display:

- Enter the lap record mode
- Choose the SELECT function, by repeatedly pushing DOWN the heating elements switch.
- Push the heating elements switch UP once to activate the SELECT mode.
- To choose the information to be recorded, repeatedly push DOWN the heating elements switch.
- To confirm the selection, push UP the heating elements switch (the word "SELECT" will be displayed to confirm the selection).

NOTE: Once the selection is made, you have 15 seconds to confirm it. Otherwise, the selection will be cancelled.

You can now record the selected information.

Recording Information (RECORD)

To record information:

- Enter the lap record mode
- Enter the RECORD function, by repeatedly pushing DOWN the heating elements switch
- To start recording, push UP the heating elements switch
- To pass to the following lap (following recording), push UP the heating elements switch
- To stop recording, push DOWN the heating elements switch.

While recording, one bar of the RH bar gauge constantly moves upwards to indicate the gauge is currently recording.

The LH bar gauge acts as a lap counter. One bar means first lap, two bars means second lap, and so on. A maximum of 8 laps can be recorded.

If the memory reaches its maximum capacity, the recording will stop by itself.

Playing Back a Recorded Lap (PLAY)

To playback a recording:

- Enter the lap record mode
- Enter the PLAY function, by repeatedly pushing DOWN the heating elements switch
- To start a playback, push UP the heating elements switch
- To pass to the following lap (following recording), push UP the heating elements switch
- To stop a playback, push DOWN the heating elements switch.

If no action is taken during playback, each turn will be displayed one after the other until the end of the recordings.

While playing back, one empty bar of the RH bar gauge constantly move upwards to indicate the gauge is currently playing back.

The LH bar gauge acts as a lap counter. One bar means first lap, two bars means second lap, and so on.

7) Exhaust Tuned Pipe Preheat Button

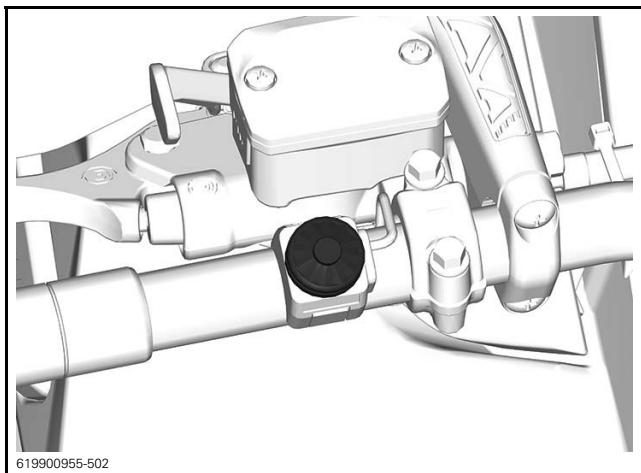

1. Preheat button

After starting the engine, push and hold the button in order to preheat the exhaust tuned pipe.

Release the button once the tuned pipe has warmed up.

8) Heated Grips and Throttle Lever Switch

The heated throttle lever and heated grips are adjusted simultaneously using the switch.

There are 4 intensity settings. To set, press and release the switch repeatedly until the desired setting is obtained.

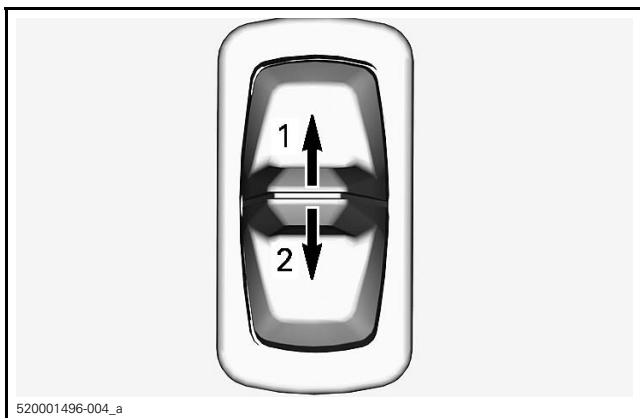

520001496-004_a

1. Increase heat
2. Decrease heat

The setting is displayed on the bar gauges of the multifunction digital gauge. See *MULTIFUNCTION DIGITAL GAUGE* in this section.

To shut off, press the button down until the bar gauge is empty.

NOTE: If the balance between the temperature of the throttle lever and the grips does not suit you, it is possible to adjust it. Contact an authorized Lynx dealer.

9) Rewind Starter Handle

Auto-rewind type located on right hand side of snowmobile. To engage mechanism, pull handle slowly until a resistance is felt then pull vigorously. Slowly release handle.

NOTE: The maximum torque that can be transmitted to the engine by the rewind starter is 80 N•m (59 lbf•ft). The maximum force that can be exerted on the on the rope is 2 200 N (494.6 lbf).

10) Drive Belt Guard

Drive Belt Guard Removal

WARNING

NEVER operate engine:

- Without shields and belt guard securely installed.
- With hood and/or side panels opened or removed.

NEVER attempt to make adjustments to moving parts while engine is running.

NOTE: Belt guard is purposely made slightly oversize to maintain tension on its pins and retainers preventing undue noise and vibration. It is important that this tension be maintained when reinstalling.

Remove tether cord cap from engine cut-off switch.

Open the LH side panel. See procedure in this section.

Remove retaining pin.

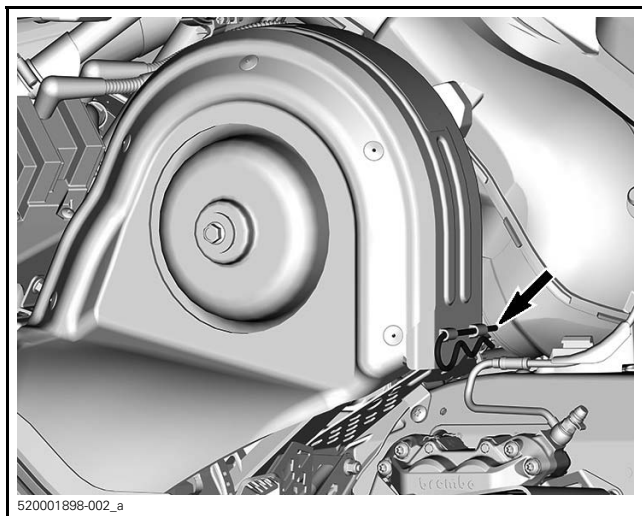

Lift rear portion of guard then release from front tab.

Drive Belt Guard Installation

Insert the tab into the slot and push it into place

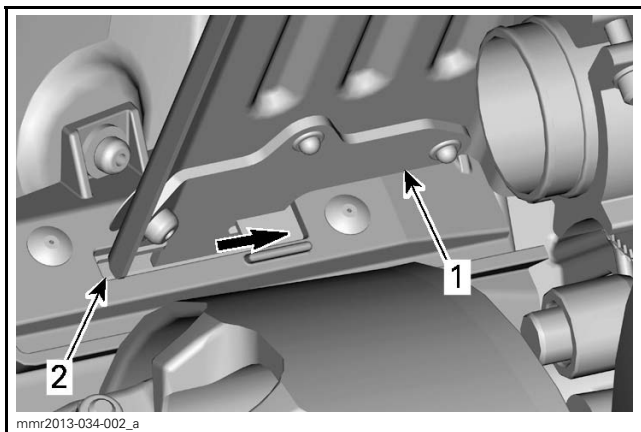

mnr2013-034-002_a

1. Belt guard tab
2. Front support slot

Push drive belt guard toward engine then toward front of vehicle.

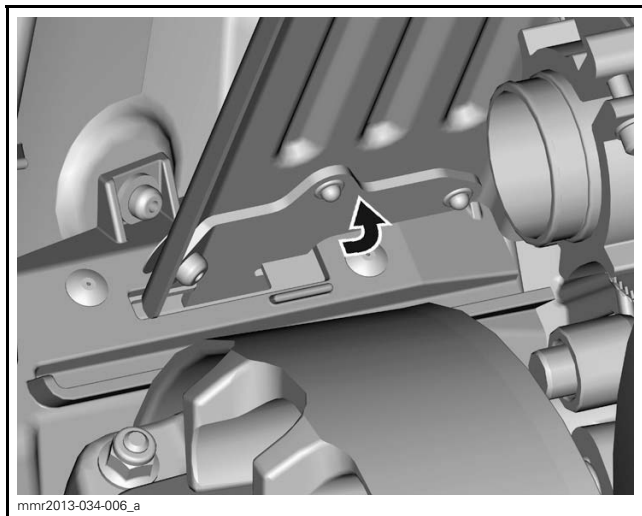

Position the rear portion of the belt guard over the retainer and secure it using the retaining pin.

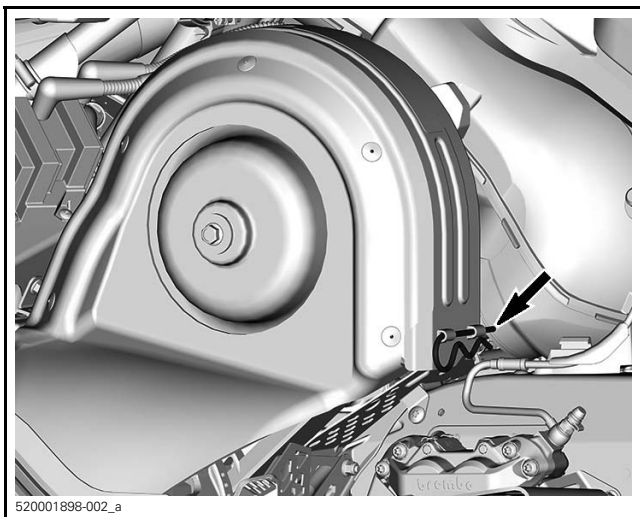

11) Front and Rear Bumpers

To be used whenever snowmobile requires manual lifting.

⚠ CAUTION Beware of injuries by using proper lifting techniques, notably by using the force of your legs. Do not attempt to lift the rear of vehicle if it is above your limits. Use appropriate lifting device or have assistance to share lifting stress if possible.

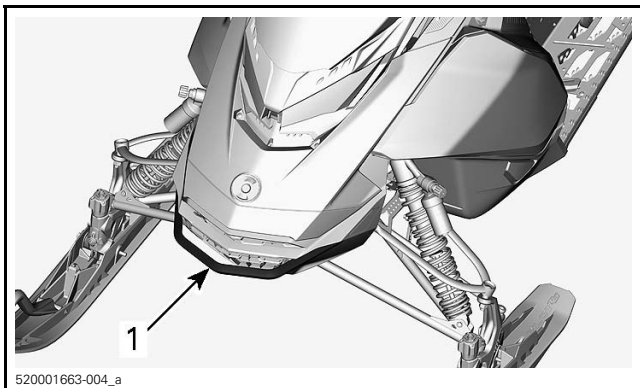

TYPICAL

1. Front bumper

NOTICE Do not use skis to pull or lift snowmobile.

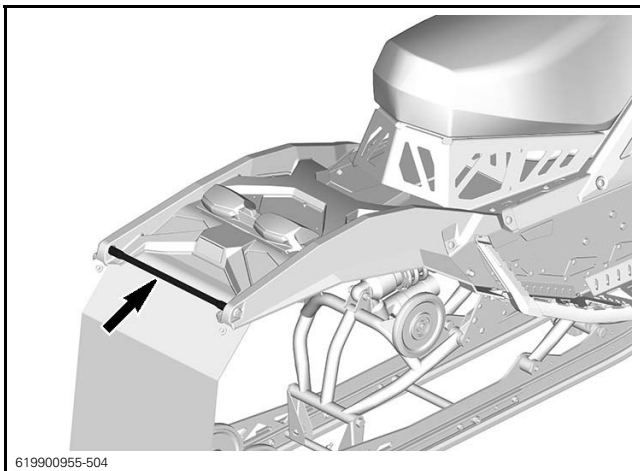

NOTICE

- Do not use the rear bumper to lift the rear when the vehicle is stored.
- Do not use the rear bumper to secure the vehicle when transporting.
- Do not use the rear bumper to tow.

To lift rear of vehicle, pass lifting strap as shown.

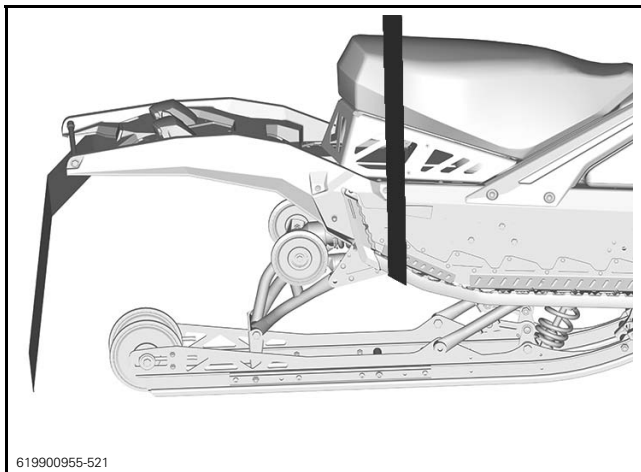

12) Side Panels

⚠ WARNING

Never operate engine with side panels opened or removed from vehicle.

Side Panels Opening and Closing

Release all latches, then open panel.

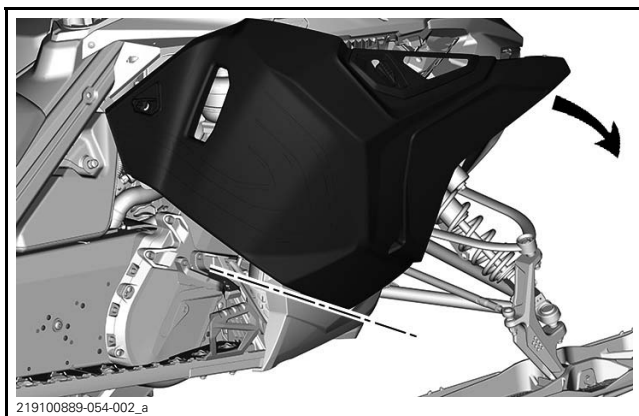
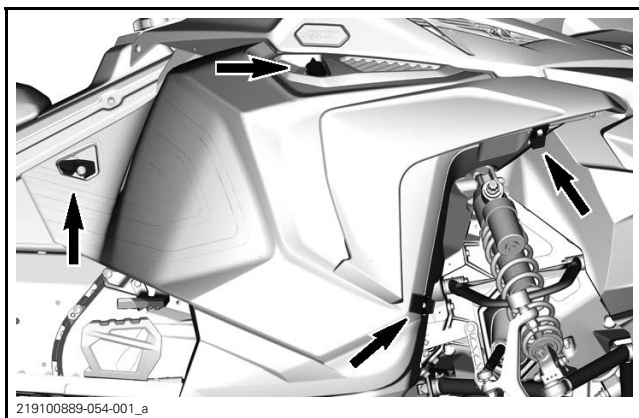

When closing panel, make sure latches are locked securely.

Side Panels Removal

Open side panel.

Lift the side panel to disengage the tabs.

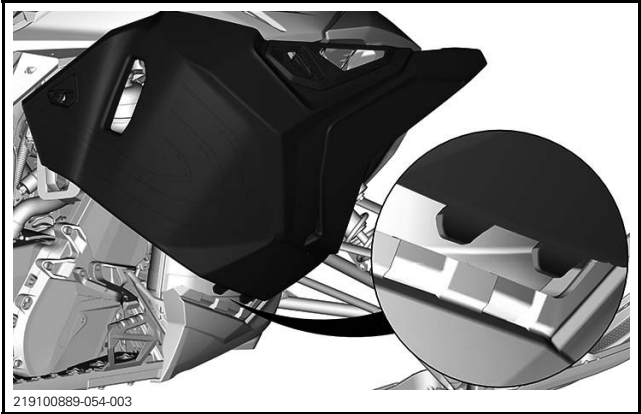

13) Footrests

The footrests are adjustable.

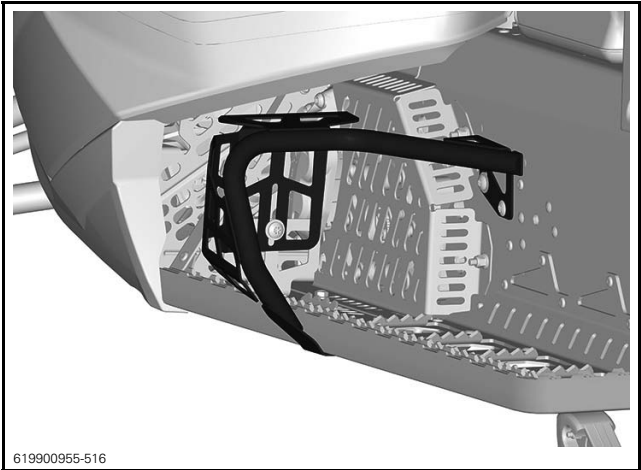

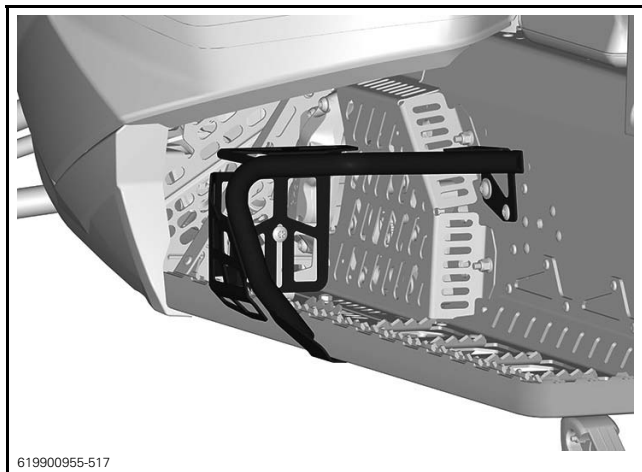

To adjust proceed as follow:

1. Slightly loosen mounting screws, do not remove.
2. Adjust height at desired position.
3. Tighten mounting screws.

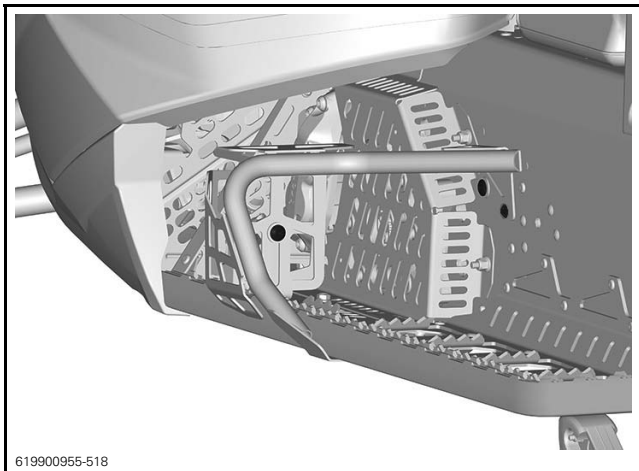

619900955-518

MOUNTING SCREWS

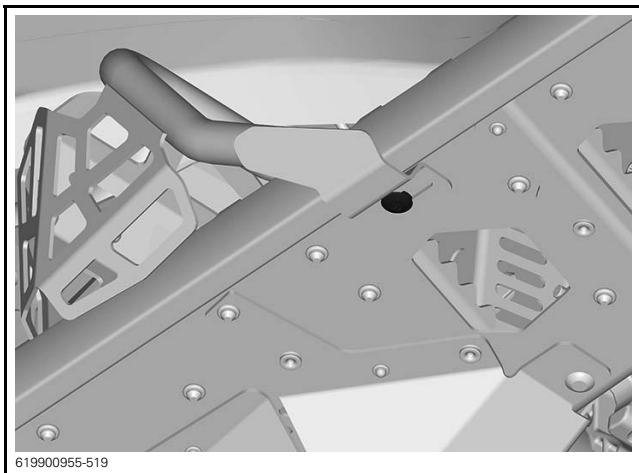

619900955-519

MOUNTING SCREW

FUEL AND OIL

Fuel Requirements

NOTICE Always use fresh gasoline/oil mix. Gasoline will oxidize; the result is loss of octane, volatile compounds, and the production of gum and varnish deposits which can damage the fuel system. Mix the appropriate oil with the gasoline in the recommended ratio.

Alcohol fuel blending varies by country and region. Your vehicle has been designed to operate using the recommended fuels, however, be aware of the following:

- Use of fuel containing alcohol above the percentage specified by government regulations is not recommended and can result in the following problems in the fuel system components:
 - Starting and operating difficulties.
 - Deterioration of rubber or plastic parts.
 - Corrosion of metal parts.
 - Damage to internal engine parts.
- Inspect frequently for the presence of fuel leaks or other fuel system abnormalities if you suspect the presence of alcohol in gasoline exceeds the current government regulations.
- Alcohol blended fuels attract and hold moisture which may lead to fuel phase separation and can result in engine performance problems or engine damage.

Recommended Fuel

Use unleaded gasoline containing MAXIMUM 10% ethanol. The gasoline must have the following minimum octane requirements.

FUEL TYPE	ENGINE	MIN. OCTANE RATING
Fuel with NO ethanol	600RS E-TEC	93 AKI (RON+MON)/2 98 RON
Fuel which may contain up to 10% MAX ethanol	600RS E-TEC	93 AKI (RON+MON)/2 98 RON

NOTICE Never experiment with other fuels. Engine or fuel system damages may occur with the use of an inadequate fuel.

NOTICE Do NOT use fuel from fuel pumps labeled E85.

Use of fuel labeled E15 is prohibited by U.S. EPA Regulations.

Fuel Antifreeze Additives

When using oxygenated fuel, additional gas line antifreeze or water absorbing additives are not required and should be not used.

When using non-oxygenated fuel, isopropyl base gas line antifreeze can be used in a proportion of 150 ml (5 U.S. oz) of gas line antifreeze added to 40 L (10.6 U.S. gal.) of gas.

This precaution is in order to reduce the risk of frost buildup in fuel system components which may lead, in certain cases, to severe damage to engine.

NOTE: Use only methyl hydrate free gas line antifreeze.

Recommended Oil

This vehicle has no injection oil pump.

The gasoline must be thoroughly mixed with oil at the ration of 33:1 in a fuel can first, then be poured in the vehicle fuel tank.

PREMIX FUEL/OIL RATIO
33:1

Premix Fuel/Oil Ratio

PROPER RATIO OF 33:1
16.5L of fuel + 500ml of oil
5 U.S. gallon of fuel + 19.4 U.S. ounce of oil
5 imperial gallon of fuel + 24.2 imperial ounce of oil

Recommended Premix Oil

RECOMMENDED PREMIX OIL	
Scandinavia	2T X2-RS RACING SYNTHETIC OIL (EUR) (P/N 779228)
All other countries	2T X2-RS RACING SYNTHETIC OIL (P/N 779180)

NOTICE The engine was developed and validated using the X2-RS - 2T Synthetic Racing Engine Oil. BRP strongly recommends the use of this oil at all times. Never experiment other fuel/oil ratios. Damages caused by not suitable oil for the engine or incorrect fuel/oil ratio will not be covered by the BRP limited warranty.

Vehicle Fueling Procedure

WARNING

Always stop engine before refueling.

WARNING

- Fuel is flammable and explosive under certain conditions.
- Never use an open flame to check fuel level.
- Never smoke or allow flame or spark in vicinity.
- Always work in a well-ventilated area.

1. Stop engine.
2. Have operator get off vehicle.

WARNING

Do not allow anyone seated on the vehicle while fueling.

3. Unscrew slowly the fuel reservoir cap counterclockwise to stabilize pressure before removing it.

NOTE: A short whistling sound is normal.

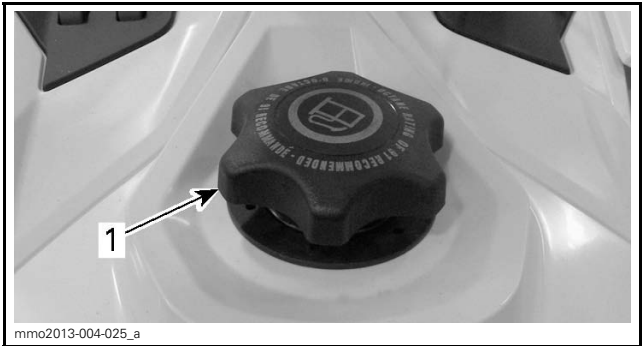

mmo2013-004-025_a

TYPICAL

1. Fuel tank cap

4. Insert the spout into the filler neck.
5. Pour fuel slowly so that air can escape from the tank and prevent fuel flow back. Be careful not to spill fuel.
6. Stop filling when the fuel reaches the bottom of filler neck. Do not overfill.

⚠ WARNING

Never top up the fuel tank before placing the vehicle in a warm area. As temperature increases, fuel expands and may overflow.

7. Fully tighten fuel reservoir cap clockwise.

⚠ WARNING

Always wipe off any small fuel spillage from the vehicle. If a major spillage occurs, remove side panels to remove fuel vapors from engine compartment before starting.

NOTE: Do not sit or lean on seat when fuel tank cap is not properly installed.

BREAK-IN PERIOD

Operation During Break-In

Engine

During the break-in period:

- Avoid prolonged full throttle operation.
- Avoid sustained accelerations.
- Avoid prolonged cruising speeds.
- Avoid engine overheating.

However, brief accelerations and speed variations contribute to a good break-in.

During a predetermined period, the engine management system controls some engine parameters.

The duration is based on fuel volume. It will take approximately two fuel tanks to complete the break-in.

During this period:

- The engine performance and behavior will not be optimal.
- The fuel and oil consumption will be higher.

Also, during the first hours of operation, monitor the level in the water pump shaft oil reservoir. It is normal that it lowers a little. However, it should stabilize after a moment, and then remain stable over time.

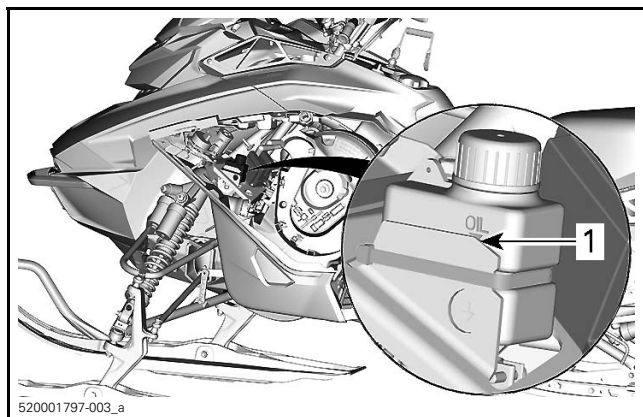

1. Normal oil level

Drive Belt

A new drive belt requires a break in period of 50 km (30 mi).

During the break-in period:

- Avoid strong acceleration and deceleration.
- Avoid pulling a load.
- Avoid high speed cruising.

If the vehicle creeps, lower the drive belt height from the preliminary setting. Refer to *DRIVE BELT* in *MAINTENANCE PROCEDURE*.

BASIC PROCEDURES

Engine Starting Procedure

Procedure

1. Apply parking brake.
2. Recheck throttle control lever operation.
3. Put your helmet on.
4. Ensure that the tether cord cap is installed on the engine cut-off switch and that the cord is attached to your clothing eyelet.
5. Ensure that the emergency engine stop switch is in the ON position.

WARNING

Never depress throttle while starting engine.

6. Release parking brake.

NOTE: For an initial cold start, do not release parking brake. Perform the *VEHICLE WARM-UP* procedure as explained below.

7. Grab rewind starter handle, pull handle slowly until a resistance is felt, then hold handle firmly and pull vigorously to start engine.

NOTE: The maximum torque that can be transmitted to the engine by the rewind starter is 80 N•m (59 lbf•ft). The maximum force that can be exerted on the on the rope is 2 200 N (494.6 lbf).

Vehicle Warm-Up

Before every ride, vehicle has to be warmed up as follows.

1. Start engine as explained in *ENGINE STARTING PROCEDURE* above.
2. Allow engine to warm up one or two minutes at idle speed.

NOTE: Engine will shut down after approximately 5 minutes of idling.

3. Disengage parking brake.
4. Apply throttle until drive pulley engages. Drive at low speed the first two or three minutes.

NOTICE If vehicle does not move when throttle is applied, stop engine, remove tether cord cap from the engine cut-off switch, then do the following.

- Check if skis are stuck on the ground. Lift one ski at a time by the handle, then put it down.
- Check if track is stuck on the ground. Lift rear of snowmobile enough to clear track from the ground, then drop.
- Check rear suspension for hard snow or ice accumulation that could interfere with track rotation. Clean the area.

CAUTION Beware of injuries by using proper lifting techniques, notably by using the force of your legs. Do not attempt to lift the rear of vehicle if it is above your limits.

WARNING

Make sure tether cord cap is removed before standing in front of the vehicle, getting close to the track or rear suspension components.

NOTE: Warm-up is electronically controlled. During this period (up to 10 minutes depending on ambient temperature), engine RPM is limited.

Shutting Off the Engine

Release throttle lever and wait until engine has returned to idle speed.

Shut off the engine using either the emergency engine stop switch or by pulling off the tether cord cap from the engine cut-off switch.

WARNING

Always remove the tether cord cap from engine cut-off switch when vehicle is not in operation in order to prevent accidental engine starting or to avoid unauthorized use by children or others or theft.

RIDING CONDITIONS AND YOUR SNOWMOBILE

Temperature

The engine management of these engines provides the optimum air/fuel ratio for all temperatures.

Hard Packed Snow

This snowmobile's track has a lug profile of 44.5 mm (1.75 in) and BRP **does not recommend** to ride it at **high speed** on a trail, hard packed snow or ice.

In the event that you have to ride on such surfaces, **reduce your speed** and minimize the travel distance.

NOTICE Running that type of track at high speeds on a trail, on hard packed surfaces or ice puts more stress on the lugs, causing heat. To avoid potential premature degradation or damage to the track, reduce your speed, and minimize the distance you ride on those surfaces.

SPECIAL OPERATION

Towing Another Snowmobile

If a snowmobile is disabled and must be towed use a rigid tow bar. Remove the drive belt from disabled snowmobile, refer to *DRIVE BELT* in *MAINTENANCE PROCEDURES* and tow at moderate speed.

NOTICE Always remove the drive belt of the snowmobile that is to be towed to prevent damage to its belt and drive system.

In an emergency situation only, if a rigid tow bar is not available, a rope can be used. Proceed with extra caution. In some areas, it may be illegal to do so. Check with state or local authorities.

Remove the drive belt, attach the rope to the ski legs (spindles), have someone sit on the towed snowmobile to activate the brake, and tow at low speed.

NOTICE In order to prevent damage to the steering system, never attach the tow rope to the ski handles.

WARNING

Never ride at high speed when towing a disabled snowmobile. Proceed slowly with extra caution.

TUNE YOUR RIDE

Snowmobile handling and comfort depend upon multiple adjustments.

WARNING

Suspension adjustment could affect vehicle handling. Always take time to familiarize yourself with the vehicle's behavior after any suspension adjustment have been made. Always adjust LH and RH suspension components to the same setting.

Choice of suspension adjustments vary with carrying load, operator's weight, personal preference, riding speed and field condition.

NOTE: Some adjustments may not apply to your snowmobile.

WARNING

Before proceeding with any suspension adjustment, remember:

- Park in a safe place.
- Remove the tether cord cap from the engine cut-off switch.
- Use appropriate lifting device or have assistance to share lifting stress. If a lifting device is not used, use proper lifting techniques, notably by using the force of your legs.
- Do not attempt to lift the front or rear of vehicle if it is above your limits.
- Support front of vehicle off the ground with a suitable device before adjusting suspension.
- Support rear of vehicle off the ground with a wide-base snowmobile stand with a rear deflector panel.
- Make sure support device is stable and secure.

The best way to set up the suspension is to customize each adjustment one at a time. Various adjustments are interrelated. It may be necessary to readjust center spring after adjusting front springs for instance. Test run the snowmobile under the same conditions; trail, speed, snow, operator riding position, etc. Proceed methodically until you are satisfied.

Following are guidelines to fine-tune suspension. Use suspension adjustment tool provided in the tool kit.

Rear Suspension Adjustments

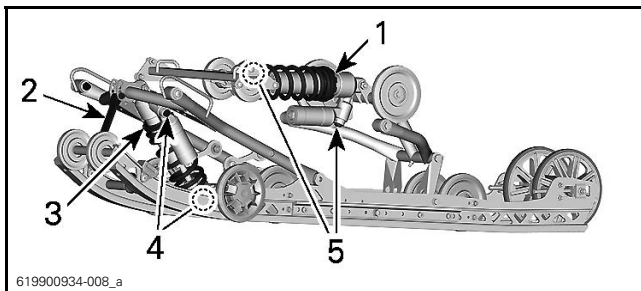

TYPICAL - ADJUSTABLE COMPONENTS

1. Rear spring
2. Stopper strap
3. Center spring
4. Center shock absorber
5. Rear shock absorber

NOTICE Whenever adjusting rear suspension, check track tension and adjust if necessary.

Stopper Strap

Stopper strap length has an effect on the amount of weight the center spring has to carry especially during acceleration, therefore on the front end uplift.

Stopper strap length also has an effect on center spring travel.

NOTICE Whenever stopper strap length is changed, track tension must be checked.

NOTE: Stopper strap can be set to position 1, 2, 3 or 4. Smaller numbers correspond to a longer strap setting.

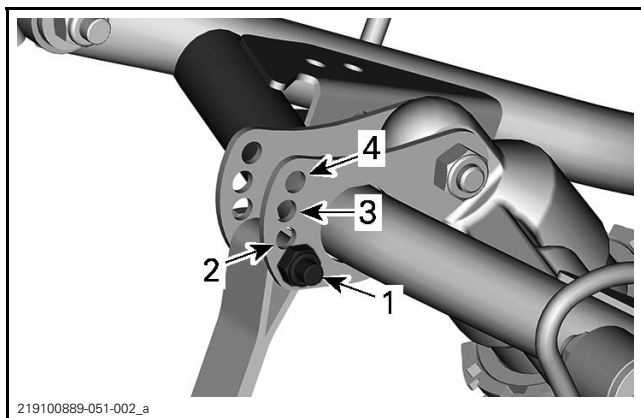

219100889-051-002_a

STOPPER STRAP POSITIONS

1. Position 1 (longest)
2. Position 2
3. Position 3
4. Position 4 (shortest)

When operating the snowmobile in deep snow or hill climbing, it may be necessary to vary stopper strap length and/or riding position, to change the angle at which the track rides on the snow. Operator's familiarity with the various adjustments as well as snow conditions will dictate the most efficient combination.

Generally, a longer stopper strap setting gives better performance on a flat landscape and a shorter setting will improve handling in steep hill climbing and deep snow conditions.

STOPPER STRAP SETTING	
POSITION	USE
1	Best setting for big humps and low speed corners
2	Normal setting: Best overall setting (General use)
3	Best setting for medium sized humps and fast corners
4	Best setting for small humps and fast corners

Center Spring

Center spring preload has an effect on steering effort, handling and bump absorption.

Also, since center spring preload adjustment puts more or less pressure on the front of the track, it has an effect on the performance in deep snow.

ACTION	RESULT
Increasing preload	Lighter steering
	More bump absorption capability
Decreasing preload	Heavier steering
	Less bump absorption capability

To adjust, unscrew the locking ring, then turn the adjustment ring to set the spring preload.

When the desired preload is set, tighten the locking ring against the adjustment ring.

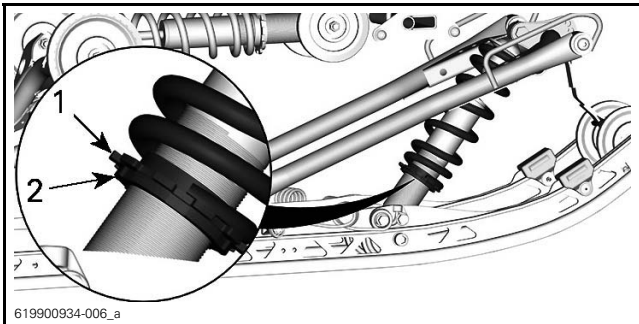

1. Adjustment ring
2. Locking ring

Rear Spring

Rear spring preload has an effect on comfort, ride height and load compensation.

Also, adjusting rear spring preload shifts more or less weight to the snowmobile front end. As a result, more or less weight is applied to the skis. This has an effect on performance in humps and corners, steering effort and handling.

Slight suspension bottoming occurring under the worst riding conditions indicates a good choice of spring preload.

ACTION	RESULT
Increasing preload	Firmer rear suspension
	Higher rear end
	More bump absorption capability
	Heavier steering
Decreasing preload	Softer rear suspension
	Lower rear end
	Less bump absorption capability
	Lighter steering
	More ski lift when accelerating or starting

To adjust, unscrew the locking ring, then turn the adjustment ring to set the spring preload.

When the desired preload is set, tighten the locking ring against the adjustment ring.

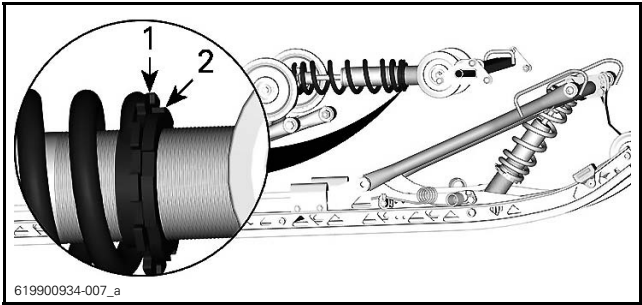

619900934-007_a

1. Adjustment ring
2. Locking ring

Center and Rear Shock Absorber Adjustments

Compression Damping

Low speed compression damping controls how the shock absorber reacts to a low suspension velocity (slow compression strokes, in most cases when riding at lower speeds).

High speed compression damping controls how the shock absorber reacts to a high suspension velocity (quick compression strokes, in most cases when riding at higher speeds).

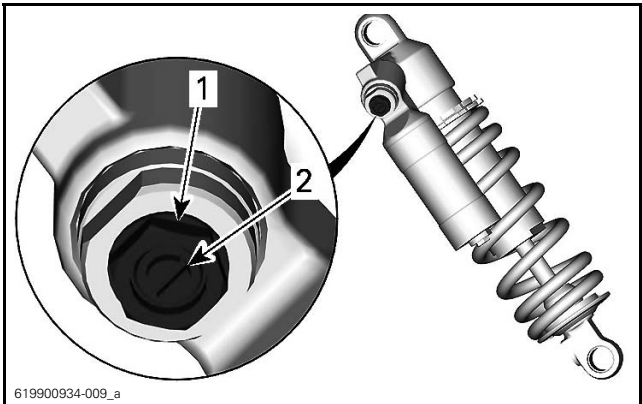

619900934-009_a

1. High speed compression adjuster (hexagonal)
2. Low speed compression adjuster (slotted)

TURNING	ACTION	RESULT ON BIG AND SMALL BUMPS
Clockwise	Increasing compression damping force	Firmer compression damping
Counter Clockwise	Decreasing compression damping force	Softer compression damping

Rebound Damping

Rebound damping controls how the shock absorber restrains the extension stroke.

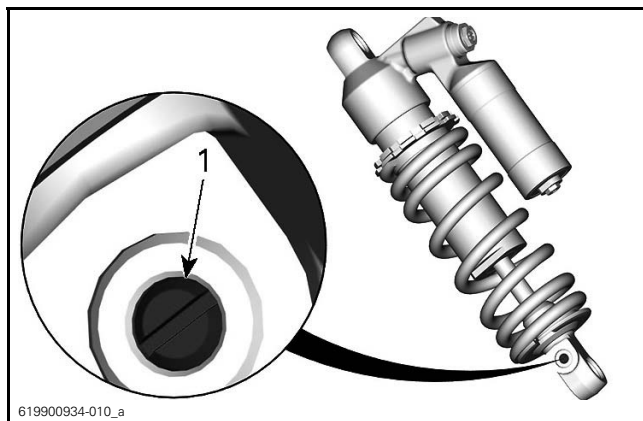

619900934-010_a

1. Rebound adjuster

TURNING	ACTION	RESULT ON BIG AND SMALL BUMPS
Clockwise	Increasing rebound damping force	Firmer rebound damping (slower extension speed)
Counter Clockwise	Decreasing rebound damping force	Softer rebound damping (faster extension speed)

NOTE: In repetitive short small bumps (ripple), it is recommended to use a lower rebound damping setting.

Front Suspension Adjustments

Front Springs

Front spring preload has an effect on front suspension firmness.

Front spring preload also has an effect on the steering behavior.

ACTION	RESULT
Increasing preload	Firmer front suspension
	Higher front end
	More precise steering
	More bump absorption capability
Decreasing preload	Softer front suspension
	Lower front end
	Lighter steering
	Less bump absorption capability

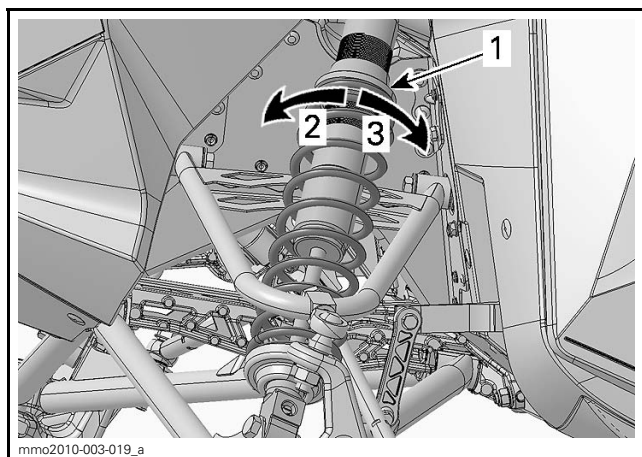

TYPICAL

1. Spring preload adjustment ring
2. Increase preload
3. Decrease preload

NOTICE Make sure that both front springs are still pre-loaded when front of vehicle is off the ground.

Shock Absorber Damping

Low Speed Compression Damping

Low speed compression damping controls how the shock absorber reacts to a low suspension velocity (slow compression strokes, in most cases when riding at lower speeds).

ACTION	RESULT
Increasing low speed compression damping force	Firmer compression damping (slow compression)
Decreasing low speed compression damping force	Softer compression damping (slow compression)

To adjust, turn clockwise to increase damping force and counter-clockwise to decrease damping force.

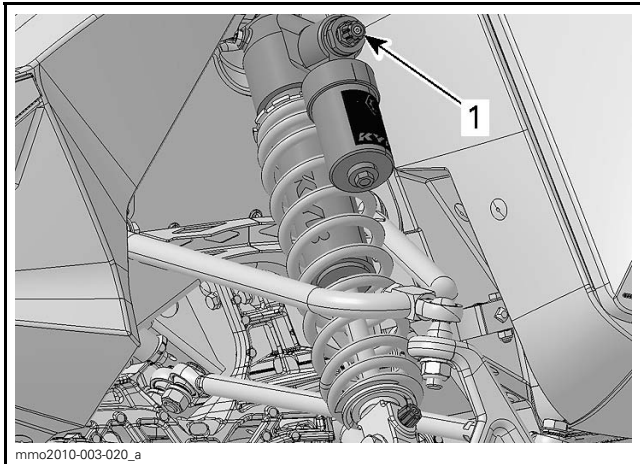

1. Low speed compression damping adjuster (slot or knob)

High Speed Compression Damping

High speed compression damping controls how the shock absorber reacts to a high suspension velocity (quick compression strokes, in most cases when riding at higher speeds).

ACTION	RESULT
Increasing high speed compression damping force	Firmer compression damping (fast compression)
Decreasing high speed compression damping force	Softer compression damping (fast compression)

To adjust, turn clockwise to increase damping force and counter-clockwise to decrease damping force.

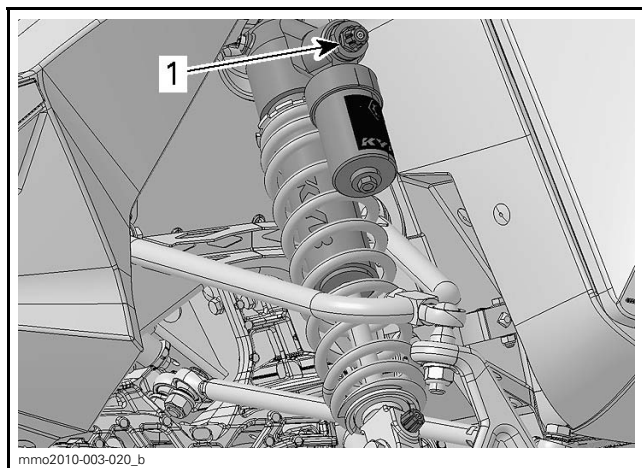

1. High speed compression damping adjuster (hexagonal)

Rebound Damping

Rebound damping controls how the shock absorber restrains the extension stroke.

ACTION	RESULT
Increasing rebound damping force	Firmer rebound damping (extension stroke)
Decreasing rebound damping force	Softer rebound damping (extension stroke)

NOTE: In repetitive short small bumps (ripple), it is recommended to use a lower rebound damping setting.

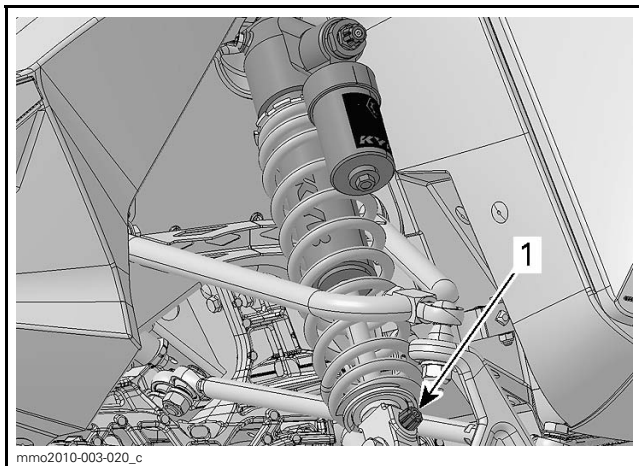

1. Rebound adjuster (knob or slot)

Adjustment Tips According to Vehicle Behavior

PROBLEM	CORRECTIVE MEASURES
Front suspension darting	Check ski alignment. – Reduce front suspension spring preload. – Increase center spring preload. – Reduce rear spring preload.
Steering feels too heavy at steady speeds	– Reduce front suspension spring preload. – Increase center spring preload.
Steering feels too heavy during acceleration	– Set coupling blocks to a lower position. – Reduce rear spring preload. – Lengthen limiter strap.
Too much ski lift during cornering or acceleration	– Shorten limiter strap. – Increase rear spring preload.

TUNE YOUR RIDE

PROBLEM	CORRECTIVE MEASURES
Rear of snowmobile seems too stiff	<ul style="list-style-type: none">- Reduce rear spring preload.- Reduce compression damping adjustment if equipped
Rear of snowmobile seems too soft	<ul style="list-style-type: none">- Increase rear spring preload.
Rear suspension is frequently bottoming	<ul style="list-style-type: none">- Increase compression damping adjustment if equipped.- Increase rear spring preload.- Increase center spring preload.- Lengthen limiter strap.- Increase compression damping adjustment if equipped.
Snowmobile seems to pivot around its center	<ul style="list-style-type: none">- Reduce center spring preload.- Increase rear spring preload.- Increase front suspension spring preload.- Shorten limiter strap.

REAR AND FRONT SUSPENSION SPRING PRELOAD FACTORY SETTINGS

MODEL	SKI	FRONT ARM	REAR ARM
600 RS	8 mm	10 mm	18 mm

CLICKER FACTORY SETTINGS						
MODEL	SKI SHOCK		CENTER SHOCK		REAR SHOCK	
600 RS	505074871 / 505074870		503195765		503195767	
	Low Speed	12 Clicks open	Low Speed	10 Clicks open	Low Speed	10 Clicks open
	High Speed	1,5 Turns open	High Speed	1,5 Turns open	High Speed	1,5 Turns open
	Rebound	6 Clicks open	Rebound	6 Clicks open	Rebound	6 Clicks open

VEHICLE TRANSPORTATION

Make sure that oil reservoir and fuel tank caps are properly installed.

Tilt bed trailers can easily be equipped with a winch mechanism to afford maximum safety in loading. Simple as it may seem, never drive your snowmobile onto a tilt bed trailer or any other kind of trailer or vehicle. Many serious accidents have resulted from driving up and over a trailer. Anchor your vehicle securely, front and rear, even on short hauls. Be certain all equipment is securely fastened. Cover your snowmobile when trailering to prevent road grime from causing damage.

Be certain your trailer meets state or provincial requirements. Ensure the hitch and safety chains are secure and the brake, turn indicators and clearance lights all function.

WARNING

Do not tow the vehicle facing backwards. If the vehicle is towed facing backwards, the wind may cause damage to the windshield or even loss of the windshield.

MAINTENANCE

MAINTENANCE SCHEDULE

Maintenance is very important for keeping your vehicle in safe operating condition. A repair shop or person of the owner's choosing may maintain, replace, or repair emission control devices and systems. These instructions do not require components or service by BRP or authorized Lynx dealers. Proper maintenance is the owner's responsibility. A warranty claim may be denied if, among other things, the owner or operator caused the problem through improper maintenance or use. You must follow the instructions for fuel requirements in *FUEL*. Even if gasoline containing greater than ten volume percent ethanol is readily available, the US EPA issued a prohibition against the use of gasoline containing greater than 10 vol% ethanol that applies to this vehicle. The use of gasoline containing greater than 10 vol% ethanol with this engine may harm the emission control system. The vehicle should be serviced as per the maintenance schedule.

The maintenance schedule does not exempt the pre-ride inspection.

WARNING

Failure to properly maintain the vehicle according to the maintenance schedule and procedures can make it unsafe to operate.

EVERY YEAR AT PRESEASON OR 3 000 KM (2,000 MI) (WHICHEVER COMES FIRST)

Perform pre-ride inspection

Check fault codes

Adjust drive chain

Adjust and align track

Inspect brake hose, pads and disk

Check coolant density

Inspect drive belt

Visually inspect and clean drive pulley

Inspect and clean driven pulley

Lubricate rear suspension. Lubricate whenever the vehicle is used in wet conditions (rain, puddles)

**EVERY YEAR AT PRESEASON OR 3 000 KM (2,000 MI)
(WHICHEVER COMES FIRST)**

Inspect exhaust system and check for leaks

Tighten exhaust manifold screws to specified torque

Inspect fuel lines, oil lines and connections

Inspect front suspension

Inspect rear suspension (including stopper straps and slider shoes)

Inspect tie-rod ends and ski alignment

Inspect engine rubber mounts

Lubricate front suspension shocks upper spherical bearings

**EVERY 2 YEARS OR 6 000 KM (4,000 MI) (WHICHEVER
COMES FIRST)**

Replace brake fluid

Inspect throttle cable

Clean and lubricate rewind starter

Replace chaincase oil

**EVERY 3 YEARS OR 10 000 KM (6,000 MI) (WHICHEVER
COMES FIRST)**

Replace spark plugs

Clean RAVE valves

EVERY 5 YEARS

Replace engine coolant

Replace in-line fuel filter

MAINTENANCE PROCEDURES

This section includes instructions for basic maintenance procedures.

WARNING

Turn off the engine, remove tether cord cap and follow these maintenance procedures when performing maintenance. If you do not follow proper maintenance procedures you can be injured by hot parts, moving parts, electricity, chemicals or other hazards.

WARNING

Should removal of a locking device be required (e.g. lock tabs, self-locking fasteners, etc.) when undergoing disassembly/assembly, always replace with a new one.

Engine Coolant

WARNING

Never open coolant tank cap when engine is hot.

Engine Coolant level Verification

Open the RH side panel, see *CONTROLS, INSTRUMENTS AND EQUIPMENT*.

Check coolant level at room temperature with the cap removed. Liquid should be at cold level line of coolant tank.

NOTE: When checking level at low temperature it may be slightly lower than the mark.

If additional coolant is necessary or if entire system has to be refilled, refer to an authorized Lynx dealer, repair shop or person of your own choosing.

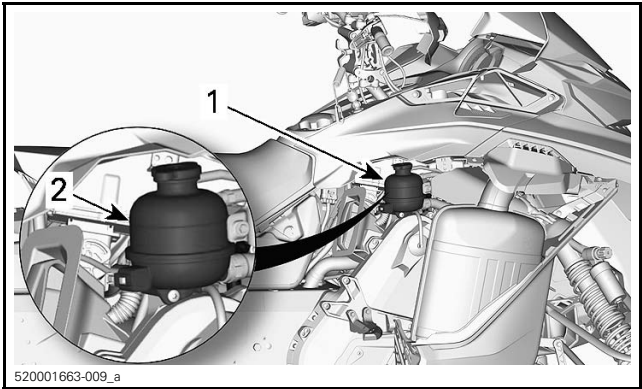

TYPICAL

- 1. Coolant reservoir
- 2. COLD line

Recommended Engine Coolant

COUNTRY	RECOMMENDED COOLANT
Scandinavia	EXTENDED LIFE PRE-MIXED COOLANT (EUR) (P/N 779223)
All other countries	EXTENDED LIFE PRE-MIXED COOLANT (P/N 779150)
Alternative, or if not available	Distilled water and antifreeze solution (50% distilled water, 50% antifreeze)

NOTICE A blend of 50% antifreeze with 50% distilled water will improve the cooling efficiency. Using water tap instead of distilled water, would contribute to make deposits in cooling system and to reduce antifreeze efficiency. This could lead to engine overheating.

To prevent antifreeze deterioration, always use the same brand. Never mix different brands unless cooling system is completely flushed and refilled.

NOTICE To prevent rust formation or freezing condition in cold areas, always replenish the system with 50% antifreeze and 50% distilled water. Pure antifreeze will freeze at a higher temperature than the optimal water/antifreeze mix. Always use ethylene glycol antifreeze containing corrosion inhibitors specifically recommended for aluminum engines.

Exhaust System

Exhaust System Verification

The muffler tail pipe should be centered with the exit hole in the bottom pan. Exhaust system must be free of rust or leaks. Make sure that all parts are securely in place.

Check retaining springs condition and replace if necessary.

The exhaust system is designed to reduce noise and to improve the total performance of the engine. Modification may be in violation of local laws.

NOTICE If any exhaust system component is removed, modified or damaged, severe engine damage may result.

Spark Plugs Replacement

Removing the Spark Plugs

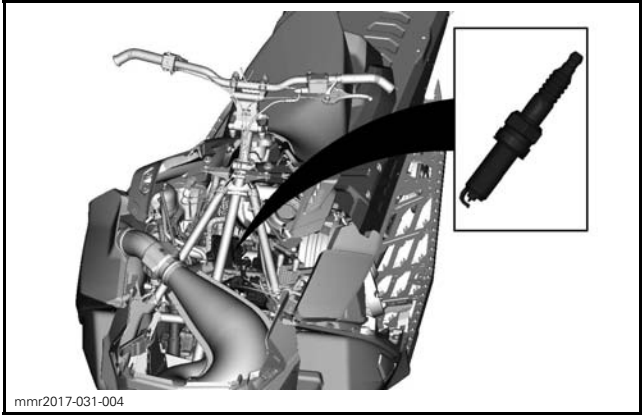

1. Disconnect the stator connector. Refer to *STATOR CONNECTOR ACCESS* in the *MAGNETO AND STARTER* subsection of the shop manual.
2. Remove the upper body module. For procedure, refer to *BODY* subsection of the shop manual.
3. Remove cover, refer to *TOP END* subsection of the shop manual.
4. Clean the spark plug and cylinder head with pressurized air.

WARNING

Whenever using compressed air, always wear protective eye wear.

5. Remove lock securing spark plug wire to spark plug.

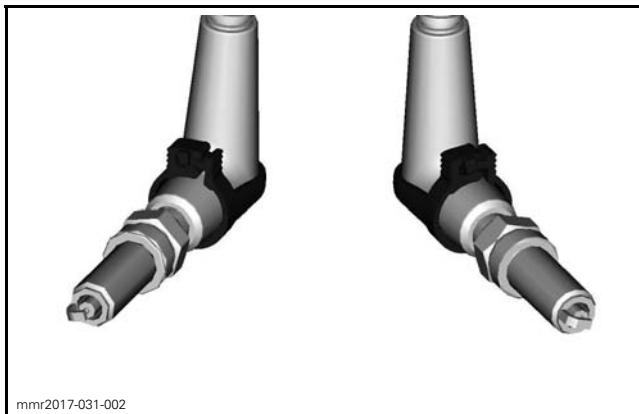

6. Remove spark plug cables as shown.

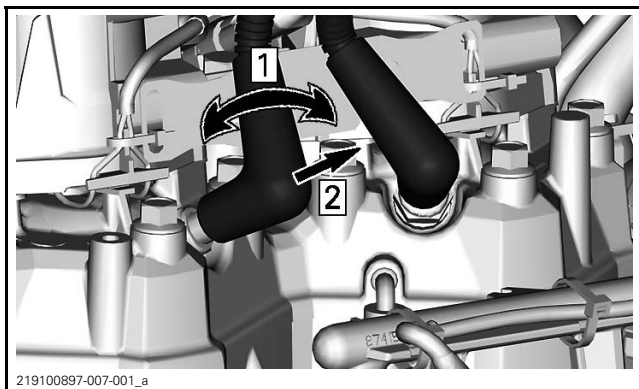

- Step 1: Gently rotate*
Step 2: Pull off

7. Unscrew the spark plug sufficiently to break the applied torque using the appropriate tools.



8. Remove spark plugs by hand.

Installing the Spark Plugs (OEM)

1. Prior to installation, ensure the contact surfaces of the cylinder head and spark plug are free of grime.
2. Using a wire gauge, confirm electrode gap is as specified. Refer to *TECHNICAL SPECIFICATIONS*.

NOTE: If spark plug gap is incorrect, use another spark plug.

3. Hand screw spark plug into cylinder head until it bottoms out.
4. Apply specific torque using a torque wrench and approved spark plug socket.

NOTE: Spark plug tightening torque is particularly important on this engine as it contributes to the proper positioning of the negative electrode.

TIGHTENING TORQUE	
Spark plug	$18 \text{ N}\cdot\text{m} \pm 0.7 \text{ N}\cdot\text{m}$ $(159 \text{ lbf}\cdot\text{in} \pm 6 \text{ lbf}\cdot\text{in})$

Installing the Spark Plugs (Non-OEM)

NOTE: When using a non-OEM spark plug, it must be correctly indexed or engine may experience rough idling and higher emissions.

1. Using a marker, mark the open end of the negative electrode on the plug shell (above threads).
2. Ensure the contact surfaces of the cylinder head and spark plug are free of grime.
3. Install and torque the spark plug, refer to previous table for specific torque.
4. Visually check to ensure the open end of the negative electrode is facing the injector nozzle within 90° each side of nozzle.

NOTE: The following illustration uses the point of attachment of the negative electrode to depict the angle. The injector is illustrated above the spark plug.

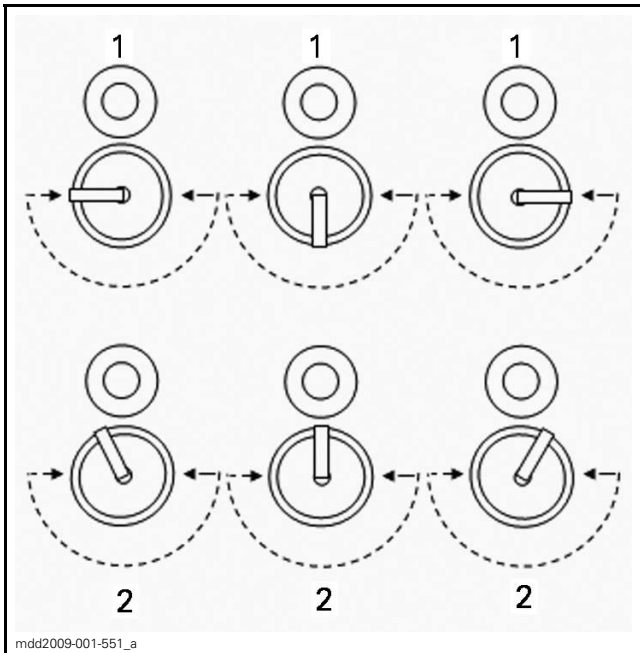
**SPARK PLUG INDEXING**

1. *Acceptable installation*
2. *Unacceptable installation*

If the plug indexing angle is not within specification, repeat procedure with another spark plug until correct indexing is achieved.

Brake Fluid**Recommended Fluid**

Use only DOT 4 brake fluid from a sealed container. An opened container may be contaminated or may have absorbed moisture from the air.

! WARNING

Use only DOT 4 brake fluid from a sealed container. To avoid serious damage to the braking system, do not use fluids other than the recommended one, nor mix different fluids for topping up.

NOTICE Brake fluid can damage painted and plastic parts. Handle with care. Rinse thoroughly in case of spillage.

Brake Fluid Level Verification

NOTICE Vehicle must be on a level surface before checking any fluid levels.

Check brake fluid (DOT 4) in reservoir for proper level. Add fluid (DOT 4) as required.

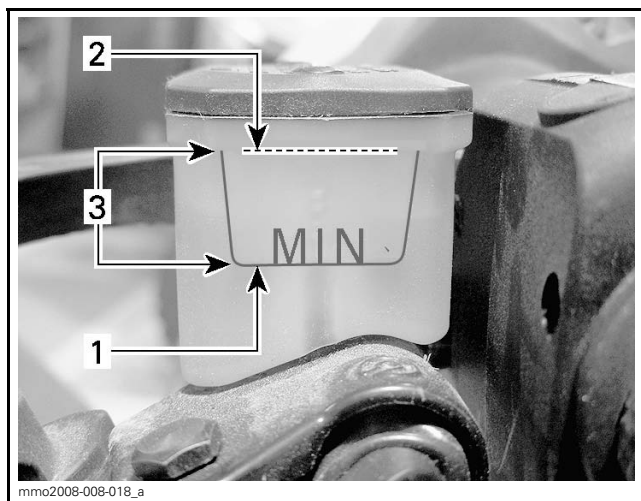

TYPICAL

1. Minimum
2. Maximum
3. Operating range

⚠ CAUTION Avoid getting brake fluid on skin or eyes - it may cause severe burns. In case of contact skin, wash thoroughly. In case of contact with the eyes, immediately rinse with plenty of water for at least 10 minutes and then consult a doctor immediately.

Chaincase Oil

Recommended Chaincase Oil

RECOMMENDED CHAINCASE OIL	
Scandinavia	SYNTHETIC CHAINCASE OIL (EUR) (P/N 779185)
All other countries	SYNTHETIC CHAINCASE OIL (P/N 779156)

NOTICE The chaincase of this snowmobile has been developed and validated using the XPS™ Synthetic chaincase oil. BRP strongly recommends the use of its XPS Synthetic chaincase oil at all times. Damages caused by oil which is not suitable for the chaincase will not be covered by the BRP limited warranty.

Access to Chaincase

Open RH side panel, refer to *CONTROLS, INSTRUMENTS AND EQUIPMENT*.

Chaincase Oil Level Verification

With the vehicle on a level surface, check the oil level by removing the check plug.

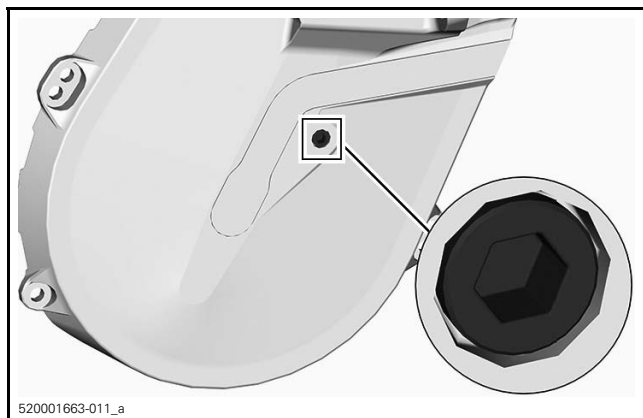

520001663-011_a
CHECK PLUG

Oil level must reach the threaded hole.

If level is correct, reinstall check plug and tighten to the specified torque.

TIGHTENING TORQUE	
Check plug	$6 \text{ N}\cdot\text{m} \pm 1 \text{ N}\cdot\text{m}$ ($53 \text{ lbf}\cdot\text{in} \pm 9 \text{ lbf}\cdot\text{in}$)

If level is insufficient, See *CHAINCASE FILLING PROCEDURE*.

Chaincase Filling Procedure

Remove the check plug.

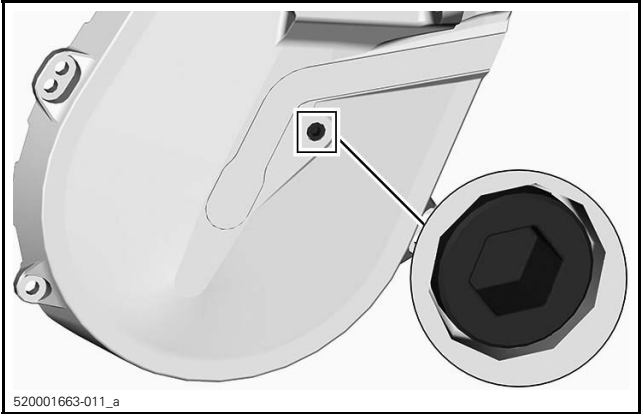

CHECK PLUG

Remove the filler cap.

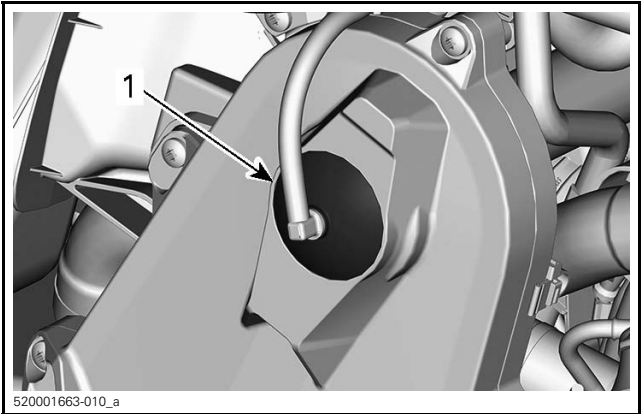

TYPICAL - TOP OF CHAINCASE

1. Filler cap

Pour recommended oil in the filler hole until oil comes out by the check plug hole.

Reinstall check plug and tighten to the specified torque.

TIGHTENING TORQUE	
Check plug	$6 \text{ N}\cdot\text{m} \pm 1 \text{ N}\cdot\text{m}$ ($53 \text{ lbf}\cdot\text{in} \pm 9 \text{ lbf}\cdot\text{in}$)

Reinstall the filler cap.

Drive Chain

Access to Chaincase

Open RH side panel, refer to *CONTROLS, INSTRUMENTS AND EQUIPMENT*.

Drive Chain Adjustment

Using the Torx end of the driven pulley expander, GENTLY turn tensioner clockwise to eliminate the play.

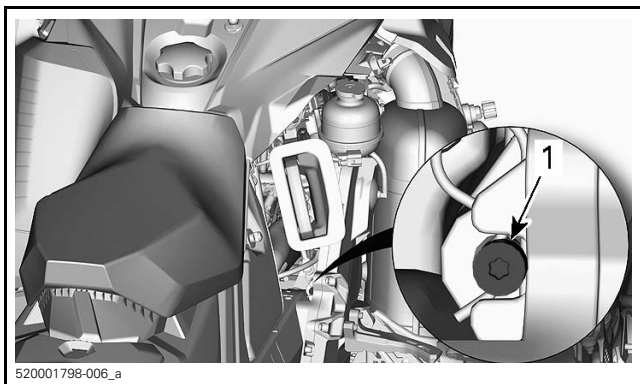

TYPICAL

Do not force the tensioner in.

NOTE: Do not remove the hair cotter pin.

NOTICE Overtightening the drive chain could result in severe damage to the chaincase components.

Drive Belt

Drive Belt Inspection

Inspect belt for cracks, fraying or abnormal wear (uneven wear, wear on one side, missing cogs, cracked fabric). If abnormal wear is noted, probable cause could be pulley misalignment, excessive RPM with frozen track, fast starts without warm-up period, burred or rusty sheave, oil on belt or distorted spare belt. Contact an authorized Lynx dealer.

Drive Belt Replacement

Drive Belt Removal

1. Remove tether cord cap from engine cut-off switch.
2. Remove drive belt guard, refer to *CONTROLS, INSTRUMENTS AND EQUIPMENT*.
3. Insert the driven pulley expander provided in the threaded hole on the adjuster hub as shown.



A33D1AA

4. Open the driven pulley by screwing the tool in.
5. Remove the drive belt by slipping it over the top of the driven pulley, then over the drive pulley.

Drive Belt Installation

1. If necessary, open the driven pulley, refer to *DRIVE BELT REMOVAL* above.
2. Slip the belt over the drive pulley, then over the driven pulley.

NOTICE Do not force or use tools to pry the belt into place, as this could cut or break the cords in the belt.

NOTE: The maximum drive belt life span is obtained when belt is installed with arrows in the direction of rotation.

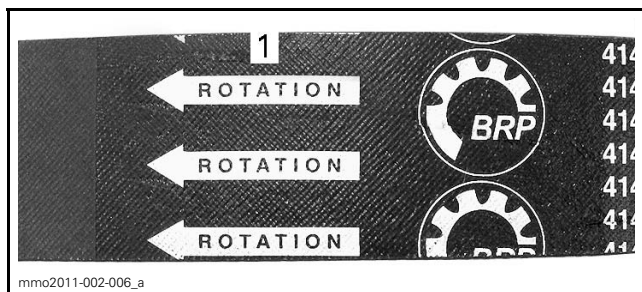

1. To be pointed in the direction of rotation
3. Unscrew and remove the driven pulley expander from the pulley.
4. Rotate the driven pulley several times to properly set the belt between the sheaves.
5. If a new belt was installed, an adjustment will be required for the proper belt height. Refer to *DRIVE BELT ADJUSTMENT* below.
6. Install belt guard, refer to *CONTROLS, INSTRUMENTS AND EQUIPMENT*.
7. Close side panel, refer to *CONTROLS, INSTRUMENTS AND EQUIPMENT*.

Drive Belt Adjustment

Drive belt adjustment must be performed every time a new belt is installed and as part of the pre-ride inspection.

To adjust the drive belt, proceed as follows:

1. Remove the tether cord cap.

2. Open LH side panel, refer to *CONTROLS, INSTRUMENTS AND EQUIPMENT*.
3. Remove belt guard, refer to *DRIVE BELT GUARD REMOVAL*.
4. Keep the set screw from turning using a 1/8 inch Allen wrench and loosen the lock nut using a 7/16 in open wrench.
5. Turn the set screw 1/4 turn at a time then rotate the driven pulley to properly set the belt between the pulley sheaves. Measure belt deflection using a straight edge and the tensiometer as explained below.

REQUIRED TOOL	
TENSIOMETER (P/N 414 348 200)	

6. Repeat until the right belt deflection is reached.

NOTE: Turn the set screw clockwise to increase the distance between the sheaves and counterclockwise to decrease the distance.

7. Tighten the lock nut after the belt adjustment has been made.

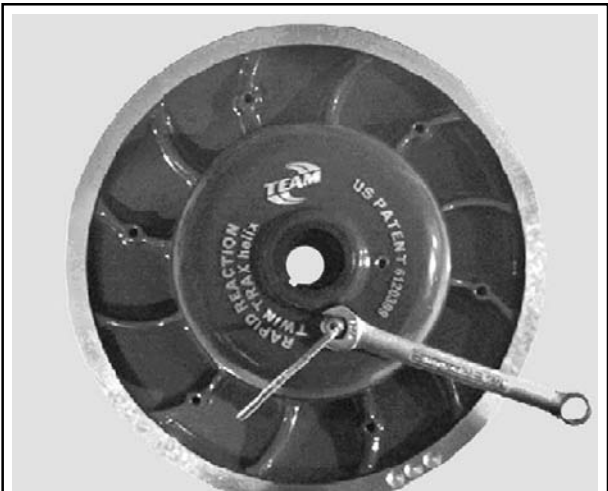

A32D34A

Belt Deflection Measurement

1. Set deflection between 27 mm (1.06 in) and 37 mm (1.46 in) using bottom O-ring.



DEFLECTION SETTING

1. Bottom O-ring set to specification
2. Place upper O-ring to 0 kgf (0 lbf).
3. Position a straight edge ruler on the drive belt.
4. Position the tensiometer on drive belt, halfway between pulleys.
5. Push the tensiometer downwards until bottom O-ring (deflection) be aligned with the inner edge of the straight ruler.
6. Read load recorded by the upper O-ring on the tensiometer.



LOAD READING

1. Upper O-ring
7. Load reading must be as per the following table.

DRIVE BELT ADJUSTMENT SPECIFICATION	
Belt deflection setting	27 mm to 37 mm (1.06 in to 1.46 in)
Belt load reading	11.3 kg (25 lb)

8. Adjust as required.

Drive Pulley

Drive Pulley Adjustment

WARNING

Remove tether cord cap from engine cut-off switch before performing any adjustment. Vehicle must be parked in a safe place, away from the trail.

WARNING

NEVER disassemble or modify the drive pulley. Improper assembly or modifications could cause the pulley to explode violently under the stress generated by the high rotational speed. See your Lynx dealer to maintain or service the drive pulley. Improper servicing or maintenance may affect performance and reduce belt life. Always respect maintenance schedules.

The drive pulley is factory calibrated to transmit maximum engine power at a predefined RPM. Factors such as ambient temperature, altitude or surface condition may vary this critical engine RPM thus affecting snowmobile efficiency.

This adjustable drive pulley allows setting maximum engine RPM to maintain maximum power.

Ramp cams should be adjusted so that actual maximum engine RPM matches the maximum horsepower RPM. Refer to *SPECIFICATIONS (ENGINE)*.

NOTE: Use a precision digital tachometer for engine RPM adjustment.

There are 5 positions in which the ramp cam can be set.

Each position modifies the maximum engine RPM by about 200 RPM.

Lower position numbers decrease engine RPM in steps of 200 RPM and higher position numbers increase it in steps of 200 RPM.

Procedure

1. Refer to *CONTROLS, INSTRUMENTS AND EQUIPMENT* and remove:
 - LH side panel
 - Drive pulley guard
2. Locate the cam and the pivot screw on the drive pulley.

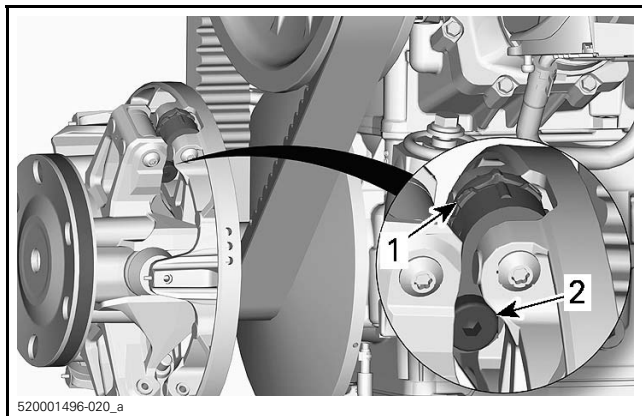

TYPICAL

1. Cam
2. Pivot screw

The cam position is identified as follows:

- Positions 1, 2, 4 and 5 are numbered.
- Position 3 (middle) is identified by a notch.
- There are notches on each side of the cam used as pointers.

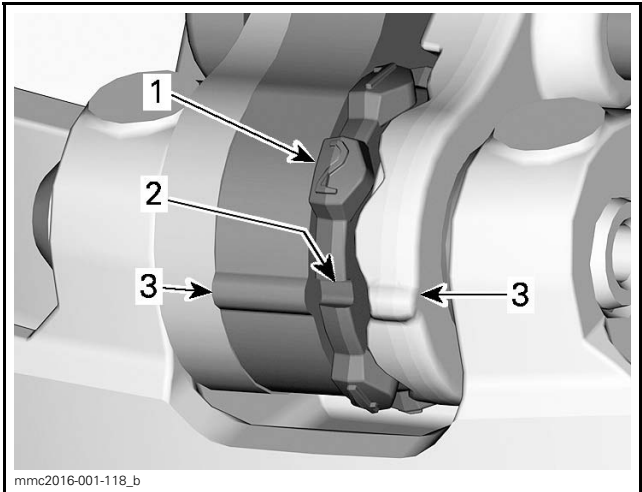

1. *Numbered position*
2. *Position 3 - Notch*
3. *Pointers*

To adjust, proceed as follows for all 3 cams:

3. Using the driven pulley expander, loosen the pivot screw.

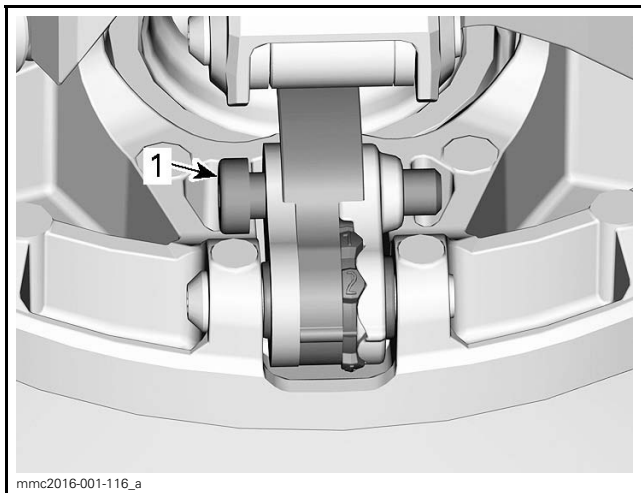

1. *Pivot screw*

4. Move the right lever aside to be able to turn the cam.
5. Turn cam to the desired position.

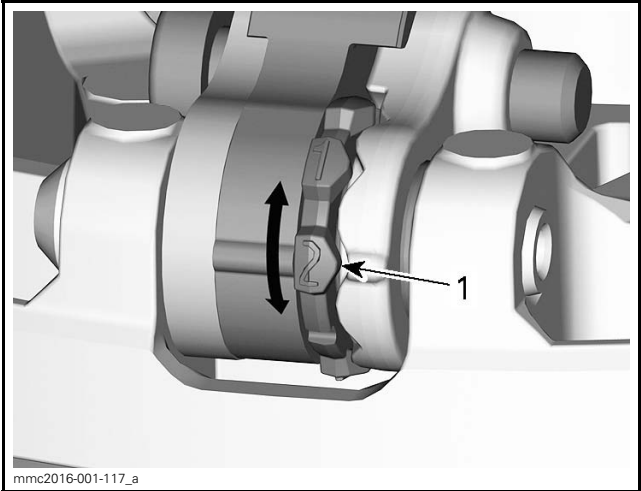

1. Desired cam position (here #2)

6. Tighten the pivot screw.

TIGHTENING TORQUE	
Pivot	5 N•m ± 1 N•m (44 lbf•in ± 18 lbf•in)

NOTICE Always adjust all 3 cams to the same setting.

Track

Track Condition

WARNING

Remove tether cord cap from engine cut-off switch before performing any maintenance or adjustment, unless otherwise specified. Vehicle must be parked in a safe place, away from the trail.

Remove tether cord cap from engine cut-off switch.

Lift the rear of the snowmobile and support it with a wide-base snowmobile mechanical stand with a rear deflector panel. With the engine off, rotate the track by hand, and inspect condition. If worn or cut, or if track fibers are exposed, or if missing or defective inserts or guides are noted; contact an authorized Lynx dealer.

Snowmobiles Equipped with Traction Enhancing Products

If your snowmobile is equipped with a BRP approved studded track, **PROCEED WITH A VISUAL INSPECTION OF YOUR TRACK BEFORE EACH USE.**

Look for any defects, such as:

- Perforations in the track
- Tears in the track (particularly around traction holes on studded tracks)
- Lugs that are broken or torn off, exposing portions of rods
- Delamination of the rubber
- Broken rods
- Broken studs (studded tracks)
- Bent studs (studded tracks)
- Missing studs
- Studs that are torn off the track
- Missing track guide(s)
- Also, ensure that studs nut are tighten to the recommended torque.

On approved studded tracks, replace broken or damaged studs immediately. If your track shows signs of deterioration, it must be replaced immediately. When in doubt, ask your dealer.

WARNING

Riding with a damaged track or studs could lead to a loss of control.

For complete information on traction enhancing products, refer to *TRACTION ENHANCING PRODUCTS* in *SAFETY INFORMATION* at the beginning of this Operator's Guide.

Track Tension and Alignment

NOTE: Track tension and alignment are interrelated. Do not adjust one without the other.

⚠ WARNING

To prevent serious injury to individuals near the snowmobile:

- NEVER stand behind or near a moving track.
- Always use a wide-base snowmobile stand with a rear deflector panel if it is necessary to rotate track.
- When the track is raised off the ground, only run it at the lowest possible speed.

Centrifugal force could cause debris, damaged or loose studs, pieces of torn track, or an entire severed track to be violently thrown backwards out of the tunnel with tremendous force, possibly resulting in the loss of a leg or other serious injury.

Track Tension Verification

NOTE: Ride the snowmobile in snow about 15 to 20 minutes prior to adjusting track tension.

1. Remove tether cord cap from engine cut-off switch.
2. Lift rear of vehicle and support it off the ground.

⚠ CAUTION Use proper lifting techniques, notably by using the force of your legs. Do not attempt to lift the rear of vehicle if it is above your limits.

3. Allow rear suspension to fully extend.
4. Use the tensiometer.

REQUIRED TOOL	
<p>TENSIOMETER (P/N 414 348 200)</p>	

5. Set deflection between 30 mm and 35 mm (1-3/16 in and 1-3/8 in) using bottom O-ring.

MAINTENANCE PROCEDURES



DEFLECTION SETTING

1. Bottom O-ring set to specification

6. Place upper O-ring to 0 kgf (0 lbf).
7. Position the tensiometer on track, halfway between front and rear idler wheels.
8. Push the tensiometer downwards until bottom O-ring (deflection set earlier) be aligned with the bottom of slider shoe.

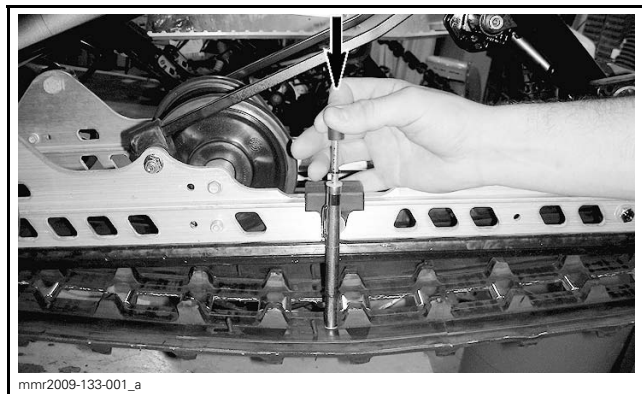

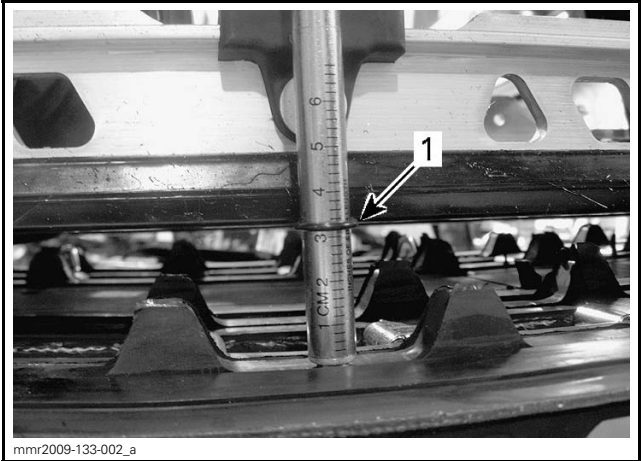

mmr2009-133-002_a

1. Deflection O-ring aligned with slider shoe

9. Read load recorded by the upper O-ring on the tensiometer.



mmr2009-133-003_a

LOAD READING

1. Upper O-ring

10. Load reading must be as per the following table.

TRACK ADJUSTMENT SPECIFICATION	
Track deflection setting	55 mm (2.17 in)
Track load reading	6 kgf to 8.5 kgf (13 lbf to 19 lbf)

11. If load reading is not in accordance with the specification, adjust track tension. Refer to *TRACK TENSION ADJUSTMENT*.

NOTICE Too much tension will result in power loss and excessive stresses on suspension components.

Track Tension Adjustment

1. Remove tether cord cap from engine cut-off switch.
2. Lift rear of vehicle and support it off the ground.

CAUTION Use proper lifting techniques, notably by using the force of your legs. Do not attempt to lift the rear of vehicle if it is above your limits.

3. Loosen the rear axle nut or screws.
4. Tighten or loosen both adjustment screws (equally) to increase or decrease track tension.

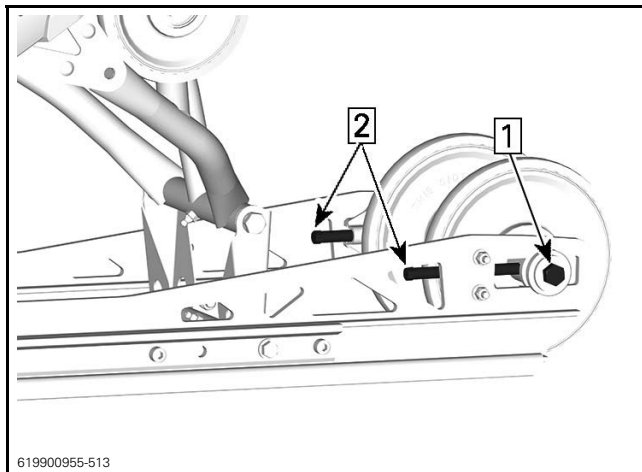

TYPICAL

Step 1: Loosen the axle nut on both sides

Step 2: Tighten or loosen the adjustment screws

5. If correct tension is unattainable, contact an authorized Lynx dealer.
6. Retighten the rear axle nut to specification.

TIGHTENING TORQUE	
Rear idler wheel retaining nut	40 N•m ± 5 N•m (30 lbf•ft ± 4 lbf•ft)

7. Check track alignment as described below.

Track Alignment

WARNING

Before checking track alignment, ensure that the track is free of all particles which could be thrown out while track is rotating. Keep hands, tools, feet and clothing clear of track. Always lift the snowmobile on a wide-base stand with a rear deflector panel. Ensure no one is standing in close proximity to the snowmobile, especially at the rear of the track. Never rotate track at high speed.

Centrifugal force could cause debris, damaged or loose studs, pieces of torn track, or an entire severed track to be violently thrown backwards out of the tunnel with tremendous force.

1. Lift rear of vehicle and support it off the ground.

 CAUTION Use proper lifting techniques, notably by using the force of your legs. Do not attempt to lift the rear of vehicle if it is above your limits.

2. Start engine and accelerate slightly so that track slowly turns. This must be done in a short period of time (15 to 20 seconds).
3. Check that the track is well centered; equal distance on both sides between edges of track guides and slider shoes.

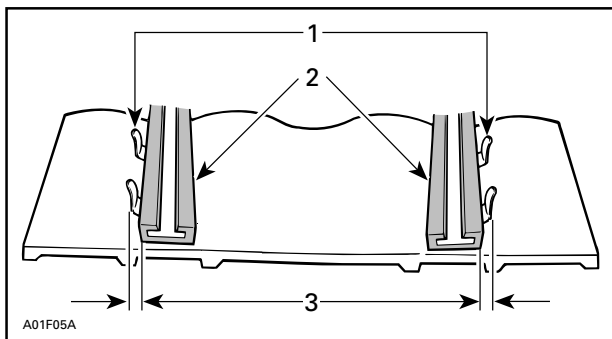

1. Guides
2. Slider shoes
3. Equal distance

4. To correct track alignment:

- 4.1 Stop engine.
- 4.2 Remove tether cord cap from engine cut-off switch.

⚠ WARNING

Remove tether cord cap from engine cut-off switch before performing any maintenance or adjustment, unless otherwise specified. Vehicle must be parked in a safe place, away from the trail.

- 4.3 Loosen the rear axle nut.
- 4.4 Tighten adjustment screw on side where the slider shoe is the farthest from the track insert guides.

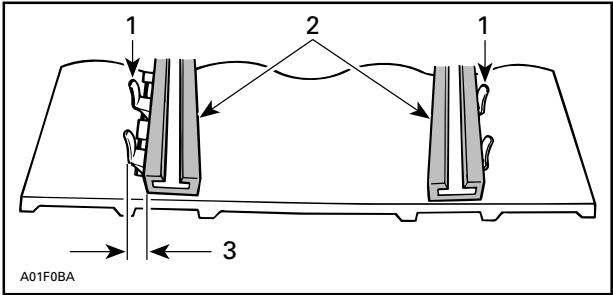

1. Guides
2. Slider shoes
3. Tighten on this side

5. Tighten the rear axle nut.

⚠ WARNING

Properly tighten wheel retaining bolt, otherwise wheel may come off and cause track to "lock".

6. Restart engine and rotate track slowly to recheck alignment.
7. Tighten the rear axle nut to specified torque.

TIGHTENING TORQUE	
Rear axle nut	$48 \text{ N}\cdot\text{m} \pm 6 \text{ N}\cdot\text{m}$ (35 lbf·ft \pm 4 lbf·ft)

8. Reposition snowmobile on the ground.

Suspension

Rear Suspension Condition

Visually inspect all suspension components including slider shoes, springs, wheels, etc.

NOTE: During normal driving, snow will act as a lubricant and coolant for the slider shoes. Extensive riding on ice or sanded snow, will create excessive heat build-up and cause premature slider shoe wear.

Suspension Stopper Strap Condition

Inspect stopper straps for wear and cracks, bolt and nut for tightness. If loose inspect holes for deformation. Replace as required. Tighten nut to specification.

TIGHTENING TORQUE	
Stopper strap nut	10 N•m ± 1 N•m (89 lbf•in ± 9 lbf•in)

Suspension Lubrication

Lubricate the following suspension pivots at grease fittings. Refer to *MAINTENANCE SCHEDULE* for maintenance frequency.

SUSPENSION GREASE	
Scandinavia	SYNTHETIC SUSPENSION GREASE (EUR) (P/N 779226)
All other countries	SYNTHETIC SUSPENSION GREASE (P/N 779163)

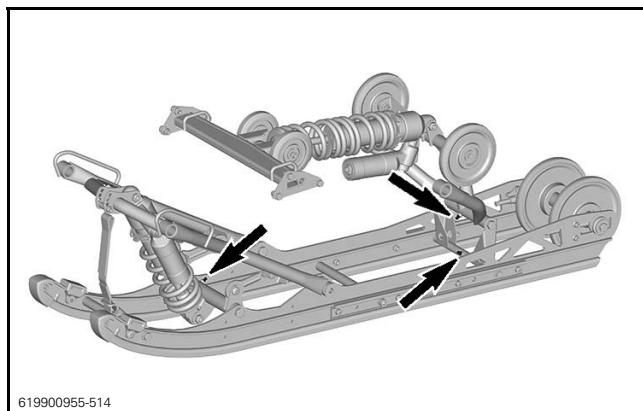

Steering and Front Suspension Condition

Visually inspect steering and front suspension for tightness of components (steering arms, control arms and links, tie rods, ball joints, ski bolts, ski legs, etc.). If necessary, contact an authorized Lynx dealer.

Skis

Wear and Condition of Skis and Runners

Check the condition of the skis and ski runner carbides. If worn, contact an authorized Lynx dealer.

WARNING

Excessively worn skis and/or ski runners will adversely affect snowmobile control.

Fuses

Access to Fuse Block

Open RH side panel, refer to *CONTROLS, INSTRUMENTS AND EQUIPMENT*.

Fuses Location

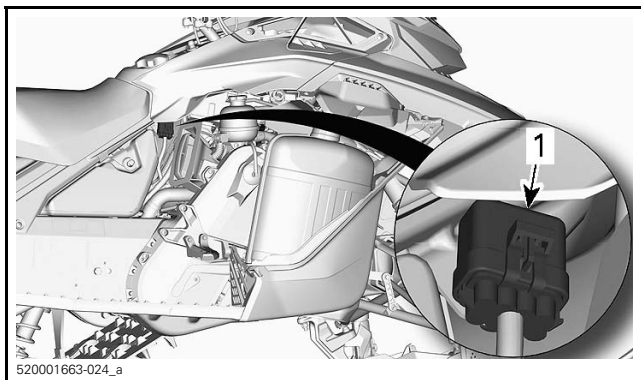

1. Fuse block

Unlock fuse block from its cover.

FUSE IDENTIFICATION	AMPERAGE RATING
Accessories	7.5 A
Loads	25 A

Fuse Inspection

Check fuse condition and replace it if necessary.

To remove fuse from holder, pull fuse out. Check if filament is melted.

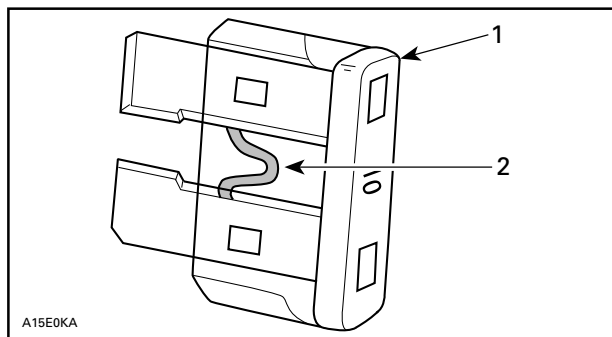

1. Fuse
2. Check if melted

WARNING

Do not use a higher rated fuse.

WARNING

If fuse has burnt out, source of malfunction should be determined and corrected before restarting. See an authorized Lynx dealer for servicing.

VEHICLE CARE

Post-Operation Care

Remove snow and ice from rear suspension, track, front suspension, steering mechanism and skis.

WARNING

Make sure tether cord cap is away from engine cut-off switch before standing in front the vehicle, getting close to the track or rear suspension components.

Always cover your snowmobile when leaving it outside overnight or during extended periods of inactivity. This will protect it from frost and snow as well as help retain its appearance.

Vehicle Cleaning and Protection

Wash snowmobile with water mixed with a mild detergent. Use only microfiber cloths or an equivalent.

NOTICE It is necessary to use microfiber cloths or equivalent on windshield and hood to avoid damaging further surfaces to clean.

To remove grease, oil and grime, use heavy duty cleaner.

NOTICE Do not use Heavy duty cleaner on decals or vinyl.

To remove stubborn dirt from all plastic and vinyl surfaces, use cleaner and degreaser.

SERVICE PRODUCT
BRP HEAVY DUTY CLEANER (P/N 293 110 001)
CLEANER AND DEGREASER PRO C1 (P/N 779262)

NOTICE Never clean plastic parts or hood with strong detergent, degreasing agent, paint thinner, acetone, products containing chlorine, etc.

Wax painted portion of the vehicle for better protection.

NOTE: Apply wax on glossy finish only.

STORAGE

During summer, or when a snowmobile is not in use for more than three months, proper storage is necessary.

STORAGE
Clean the vehicle
Add fuel stabilizer to fuel following the product manufacturer recommendations. Run the engine after adding the product to the fuel
Lubricate engine
Lubricate brake lever pivot
Lubricate rear suspension
Block muffler outlet with rags
Lift rear of vehicle until track is clear of the ground. Do not release track tension

⚠ CAUTION Use appropriate lifting device or have assistance to share lifting stress. If a lifting device is not used, use proper lifting techniques, notably by using the force of your legs. Do not attempt to lift the rear of vehicle if it is above your limits.

NOTICE The snowmobile has to be stored in a cool and dry place and covered with an opaque but ventilated tarpaulin. This will prevent sun rays and grime from affecting plastic components and vehicle finish.

NOTICE Fuel stabilizer should be added prior to engine lubrication to ensure carburetor protection against varnish deposits.

TECHNICAL INFORMATION

VEHICLE IDENTIFICATION

Vehicle Description Decal

Vehicle description decal is located on right hand side of tunnel.

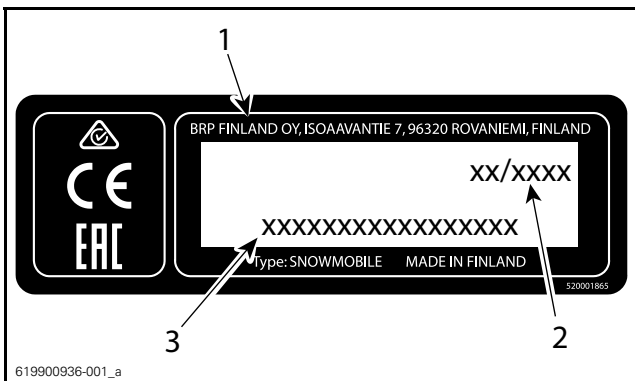
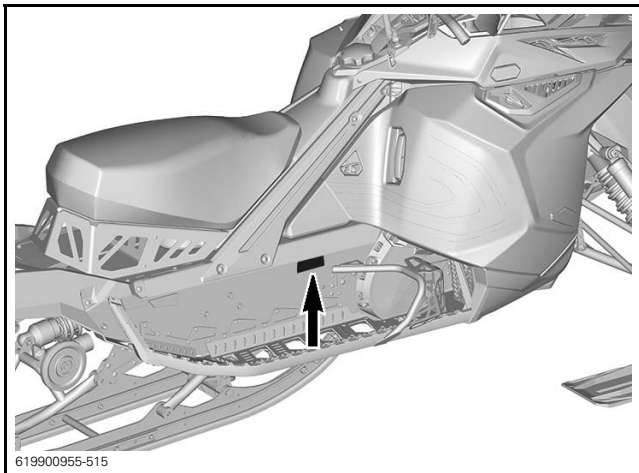

VEHICLE DESCRIPTION DECAL

1. Manufacturer name
2. Manufacturing date
3. Vehicle identification number (VIN)

Identification Numbers

The main components of your snowmobile (engine and frame) are identified by different identification numbers. It may sometimes become necessary to locate these numbers for warranty purposes or to trace your snowmobile in the event of loss. These numbers are required by the authorized Lynx dealer to complete warranty claims properly. We strongly recommend that you take note of all the identification numbers on your snowmobile and supply them to your insurance company.

Vehicle Identification Number (VIN)

VIN is scribed on vehicle description decal. See above. It is also engraved on tunnel near vehicle description decal.

Model number and model year are part of the information found in the VIN. See illustration.

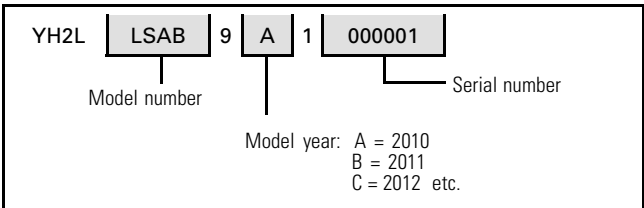

Engine Identification Number Location

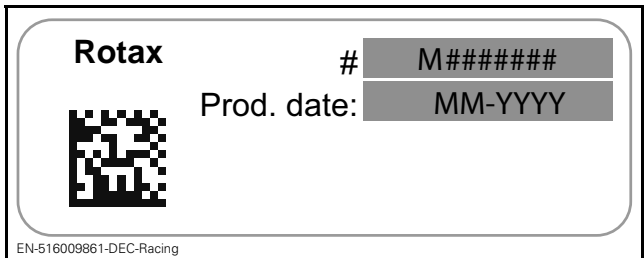

VEHICLE IDENTIFICATION

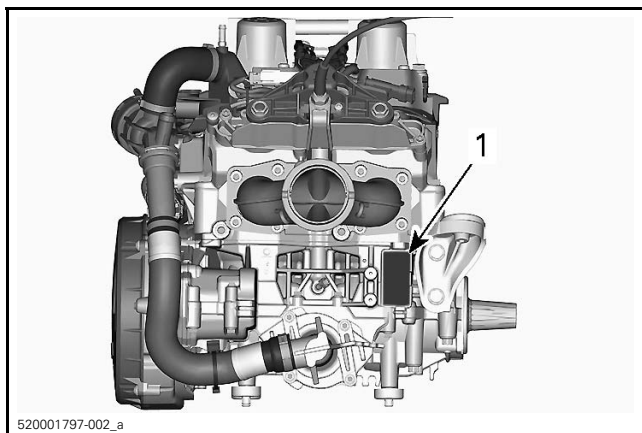

1. Engine identification number

EC DECLARATION OF CONFORMITY

The EC-Declaration of Conformity does not appear in this version of the Operator's Guide.

Please refer to the printed version that was delivered with your vehicle.

***Left blank for Eurasian Conformity
mark where applicable***

SPECIFICATIONS (ENGINE)

ENGINE	
Engine type	Rotax 600RS E-TEC® Liquid cooled with reed valves and electronic RAVE
Number of cylinder	2
Bore	72 mm (2.835 in)
Stroke	73.0 mm (2.874 in)
Displacement	594.4 cm ³ (36.27 in ³)
Maximum power engine speed	8500 ± 100 RPM

FUEL/LUBRICATION SYSTEM	
Fuel delivery	E-TEC direct injection with integrated auxiliary injection system
Idle speed (not adjustable)	1600 ± 200 RPM
Gasoline/oil ratio	33:1
Pre-mix recommended oil	Scandinavia: 2T X2-RS RACING SYNTHETIC OIL (EUR) (P/N 779228) All other countries: (P/N 779229)
Water pump shaft recommended oil	
Water pump shaft oil reservoir capacity	50 ml (1.7 U.S. oz)

SPECIFICATIONS (ENGINE)

ELECTRICAL SYSTEM		
Lighting system output		30 A @ 14.5 V 1340 W @ 6000 RPM
Spark plug	Type	NGK ILKR9Q7G (engine and spark plug threads are indexed)
	Gap	Not adjustable 0.6 mm to 0.7 mm (.024 in to .028 in)

SPECIFICATIONS (VEHICLE)

COOLING SYSTEM		
Coolant	Type	Scandinavia: EXTENDED LIFE PRE-MIXED COOLANT (EUR) (P/N 779223) All other countries: EXTENDED LIFE PRE-MIXED COOLANT (P/N 779150) or coolant specifically formulated for aluminum engines
	Quantity	6 L (6.34 qt (U.S. liq.))

FUEL SYSTEM			
Fuel pump		In-tank electrical fuel pump	
Fuel	Type	Premium unleaded gasoline (fuel which may contain up to 10% MAX ethanol)	
	Octane rating	Inside North America	93 Pump Posted AKI (R+M)/2
		Outside North America	98 (RON)
Fuel tank capacity		18 L (4.8 U.S. gal.)	

SPECIFICATIONS (VEHICLE)

ELECTRICAL SYSTEM	
Taillight and stoplight	2.6 W / 139m W LED
Fuses	Refer to <i>FUSES</i> in <i>MAINTENANCE</i>

DRIVE SYSTEM		
Chaincase oil	Type	Scandinavia: SYNTHETIC CHAINCASE OIL (EUR) (P/N 779185) All other countries: SYNTHETIC CHAINCASE OIL (P/N 779156)
	Capacity	350 ml (12 U.S. oz)
Chaincase ratio		23/51
Drive pulley	Type	Racing pDrive
	Engagement RPM	5300 ± 100 RPM
Driven pulley	Type	Team Rapid reaction
Drive sprocket number of teeth		8

DRIVE SYSTEM		
Track	Width	38 cm (15 in)
	Length	348.7 cm (137 in)
	Profile height	44.5 mm (1.75 in)
Track adjustment	Deflection	48 N•m ± 6 N•m (35 lbf•ft ± 4 lbf•ft)
	Force	6.0 kgf to 8.5 kgf (13 lbf to 19 lbf)

BRAKE SYSTEM		
Brake	Type	Single 220 mm stainless floating disc with 4 pistons caliper
Brake fluid	Type	DOT 4
	Quantity	50 ml (1.69 U.S. oz)
Caliper		Fixed 4 pistons (4 x 30 mm)
Brake pad material		Metallic
Minimum brake pad thickness		0.5 mm (.02 in)
Minimum brake disc thickness		5.4 mm (.213 in)
Maximum brake disc warpage		0.2 mm (.01 in)

FRONT SUSPENSION	
Suspension type	A-LFS RS
Suspension maximum travel	272 mm (10.7 in)
Shock absorber type	KYB 40 HCLR Kashima Coated

SPECIFICATIONS (VEHICLE)

REAR SUSPENSION		
Suspension type		PPS2 3500R
Suspension maximum travel Measured at rear arm		390 mm (15.4 in)
Shock absorber type	Center	KYB 46 HCLR Kashima Coated
	Rear	KYB 46 HCLR Kashima Coated
WEIGHT AND DIMENSIONS		
Mass (dry)		219 kg (482.8 lb)
Overall length		3 170 mm (124.8 in)
Overall width		1 280 mm (50.4 in)
Overall height		1 190 mm (46.9 in)
Ski stance		1 092 mm \pm 21 mm (43 in \pm .8 in)

TROUBLE- SHOOTING

TROUBLESHOOTING GUIDELINES

ENGINE IS CRANKED BUT FAILS TO START

1. No fuel to the engine.

- *Check fuel tank level, add fuel if necessary.*

2. System voltage too low.

- *Contact an authorized Lynx dealer.*

ENGINE LACKS ACCELERATION OR POWER

1. Engine warm-up in progress.

- *Drive vehicle at low speeds for a few minutes.*

2. Engine break-in period not completed.

- *Complete break-in period.*

3. Drive and driven pulleys require servicing.

- *Contact an authorized Lynx dealer.*

4. Engine overheats.

- *Check coolant level, see MAINTENANCE PROCEDURES.*
- *Check heat exchangers cleanliness. Clean if necessary.*

5. Drive belt worn too thin.

- *If the drive belt has lost more than 3 mm (1/8 in) of its original width, it will affect vehicle performance.*
- *Replace drive belt.*

6. Incorrect track adjustment.

- *See MAINTENANCE PROCEDURES and/or an authorized Lynx dealer for proper alignment and tension adjustments.*

7. R.A.V.E. valves problem.

- *Seek service from an authorized Lynx dealer, repair shop, or person of your own choosing for maintenance, repair, or replacement.*

8. Fuel pressure too low.

- *Seek service from an authorized Lynx dealer, repair shop, or person of your own choosing for maintenance, repair, or replacement.*

ENGINE BACKFIRES

1. Engine is running too hot.

- *See item 4 of ENGINE LACKS POWER.*

ENGINE BACKFIRES (cont'd)

2. Ignition timing is incorrect or there is an ignition system failure.

- *Seek service from an authorized Lynx dealer, repair shop, or person of your own choosing for maintenance, repair, or replacement.*

3. Exhaust system leak.

- *Seek service from an authorized Lynx dealer, repair shop, or person of your own choosing for maintenance, repair, or replacement.*

4. Fuel pressure too low.

- *Seek service from an authorized Lynx dealer, repair shop, or person of your own choosing for maintenance, repair, or replacement.*

ENGINE MISFIRES

1. Water in fuel.

- *Drain fuel system and refill with fresh fuel.*

2. RAVE valves malfunction.

- *Have RAVE valves system inspected. Seek service from an authorized Lynx dealer, repair shop, or person of your own choosing for maintenance, repair, or replacement.*

HEATED GRIPS/THUMB WARMERS ARE NOT WORKING

1. Engine RPM is too low.

- *Make sure engine RPM is above 2000.*

ENGINE HAS SHUT DOWN

1. The engine shuts down after long periods of idling.

- *Do not let engine idle too long. Refer to VEHICLE WARM-UP in OPERATING INSTRUCTION.*

WATER PUMP SHAFT OIL LEVEL LOWERS

1. External leak.

- *Replace leaking part.*

2. Engine internal leak.

- *Have the engine bottom end repaired .*

MONITORING SYSTEM

Icons, Messages and Beeper Codes

The gauge icons inform you of an anomaly or a particular condition.

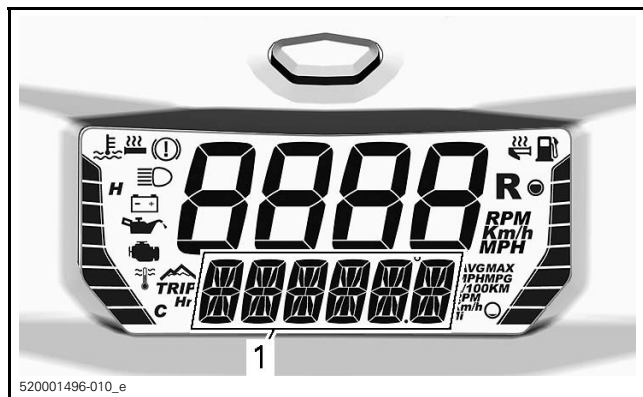

Icons can come on or blink alone or in combination with others.





1. Lower display

In addition to the icons, messages are displayed along with a beep code.

See following table for details.

ICON ON	BEEPER	MESSAGE	DESCRIPTION
	4 short beeps every 30 seconds	ENGINE OVERHEAT	Engine is overheating, reduce snowmobile speed and run in loose snow or stop engine immediately and let engine cool down. Check coolant level, refer to <i>MAINTENANCE</i> . If coolant level is correct and overheating persists, contact an authorized Lynx dealer. Do not run the engine if condition persists.
		MUFFLER	Reduce speed or stop engine. Let engine cool down and restart. If overheating persists, contact an authorized Lynx dealer. Do not run the engine if condition persists.
		ECM	
	Short beeps repeating rapidly	OVERHEAT In combination with "ENGINE OVERHEAT" above	Critical overheating. Stop engine immediately and let engine cool down. Check coolant level, refer to <i>MAINTENANCE</i> . If coolant level is correct and overheating persists, contact an authorized Lynx dealer. Do not run the engine if condition persists.
		OVERHEAT In combination with "MUFFLER" OR "ECM"	Critical overheating. Stop engine immediately and let engine cool down. If overheating persists, contact an authorized Lynx dealer. Do not run the engine if condition persists.

MONITORING SYSTEM

ICON ON	BEEPER	MESSAGE	DESCRIPTION
	4 short beeps	CHECK ENGINE	Engine fault, see an authorized Lynx dealer, repair shop or person of your own choosing as soon as possible.
 (blinking)	4 short beeps		Displayed when brake is applied for more than 15 seconds while throttle lever is squeezed and vehicle is moving at more than 5 km/h (3 MPH).
—	4 short beeps every 8 seconds	KNOCK	Engine detonation (RPM is limited when this condition occurs). <ul style="list-style-type: none"> – Ensure recommended fuel is used. – Check fuel quality, replace if necessary. – If fault still occurs, contact an authorized Lynx dealer, repair shop, or person of your own choosing.
—	4 short beeps every 5 minutes	REV LIMIT	Engine RPM limited for protection when certain faults occur.

ICON ON	BEEPER	MESSAGE	DESCRIPTION
—	—	OVER REV	Indicates that maximum engine RPM is reached. Check clutch calibration.
—	Short beeps repeating rapidly	SHUT DOWN	Shutdown procedure in force due to engine overheating or fuel pump problem.
—	—	COMMUNICATION	Communication problem between ECM and gauge. Stop engine, remove tether cord cap. Wait a few minutes, then start engine. If problem persists, contact an authorized Lynx dealer.

Fault Codes

If the check engine icon is ON, it is possible to read fault code(s) on the gauge.

To read active fault code(s), select the vehicle speed and engine RPM display combination, see *MULTIFUNCTION DIGITAL GAUGE*.

NOTE: Make sure to select actual vehicle speed and actual engine RPM (not "top" or "average" values).

Press and hold the gauge mode button and simultaneously switch from HIGH to LOW beam repeatedly several times until a code is displayed.

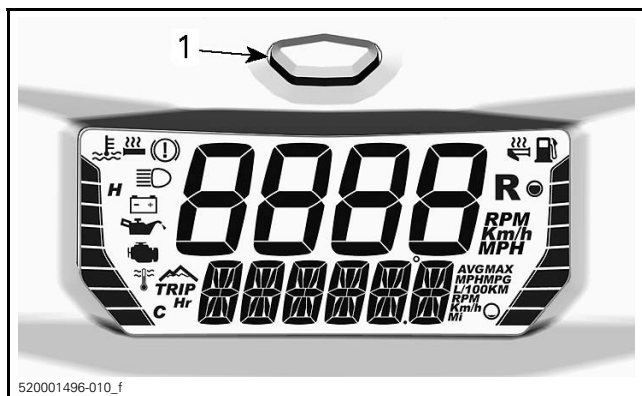

1. Gauge mode button

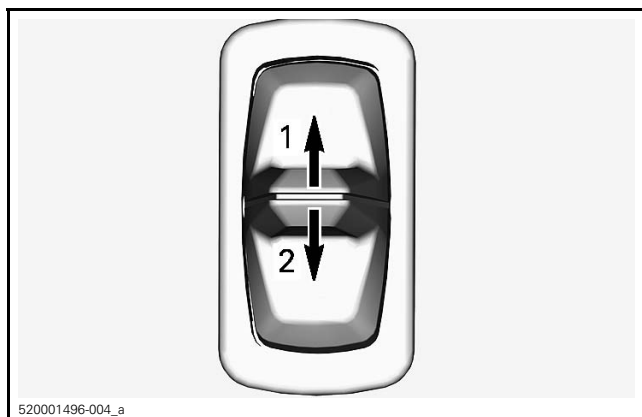

1. High beam
2. Low beam

If two or more codes are registered, use the gauge mode button to scroll.

To exit the fault codes mode, press and hold the gauge mode button.

Contact an authorized Lynx dealer for code signification.

WARRANTY

BRP FINLAND OY INTERNATIONAL LIMITED WARRANTY: 2020 LYNX® SNOWMOBILES

1) SCOPE OF THE LIMITED WARRANTY

Bombardier Recreational Products Inc. ("BRP")* warrants its 2020 LYNX snowmobiles sold by distributors or dealers authorized by BRP to distribute LYNX snowmobiles ("LYNX Distributor/Dealer") outside of the fifty United States, Canada, members of the European Economic Area (which is comprised of the member states of the European Union plus Norway, Iceland and Liechtenstein) ("EEA"), members states of the Commonwealth of the Independent States (including Ukraine and Turkmenistan) ("CIS") and Turkey, from defects in material or workmanship for the period and under the conditions described below.

Non-factory installed parts and accessories are not covered under this limited warranty. Please refer to the applicable parts and accessories limited warranty text.

This limited warranty will become null and void if: (1) the snowmobile was used for racing or any other competitive activity, at any point, even by a previous owner; or (2) the snowmobile has been altered or modified in such a way so as to adversely affect its operation, performance or durability, or has been altered or modified to change its intended use.

2) LIMITATIONS OF LIABILITY

TO THE EXTENT PERMITTED BY LAW, THIS WARRANTY IS EXPRESSLY GIVEN AND ACCEPTED IN LIEU OF ANY AND ALL OTHER WARRANTIES, EXPRESSED OR IMPLIED, INCLUDING WITHOUT LIMITATION ANY WARRANTY OF MERCHANTABILITY OR FITNESS FOR A PARTICULAR PURPOSE. TO THE EXTENT THAT THEY CANNOT BE DISCLAIMED, THE IMPLIED WARRANTIES ARE LIMITED IN DURATION TO THE LIFE OF THE EXPRESS WARRANTY. INCIDENTAL AND CONSEQUENTIAL DAMAGES ARE EXCLUDED FROM COVERAGE UNDER THIS WARRANTY. SOME JURISDICTIONS DO NOT ALLOW FOR THE DISCLAIMERS, LIMITATIONS AND EXCLUSIONS IDENTIFIED ABOVE, AS A RESULT, THEY MAY NOT APPLY TO YOU. THIS WARRANTY GIVES YOU SPECIFIC RIGHTS, AND YOU MAY ALSO HAVE OTHER LEGAL RIGHTS WHICH MAY VARY FROM COUNTRY TO COUNTRY. (FOR PRODUCTS PURCHASED IN AUSTRALIA SEE CLAUSE 4 BELOW).

Neither the LYNX Distributor/Dealer nor any other person has been authorized to make any affirmation, representation or warranty regarding the product, other than those contained in this limited warranty, and if made, shall not be enforceable against BRP.

BRP reserves the right to modify this warranty at any time, being understood that such modification will not alter the warranty conditions applicable to the products sold while this warranty is in effect.

3) EXCLUSIONS – ARE NOT WARRANTED

The following are not warranted under this limited warranty under any circumstances:

- Normal wear and tear;
- Routine maintenance items, tune ups, adjustments;
- Damage caused by negligence or failure to provide proper maintenance and/or storage, as described in the Operator's Guide;
- Damage resulting from removal of parts, improper repairs, service, maintenance, modifications or use of parts or accessories not manufactured or approved by BRP which in its reasonable judgement are either incompatible with the product or adversely affect its operation, performance and durability, or resulting from repairs done by a person that is not an authorized servicing LYNX Distributor/Dealer;
- Damage caused by abuse, abnormal use, neglect, racing or operation of the product on surfaces other than snow, or operation of the product in a manner inconsistent with the recommended operation described in the Operator's Guide;
- Damage resulting from accident, submersion, fire, snow or water ingestion, theft, vandalism or any act of God;
- Operation with fuels, oils or lubricants which are not suitable for use with the product (see the Operator's Guide);
- Damage resulting from rust, corrosion or exposure to the elements;
- Incidental or consequential damages, or damages of any kind including without limitation towing, storage, transportation expenses, telephone, rental, taxi, inconvenience, insurance coverage, loan payments, loss of time, loss of income; or time missed for downtime experience due to service work.
- And damage resulting from studs installed on tracks if the installation does not conform to BRP's instructions.

4) WARRANTY COVERAGE PERIOD

This warranty will be in effect from (1) the date of delivery to the first retail consumer or (2) the date the product is first put into use, whichever occurs first and for a period of:

TWELVE (12) CONSECUTIVE MONTHS, for private or commercial use owners. However, the warranty coverage period on a snowmobile delivered between June 1st and December 1st of a given year will expire November 30th of the following year.

The repair or replacement of parts or the performance of service under this warranty does not extend the life of this warranty beyond its original expiration date.

Note that the duration and any other modalities of the warranty coverage are subject to the applicable national or local legislation in the customer's country.

FOR PRODUCTS SOLD IN AUSTRALIA ONLY

Nothing in these Warranty terms and conditions should be taken to exclude, restrict or modify the application of any condition, warranty, guarantee, right or remedy conferred or implied under the Competition and Consumer Act 2010 (Cth), including the Australian Consumer Law or any other law, where to do so would contravene that law, or cause any part of these terms and conditions to be void. The benefits given to you under this limited warranty are in addition to other rights and remedies that you have under Australian law.

Our goods come with guarantees that cannot be excluded under the Australian Consumer Law. You are entitled to a replacement or refund for a major failure and for compensation for any other reasonably foreseeable loss or damage. You are also entitled to have the goods repaired or replaced if the goods fail to be of acceptable quality and the failure does not amount to a major failure.

5) CONDITIONS TO HAVE WARRANTY COVERAGE

This warranty coverage is available **only** if each of the following conditions has been fulfilled:

- The 2020 LYNX snowmobile must be purchased as new and unused by its first owner from a LYNX Distributor/Dealer authorized to distribute LYNX snowmobiles in the country in which the sale occurred;

- The BRP specified pre-delivery inspection process must be completed and documented;
- The product must have undergone proper registration by an authorized LYNX Distributor/Dealer;
- The 2020 LYNX snowmobile must be purchased in the country or union of countries in which the purchaser resides.
- Routine maintenance outlined in the Operator's Guide must be timely performed in order to maintain warranty coverage. BRP reserves the right to make warranty coverage contingent upon proof of proper maintenance.

BRP will not honour this limited warranty to any private use owner or commercial use owner if one of the preceding conditions has not been met. Such limitations are necessary in order to allow BRP to preserve both the safety of its products, and also that of its consumers and the general public.

6) WHAT TO DO TO OBTAIN WARRANTY COVERAGE

The customer must cease using the snowmobile upon the appearance of an anomaly. The customer must notify a servicing LYNX Distributor/Dealer within two (2) days of the appearance of a defect, and provide it with reasonable access to the product and reasonable opportunity to repair it. The customer must also present to the authorized LYNX Distributor/Dealer, proof of purchase of the product and must sign the repair/work order prior to starting the repair in order to validate the warranty repair. All parts replaced under this limited warranty become the property of BRP.

Note that the notification period is subject to the applicable national or local legislation in customer's country.

7) WHAT BRP WILL DO

To the extent permitted by law, BRP's obligations under this warranty are limited to, at its sole discretion, repairing parts found defective under normal use, maintenance and service, or replacing such parts with new genuine LYNX parts without charge for parts and labour, at any authorized LYNX Distributor/Dealer during the warranty coverage period under the conditions described herein. BRP's responsibility is limited to making the required repairs or replacements of parts.

No claim of breach of warranty shall be cause for cancellation or rescission of the sale of the snowmobile to the owner. You may have other legal rights which may vary from country to country.

In the event that service is required outside of the country of original sale, the owner will bear responsibility for any additional charges due to local practices and conditions, such as, but not limited to, freight, insurance, taxes, license fees, import duties, and any and all other financial charges, including those levied by governments, states, territories and their respective agencies.

BRP reserves the right to improve or modify products from time to time without assuming any obligation to modify products previously manufactured.

8) TRANSFER

If the ownership of a product is transferred during the warranty coverage period, this limited warranty, subject to its terms and conditions, shall also be transferred and be valid for the remaining coverage period provided BRP or an authorized LYNX Distributor/Dealer receives a proof that the former owner agreed to the transfer of ownership, in addition to the co-ordinates of the new owner.

9) CONSUMER ASSISTANCE

In the event of a controversy or a dispute in connection with this limited warranty, BRP suggests that you try to resolve the issue at the LYNX Distributor/Dealer level. We recommend discussing the issue with the authorized LYNX Distributor/Dealer's service manager or owner.

If the matter still remains unresolved, contact BRP by filling out the customer contact form at www.brp.com or contact BRP by mail at one of the addresses listed under the *CONTACT US* section of this guide.

* For the territory covered by this limited warranty, products are distributed and serviced by Bombardier Recreational Products Inc. or its affiliates.

© 2019 Bombardier Recreational Products Inc. All rights reserved.

® Registered trademark of Bombardier Recreational Products Inc. and its affiliates.

BRP FINLAND OY LIMITED WARRANTY FOR THE EUROPEAN AND THE COMMONWEALTH OF THE INDEPENDENT STATES (CIS) AREAS AND TURKEY : 2020 LYNX® SNOWMOBILES

1) SCOPE OF THE LIMITED WARRANTY

Bombardier Recreational Products Inc. ("BRP")* warrants its 2020 LYNX snowmobiles sold by distributors or dealers authorized by BRP to distribute LYNX snowmobiles ("LYNX Distributor/Dealer") in member states of the European Economic Area (which is comprised of the member states of the European Union plus Norway, Iceland and Liechtenstein) ("EEA"), in member states of the Commonwealth of the Independent States (including Ukraine and Turkmenistan) ("CIS") and Turkey from defects in material or workmanship for the period and under the conditions described below.

Non-factory installed parts and accessories are not covered under this limited warranty. Please refer to the applicable parts and accessories limited warranty text.

This limited warranty will become null and void if: (1) the snowmobile was used for racing or any other competitive activity, at any point, even by a previous owner; or (2) the snowmobile has been altered or modified in such a way so as to adversely affect its operation, performance or durability, or has been altered or modified to change its intended use.

2) LIMITATIONS OF LIABILITY

TO THE EXTENT PERMITTED BY LAW, THIS WARRANTY IS EXPRESSLY GIVEN AND ACCEPTED IN LIEU OF ANY AND ALL OTHER WARRANTIES, EXPRESSED OR IMPLIED, INCLUDING WITHOUT LIMITATION ANY WARRANTY OF MERCHANTABILITY OR FITNESS FOR A PARTICULAR PURPOSE. TO THE EXTENT THAT THEY CANNOT BE DISCLAIMED, THE IMPLIED WARRANTIES ARE LIMITED IN DURATION TO THE LIFE OF THE EXPRESS WARRANTIES. INCIDENTAL AND CONSEQUENTIAL DAMAGES ARE EXCLUDED FROM COVERAGE UNDER THIS WARRANTY. SOME JURISDICTIONS DO NOT ALLOW FOR THE DISCLAIMERS, LIMITATIONS AND EXCLUSIONS IDENTIFIED ABOVE, AS A RESULT, THEY MAY NOT APPLY TO YOU. THIS WARRANTY GIVES YOU SPECIFIC RIGHTS, AND YOU MAY ALSO HAVE OTHER LEGAL RIGHTS WHICH MAY VARY FROM COUNTRY TO COUNTRY.

Neither the LYNX Distributor/Dealer nor any other person has been authorized to make any affirmation, representation or warranty regarding the product, other than those contained in this limited warranty, and if made, shall not be enforceable against BRP.

BRP reserves the right to modify this warranty at any time, being understood that such modification will not alter the warranty conditions applicable to the products sold while this warranty is in effect.

3) EXCLUSIONS – ARE NOT WARRANTED

The following are not warranted under this limited warranty under any circumstances:

- Normal wear and tear;
- Routine maintenance items, tune ups, adjustments;
- Damage caused by negligence or failure to provide proper maintenance and/or storage, as described in the Operator's Guide;
- Damage resulting from removal of parts, improper repairs, service, maintenance, modifications or use of parts or accessories not manufactured or approved by BRP which in its reasonable judgement are either incompatible with the product or adversely affect its operation, performance and durability, or resulting from repairs done by a person that is not an authorized servicing LYNX Distributor/Dealer;
- Damage caused by abuse, abnormal use, neglect, racing or operation of the product on surfaces other than snow, or operation of the product in a manner inconsistent with the recommended operation described in the Operator's Guide;
- Damage resulting from accident, submersion, fire, snow or water ingestion, theft, vandalism or any act of God;
- Operation with fuels, oils or lubricants which are not suitable for use with the product (see the Operator's Guide);
- Damage resulting from rust, corrosion or exposure to the elements;
- Incidental or consequential damages, or damages of any kind including without limitation towing, transportation expenses, storage, telephone, rental, taxi, inconvenience, insurance coverage, loan payments, loss of time, loss of income or time missed for downtime experience due to service work;
- and damage resulting from studs installed on tracks if the installation does not conform to BRP's instructions.

4) WARRANTY COVERAGE PERIOD

This warranty will be in effect from (1) the date of delivery to the first retail consumer or (2) the date the product is first put into use, whichever occurs first and for a period of:

TWENTY-FOUR (24) CONSECUTIVE MONTHS, for private use owners and TWELVE (12) CONSECUTIVE MONTHS for commercial use owners. However, the warranty coverage period on a snowmobile delivered between June 1st and December 1st of a given year will expire November 30th of the applicable year. A snowmobile is used commercially when it is used in connection with generating income or any work or employment during any part of the warranty period. A snowmobile is also used commercially when, at any point during the warranty period, it has commercial tags or is licensed for commercial use.

The repair or replacement of parts or the performance of service under this warranty does not extend the life of this warranty beyond its original expiration date.

Note that the duration and any other modalities of the warranty coverage are subject to the applicable national or local legislation in the customer's country.

5) CONDITIONS TO HAVE WARRANTY COVERAGE

This warranty coverage is available **only** if each of the following conditions has been fulfilled:

- The 2020 LYNX snowmobile must be purchased as new and unused by its first owner from a LYNX Distributor/Dealer authorized to distribute LYNX products in the country in which the sale occurred;
- The BRP specified pre-delivery inspection process must be completed and documented;
- The product must have undergone proper registration by an authorized LYNX Distributor/Dealer;
- The 2020 LYNX snowmobile must be purchased within the EEA by an EEA resident, in the CIS for residents of the countries comprised in such area and in Turkey for residents of Turkey; and
- Routine maintenance outlined in the Operator's Guide must be timely performed in order to maintain warranty coverage. BRP reserves the right to make warranty coverage contingent upon proof of proper maintenance.

BRP will not honour this limited warranty to any private use owner or commercial use owner if one of the preceding conditions has not been met. Such limitations are necessary in order to allow BRP to preserve both the safety of its products, and also that of its consumers and the general public.

6) WHAT TO DO TO OBTAIN WARRANTY COVERAGE

The customer must cease using the snowmobile upon the appearance of an anomaly. The customer must notify a servicing LYNX Distributor/Dealer within two (2) months of the appearance of a defect, and provide it with reasonable access to the product and reasonable opportunity to repair it. The customer must also present to the authorized LYNX Distributor/Dealer, proof of purchase of the product and must sign the repair/work order prior to starting the repair in order to validate the warranty repair. All parts replaced under this limited warranty become the property of BRP.

Note that the notification period is subject to the applicable national or local legislation in customer's country.

7) WHAT BRP WILL DO

To the extent permitted by law, BRP's obligations under this warranty are limited to, at its sole discretion, repairing parts found defective under normal use, maintenance and service, or replacing such parts with new genuine LYNX parts without charge for parts and labour, at any authorized LYNX Distributor/Dealer during the warranty coverage period under the conditions described herein. BRP's responsibility is limited to making the required repairs or replacements of parts. No claim of breach of warranty shall be cause for cancellation or rescission of the sale of the snowmobile to the owner. You may have other legal rights which may vary from country to country.

In the event that service is required outside of the EEA, CIS or Turkey, the owner will bear responsibility for any additional charges due to local practices and conditions, such as, but not limited to, freight, insurance, taxes, license fees, import duties, and any and all other financial charges, including those levied by governments, states, territories and their respective agencies.

BRP reserves the right to improve or modify products from time to time without assuming any obligation to modify products previously manufactured.

8) TRANSFER

If the ownership of a product is transferred during the warranty coverage period, this limited warranty, subject to its terms and conditions, shall also be transferred and be valid for the remaining coverage period provided BRP or an authorized LYNX Distributor/Dealer receives a proof that the former owner agreed to the transfer of ownership, in addition to the co-ordinates of the new owner.

9) CONSUMER ASSISTANCE

In the event of a controversy or a dispute in connection with this limited warranty, BRP suggests that you try to resolve the issue at the LYNX Distributor/Dealer level. We recommend discussing the issue with the authorized LYNX Distributor/Dealer's service manager or owner.

If the matter still remains unresolved, contact BRP by filling out the customer contact form at www.brp.com or contact BRP by mail at one of the addresses listed under the *CONTACT US* section of this guide.

* In the EEA, products are distributed and serviced by BRP European Distribution S.A. and other affiliates or subsidiaries of BRP.

© 2019 Bombardier Recreational Products Inc. All rights reserved.

® Registered trademark of Bombardier Recreational Products Inc. and its affiliates.

ADDITIONAL TERMS AND CONDITIONS FOR FRANCE ONLY

The following terms and conditions are applicable to products sold in France only:

The seller shall deliver goods that are complying with the contract and shall be responsible for defects existing upon delivery. The seller shall also be responsible for defects resulting from packaging, assembling instructions or the installation when it is its responsibility per the contract or if accomplished under its responsibility. To be compliant with the contract, the good shall:

1. Be fit for normal use for goods similar thereto and, if applicable:
 - Correspond to the description provided by the seller and have the qualities presented to the buyer though sample or model;
 - Have the qualities that a buyer may legitimately expect considering the public declarations of the seller, the manufacturer of its representative, including in advertising or labeling; or
2. Have the characteristics mutually agreed upon as between the parties or be fit for the specific use intended by the buyer and brought to the attention of the seller and which accepted

The action for failure to comply is prescribed after two years after delivery of the goods. The seller is responsible for the warranty for hidden defects of the good sold if such hidden defects are rendering the good unfit for the intended use, or if they diminish its use in such a way that the buyer would not have acquired the good or would have given a lesser price, had he known. The action for such hidden defects shall be taken by the buyer within 2 years of the discovery of the defect.

MAINTENANCE RECORDS

Send photocopy of maintenance record to BRP if needed.

PREDELIVERY	
Serial number: _____ Mileage / km: _____ Hours: _____ Date: _____ Dealer no: _____ Notes: _____	Signature/Print: _____
Refer to vehicle Pre-Delivery Bulletin for detailed installation procedures	

FIRST INSPECTION	
Mileage / km: _____ Hours: _____ Date: _____ Dealer no: _____ Notes: _____	Signature/Print: _____
For maintenance schedule refer to Maintenance Information section of this operator's guide	

SERVICE

Mileage /
km:

Hours:

Date:

Dealer
no:

Notes:

Signature/Print:

For maintenance schedule refer to Maintenance Information
section of this operator's guide

SERVICE

Mileage /
km:

Hours:

Date:

Dealer
no:

Notes:

Signature/Print:

For maintenance schedule refer to Maintenance Information
section of this operator's guide

SERVICE

Mileage /
km:

Hours:

Date:

Dealer
no:

Notes:

Signature/Print:

For maintenance schedule refer to Maintenance Information
section of this operator's guide

SERVICE

Mileage /
km:

Hours:

Date:

Dealer
no:

Notes:

Signature/Print:

For maintenance schedule refer to Maintenance Information
section of this operator's guide

SERVICE

Mileage /
km:

Hours:

Date:

Dealer
no:

Notes:

Signature/Print:

For maintenance schedule refer to Maintenance Information
section of this operator's guide

SERVICE

Mileage /
km:

Hours:

Date:

Dealer
no:

Notes:

Signature/Print:

For maintenance schedule refer to Maintenance Information
section of this operator's guide

SERVICE

Mileage /
km:

Hours:

Date:

Dealer
no:

Notes:

Signature/Print:

For maintenance schedule refer to Maintenance Information
section of this operator's guide

SERVICE

Mileage /
km:

Hours:

Date:

Dealer
no:

Notes:

Signature/Print:

For maintenance schedule refer to Maintenance Information
section of this operator's guide

SERVICE

Mileage /
km:

Hours:

Date:

Dealer
no:

Notes:

Signature/Print:

For maintenance schedule refer to Maintenance Information
section of this operator's guide

SERVICE

Mileage /
km:

Hours:

Date:

Dealer
no:

Notes:

Signature/Print:

For maintenance schedule refer to Maintenance Information
section of this operator's guide

CUSTOMER INFORMATION

CONTACT US

www.brp.com

Asia

Room 4609, Tower 2,
Grand Gateway 3 Hong Qiao
Road Shanghai,
China 200020

21F Shinagawa East One Tower
2-16-1 Konan, Minatoku-ku,
Tokyo 108-0075
Japan

Europe

Skaldenstraat 125
B-9042 Gent
Belgium

Itterpark 11
D-40724 Hilden
Germany

ARTEPARC Bâtiment B
Route de la côte d'Azur, Le Canet
13590 Meyreuil
France

Ingvald Ystgaardsvei 15
N-7484 Trondheim
Norway

Isoaavantie 7
PL 8040
96101 Rovaniemi

Spinnvägen 15
903 61 Umeå
Sweden

Avenue d'Ouchy 4-6
1006 Lausanne
Switzerland

North America

565 de la Montagne Street
Valcourt (Québec) J0E 2L0
Canada

Sa De Cv, Av. Ferrocarril 202
Parque Ind. Querétaro, Lote2-B
76220
Santa Rosa Jáuregui, Qro., Mexico

Sturtevant, Wisconsin, U.S.A.
10101 Science Drive
Sturtevant, Wisconsin
53177
U.S.A.

Oceania

6 Lord Street
Lakes Business Park
Botany, NSW 2019
Australia

3B Echelon Place, East Tamaki,
Auckland 2013,
New Zealand

South America

Rua James Clerck Maxwell, 230
TechnoPark Campinas SP 13069-380
Brazil

CHANGE OF ADDRESS/OWNERSHIP

If your address has changed or if you are the new owner of the snowmobile, be sure to notify BRP by either:

- Notifying an authorized Lynx dealer.
- Mailing one of the change of address cards on the following pages at one of the BRP addresses indicated in the *CONTACT US* section of this guide.

In case of change of ownership, please join a proof that the former owner agreed to the transfer.

Notifying BRP, even after the expiration of the limited warranty, is very important as it enables BRP to reach the snowmobile owner if necessary, like when safety recalls are initiated. It is the owner's responsibility to notify BRP.

STOLEN UNITS: If your personal snowmobile is stolen, you should notify BRP or an authorized Lynx dealer. We will ask you to provide your name, address, phone number, the vehicle identification number and the date it was stolen.

CHANGE OF ADDRESS/OWNERSHIP

CHANGE OF ADDRESS <input type="checkbox"/>	CHANGE OF OWNERSHIP <input type="checkbox"/>		
VEHICLE IDENTIFICATION NUMBER			
Model Number	Vehicle Identification Number (V.I.N.)		
OLD ADDRESS OR PREVIOUS OWNER:	_____ NAME		
	NO.	STREET	APT
	CITY	STATE/PROVINCE	ZIP/POSTAL CODE
	COUNTRY		TELEPHONE
NEW ADDRESS OR NEW OWNER:	_____ NAME		
	NO.	STREET	APT
	CITY	STATE/PROVINCE	ZIP/POSTAL CODE
	COUNTRY		TELEPHONE
	E-MAIL ADDRESS		

Iv00A2F

CHANGE OF ADDRESS <input type="checkbox"/>	CHANGE OF OWNERSHIP <input type="checkbox"/>		
VEHICLE IDENTIFICATION NUMBER			
Model Number	Vehicle Identification Number (V.I.N.)		
OLD ADDRESS OR PREVIOUS OWNER:	_____ NAME		
	NO.	STREET	APT
	CITY	STATE/PROVINCE	ZIP/POSTAL CODE
	COUNTRY		TELEPHONE
NEW ADDRESS OR NEW OWNER:	_____ NAME		
	NO.	STREET	APT
	CITY	STATE/PROVINCE	ZIP/POSTAL CODE
	COUNTRY		TELEPHONE
	E-MAIL ADDRESS		

Iv00A2F

***This page is
intentionally blank***

CHANGE OF ADDRESS/OWNERSHIP

<input type="checkbox"/> CHANGE OF ADDRESS		<input type="checkbox"/> CHANGE OF OWNERSHIP	
VEHICLE IDENTIFICATION NUMBER			
Model Number	Vehicle Identification Number (V.I.N.)		
OLD ADDRESS OR PREVIOUS OWNER:		NAME	
		NO.	STREET APT
		CITY	STATE/PROVINCE ZIP/POSTAL CODE
		COUNTRY	TELEPHONE
NEW ADDRESS OR NEW OWNER:		NAME	
		NO.	STREET APT
		CITY	STATE/PROVINCE ZIP/POSTAL CODE
		COUNTRY	TELEPHONE
		E-MAIL ADDRESS	

Iv00A2F

<input type="checkbox"/> CHANGE OF ADDRESS		<input type="checkbox"/> CHANGE OF OWNERSHIP	
VEHICLE IDENTIFICATION NUMBER			
Model Number	Vehicle Identification Number (V.I.N.)		
OLD ADDRESS OR PREVIOUS OWNER:		NAME	
		NO.	STREET APT
		CITY	STATE/PROVINCE ZIP/POSTAL CODE
		COUNTRY	TELEPHONE
NEW ADDRESS OR NEW OWNER:		NAME	
		NO.	STREET APT
		CITY	STATE/PROVINCE ZIP/POSTAL CODE
		COUNTRY	TELEPHONE
		E-MAIL ADDRESS	

Iv00A2F

***This page is
intentionally blank***

VEHICLE MODEL No. _____

VEHICLE IDENTIFICATION NUMBER (V.I.N.) _____

ENGINE IDENTIFICATION NUMBER (E.I.N.) _____

Owner: _____
NAME

No. STREET APT

CITY STATE/PROVINCE ZIP/POSTAL CODE

Purchase Date _____
YEAR MONTH DAY

Warranty Expiry Date _____
YEAR MONTH DAY

To be completed by the dealer at the time of the sale.

DEALER IMPRINT AREA

⚠ WARNING

THIS OPERATOR'S GUIDE IS WRITTEN USING A GENERIC FORM AND FOR A GENERAL USE OF THE SNOWMOBILE. THE **RADIEN 600RS** RACE MODEL IS DESIGNED EXCLUSIVELY FOR COMPETITION IN A CLOSED COURSE AND CANNOT BE USE WHERE ELSE THAN A RACING ENVIRONMENT DUE TO ITS DESIGN.

THIS SNOWMOBILE IS INTENDED TO BE EXCLUSIVELY USED IN COMPETITIONS AND IS EXCLUDED FROM SCOPE OF REGULATION (EU) 2016/1628 PER ITS ARTICLE 2, PARAGRAPH 2. (K).

THIS VEHICLE INCLUDING THE ENGINE IS CLASSIFIED AS A COMPETITION SNOWMOBILE AND SHOULD NEVER BE USED ON PUBLIC TRAILS.



ski-doo LYNX SEA-DOO EVINRUDE ROTAX Can-am

®™ AND THE BRP LOGO ARE TRADEMARKS OF BOMBARDIER RECREATIONAL PRODUCTS INC. OR ITS AFFILIATES.
©2019 BOMBARDIER RECREATIONAL PRODUCTS INC. ALL RIGHTS RESERVED. PRINTED IN CANADA.

619 900 973
OPERATOR'S GUIDE RAVE RS Series / ENGLISH
GUIDE DU CONDUCTEUR RAVE RS Series / ANGLAIS
FAIT AU / MADE IN CANADA U/M.P.C.